

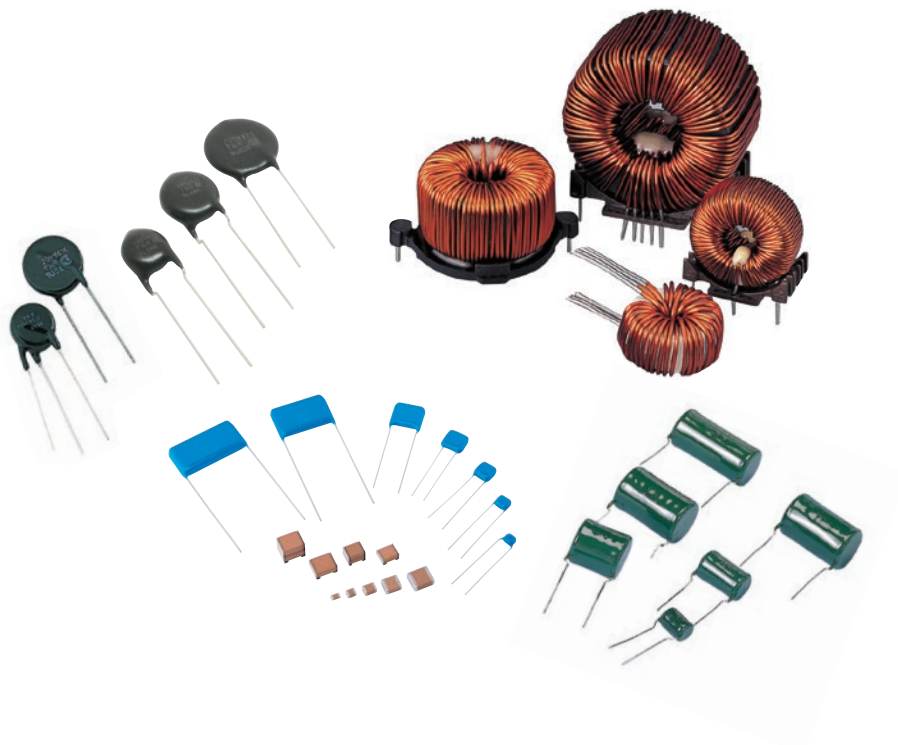

2021

CERAMIC CAPACITORS
VARISTORS
FILM CAPACITORS
CHOKE COILS

CAT.NO.E1002A / E1006D / E1003X / E1008V



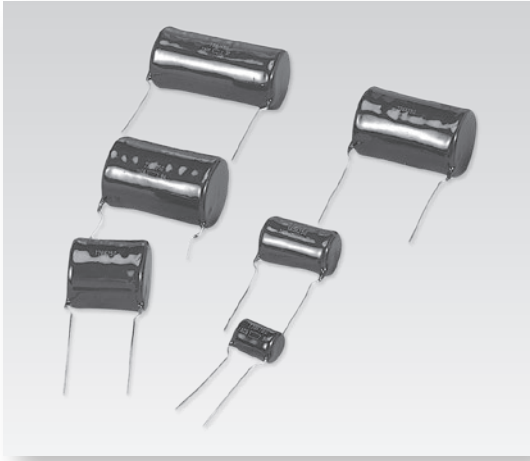

FILM CAPACITORS

Production Guide	P110-115
Series Table	P110
Part Numbering System	P111
Minimum Packaging Quantity	P112
Precautions and Guidelines	P114
Product Specifications	P116-130
TACE Series	P116
TACD Series	P117
TACC Series	P120
TACB Series	P121
HACE Series	P124
HACD Series	P125
HACB Series	P128

Series	Major uses	Rated voltage range	Rated Capacitance range (μF)	Category temperature range (°C)	Page
TACE	High frequency use, metallized polypropylene film. Permissible large current and anti-vibration	250 to 1000 V_{dc}	0.47 to 22	-40 to +105	116
TACD	High frequency use, metallized polypropylene film. Standard type (Downsizing of TACB series)	250 to 1000 V_{dc}	0.033 to 22	-40 to +105	117
TACC	High frequency use, metallized polypropylene film. Large capacitance type of TACB series	450 to 1000 V_{dc}	1.0 to 18	-40 to +105	120
TACB	High frequency use, metallized polypropylene film.	250 to 800 V_{dc}	0.033 to 22	-40 to +105	121
HACE	High frequency use, metallized polypropylene film. High voltage type and anti-vibration	630 to 2000 V_{dc}	0.18 to 1.5	-40 to +105	124
HACD	High frequency use, metallized polypropylene film. High voltage type of TACD series (Downsizing of HACB series)	630 to 4000 V_{dc}	0.0033 to 1.5	-40 to +105	125
HACB	High frequency use, metallized polypropylene film. High voltage type of TACB series	630 to 4000 V_{dc}	0.001 to 1.2	-40 to +105	128

◆Metallized polypropylene film capacitors

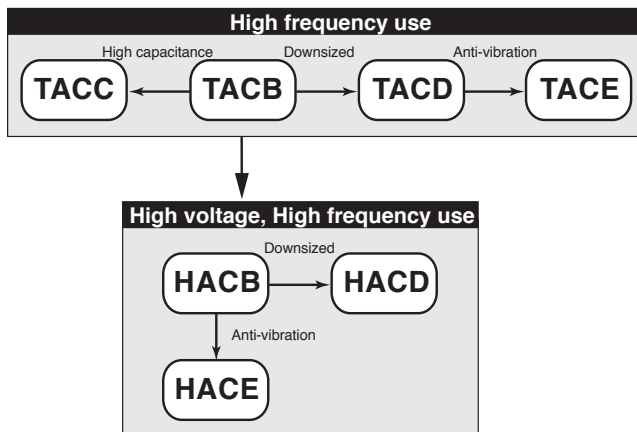

Part Numbering System

(Example:TACD series 250V 0.82μF)

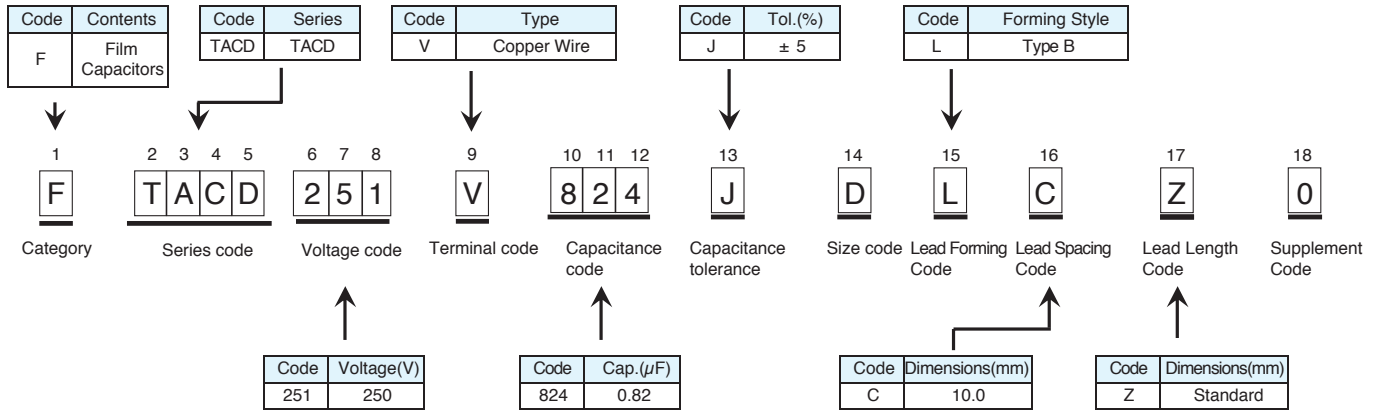

*Others (Refer to the standard ratings .)

(Series code)

Code	Series name
TACE	TACE
TACD	TACD
TACC	TACC
TACB	TACB
HACE	HACE

Code	Series name
HACD	HACD
HACB	HACB

(Size code)

This is eigenvalue. The details are standard ratings.

(Lead Forming Code)

Code	Type
A	Straight lead
F	Type A
L	Type B

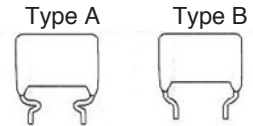

(Voltage code)

Code	Voltage(V)
251	250
3B1	315
401	400
501	500
631	630

Code	Voltage(V)
801	800
102	1000
1C2	1250
152	1500
162	1600

Code	Voltage(V)
182	1800
202	2000
252	2500
3B2	3150
402	4000

(Lead Spacing Code)

Code	Dimensions(mm)
B	7.5
C	10.0
G	12.5
D	15.0
O	16.5
H	17.5
N	20.0
1	21.5
E	22.5

コード	Dimensions(mm)
P	25.0
2	26.5
F	27.5
Q	30.0
J	37.5
4	41.5
W	47.5
5	51.5

(Terminal code)

Code	Terminal
V	Tin plated copper wire
U	Tin plated copper clad steel wire
N	4 terminals tab

(Capacitance code)

Unit of capacitance with (pF),and a sign of capacitance expresses it in 3 characters.
significant digit(two columns) + index(one column) unit : pF
(Example :1μF[1,000,000pF]="105")

(Capacitance tolerance code)

Code	tolerance(%)
H	±3
J	±5
K	±10

(Lead Length Code)

Code	Dimensions(mm)
M	5.0
S	Special
Z	Standard

(Supplement Code)

This is eigenvalue. The details are standard ratings.

Minimum Packaging Quantity

Please order by units of minimum packaging quantity.

◆Metallized polypropylene film capacitors

Series	Voltage (V _{dc})	Rated Capacitance (μF)	Bagged (pcs/box)	Boxed (pcs)	Series	Voltage (V _{dc})	Rated Capacitance (μF)	Bagged (pcs/box)	Boxed (pcs)
TACE	250	15 to 18	-	200	TACC	450	5.6 to 8.2	200	-
		22	-	150			10 to 12	150	-
	400	6.8 to 8.2	-	200			15	100	-
		10 to 12	-	150			18	100	-
	630	0.47 to 3.3	-	200		3.3	200	-	
		4.7	-	150		3.9 to 6.8	150	-	
	1000	0.47 to 1.0	-	200		8.2	100	-	
		1.5	-	150		10	100	-	
TACD	250	0.82 to 1.2	600	-		800	2.2 to 2.7	200	-
		1.5 to 1.8	500	-			3.3 to 3.9	150	-
		2.2	400	-			4.7	100	-
		2.7	300	-			5.6 to 6.8	100	-
		3.3 to 3.9	500	-			1.0	200	-
		4.7	400	-			1.2	150	-
		5.6 to 8.2	300	-			1.5 to 1.8	100	-
		10 to 12	200	-			2.2 to 2.7	100	-
		15	150	-	0.33 to 0.39		800	-	
		315	0.33 to 0.68	800	-		0.47 to 0.68	600	-
	0.82		600	-	0.82 to 1.2	500	-		
	1.0 to 1.8		500	-	1.5 to 1.8	400	-		
	2.2 to 2.7		300	-	2.2 to 2.7	300	-		
	3.3		500	-	3.3	400	-		
	3.9		400	-	3.9 to 6.8	300	-		
	4.7		300	-	8.2	200	-		
	5.6		200	-	10	200	-		
	6.8 to 8.2		200	-	12	150	-		
	10 to 12		150	-	15 to 22	100	-		
	400	0.22 to 0.27	800	-	0.22 to 0.27	800	-		
		0.33 to 0.68	600	-	0.33 to 0.47	600	-		
		0.82 to 1.0	400	-	0.56 to 2.2	400	-		
		1.2 to 1.5	300	-	2.7 to 3.9	300	-		
		1.8 to 2.7	400	-	4.7 to 5.6	200	-		
		3.3 to 3.9	300	-	6.8	200	-		
		4.7	200	-	8.2	150	-		
		5.6 to 6.8	200	-	0.1	700	-		
		8.2	150	-	0.12 to 0.18	600	-		
		500	0.22 to 0.27	800	-	0.22 to 0.33	500	-	
	0.33 to 0.68		500	-	0.39 to 1.2	400	-		
	0.82		300	-	1.5 to 1.8	300	-		
	1.0		400	-	2.2	200	-		
	1.2		500	-	2.7	200	-		
	1.5 to 1.8		400	-	3.3 to 3.9	150	-		
	2.2 to 2.7		300	-	4.7 to 5.6	100	-		
	3.3 to 3.9		200	-	0.056 to 0.082	800	-		
	4.7		150	-	0.1 to 0.12	600	-		
	630		0.1 to 0.15	800	-	0.15	500	-	
		0.18	600	-	0.18 to 0.27	400	-		
		0.22 to 0.33	500	-	0.33 to 0.47	300	-		
		0.39	400	-	0.56 to 0.68	400	-		
		0.47	300	-	0.82 to 1.0	300	-		
		0.56 to 1.0	400	-	1.2 to 1.8	200	-		
		1.2 to 1.5	300	-	2.2	150	-		
		1.8	200	-	2.7 to 3.9	100	-		
		2.2 to 2.7	200	-	0.033 to 0.039	800	-		
		3.3	150	-	0.047 to 0.082	600	-		
	800	3.9 to 5.6	100	-	0.082 to 0.15	400	-		
		0.056 to 0.082	800	-	0.18 to 0.22	300	-		
		0.1 to 0.12	600	-	0.27 to 0.33	400	-		
		0.15 to 0.27	500	-	0.39 to 0.56	300	-		
		0.33 to 0.68	400	-	0.68 to 1.0	200	-		
		0.82 to 1.0	300	-	1.2	150	-		
		1.2 to 1.8	200	-	TACB	250	0.33 to 0.39	800	-
		2.2	150	-			0.47 to 0.68	600	-
		2.7 to 3.9	100	-			0.82 to 1.2	500	-
		0.033 to 0.039	800	-			1.5 to 1.8	400	-
	0.047 to 0.082	600	-	2.2 to 2.7			300	-	
	0.1 to 0.12	500	-	3.3			400	-	
	0.15 to 0.18	400	-	3.9 to 6.8			300	-	
	0.22 to 0.27	300	-	8.2			200	-	
	0.33 to 0.39	400	-	10			200	-	
	0.47 to 0.68	300	-	12			150	-	
	0.82 to 1.0	200	-	15 to 22	100	-			
	1.2	150	-	0.22 to 0.27	800	-			
	1000	0.033 to 0.039	800	-	0.33 to 0.47	600	-		
		0.047 to 0.082	600	-	0.56 to 2.2	400	-		
		0.1 to 0.12	500	-	2.7 to 3.9	300	-		
		0.15 to 0.18	400	-	4.7 to 5.6	200	-		
		0.22 to 0.27	300	-	6.8	200	-		
		0.33 to 0.39	400	-	8.2	150	-		
		0.47 to 0.68	300	-	0.1	700	-		
		0.82 to 1.0	200	-	0.12 to 0.18	600	-		
		1.2	150	-	0.22 to 0.33	500	-		
					0.39 to 1.2	400	-		
				1.5 to 1.8	300	-			
				2.2	200	-			
				2.7	200	-			
				3.3 to 3.9	150	-			
				4.7 to 5.6	100	-			
				0.056 to 0.082	800	-			
				0.1 to 0.12	600	-			
				0.15	500	-			
				0.18 to 0.27	400	-			
				0.33 to 0.47	300	-			
				0.56 to 0.68	400	-			
				0.82 to 1.0	300	-			
				1.2 to 1.8	200	-			
				2.2	150	-			
				2.7 to 3.9	100	-			
				0.033 to 0.039	800	-			
				0.047 to 0.082	600	-			
				0.082 to 0.15	400	-			
				0.18 to 0.22	300	-			
				0.27 to 0.33	400	-			
				0.39 to 0.56	300	-			
				0.68 to 1.0	200	-			
				1.2	150	-			

Series	Voltage (V _{dc})	Rated Capacitance (μF)	Bagged (pcs/box)	Boxed (pcs)	Series	Voltage (V _{dc})	Rated Capacitance (μF)	Bagged (pcs/box)	Boxed (pcs)
HACE	630	0.47 to 1.0	-	200	HACB	630	0.033 to 0.039	800	-
		1.5	-	150			0.047 to 0.068	600	-
	1250	0.47 to 0.68	-	150			0.082	500	-
		1.0 to 1.5	-	100			0.10 to 0.18	400	-
		1600	0.27 to 0.33	-			150	0.22 to 0.27	300
2000	0.18 to 0.22	-	150	0.33 to 0.39			400	-	
HACD	630	0.047 to 0.082	600	-			0.47 to 0.56	300	-
		0.1	500	-			0.68 to 0.82	200	-
		0.12 to 0.22	400	-			0.1 to 0.12	150	-
		0.27	300	-			0.018	800	-
		0.33	500	-		0.022 to 0.033	600	-	
		0.39 to 0.68	400	-		0.039 to 0.056	500	-	
		0.82	300	-		0.068 to 0.1	400	-	
		1.0 to 1.2	200	-		0.12	300	-	
		1.5	200	-		0.15	500	-	
		1000	0.033 to 0.056	600	-	0.18 to 0.27	400	-	
	0.068		500	-	0.33	300	-		
	0.082 to 0.1		400	-	0.39 to 0.56	200	-		
	0.12 to 0.47		300	-	0.68	150	-		
	0.56 to 0.82		200	-	0.82 to 1.2	100	-		
	1.0		200	-	0.012 to 0.027	600	-		
	1.2		150	-	0.033	500	-		
	1250		0.018 to 0.039	600	-	0.039 to 0.056	400	-	
			0.047 to 0.082	400	-	0.068 to 0.082	300	-	
			0.1 to 0.12	300	-	0.1 to 0.12	400	-	
		0.15 to 0.18	400	-	0.15 to 0.18	300	-		
		0.22 to 0.27	300	-	0.22 to 0.33	200	-		
		0.33 to 0.47	200	-	0.39 to 0.56	150	-		
		0.56 to 0.68	150	-	0.68 to 0.82	100	-		
		0.82 to 1.2	100	-	1.0	100	-		
		1600	0.0068 to 0.012	600	-	0.0047 to 0.0068	600	-	
			0.015	500	-	0.0082 to 0.012	500	-	
	0.018 to 0.027		400	-	0.015	400	-		
	0.033 to 0.068		300	-	0.018 to 0.033	300	-		
	0.082 to 0.15		400	-	0.039	500	-		
	0.18 to 0.22		200	-	0.047 to 0.082	400	-		
	0.27		200	-	0.1 to 0.12	300	-		
	0.33		150	-	0.15 to 0.18	200	-		
	2000		0.0033 to 0.0056	600	-	0.22 to 0.27	150	-	
			0.0068	500	-	0.33 to 0.47	100	-	
		0.008 to 0.015	400	-	0.001 to 0.0039	800	-		
		0.018 to 0.022	300	-	0.0047 to 0.0056	600	-		
		0.027 to 0.068	400	-	0.0068	500	-		
		0.082	300	-	0.0082 to 0.012	400	-		
		0.1 to 0.15	200	-	0.015 to 0.022	300	-		
		0.18	150	-	0.027 to 0.047	400	-		
		0.220 to 0.330	100	-	0.056	300	-		
		0.330 to 0.470	100	-	0.068 to 0.082	200	-		
	2500	0.015 to 0.022	300	-	0.1	200	-		
		0.027 to 0.033	200	-	0.12 to 0.15	150	-		
		0.039 to 0.056	300	-	0.18 to 0.27	100	-		
		0.068 to 0.082	200	-	0.0047 to 0.0068	200	-		
		0.1	150	-	0.0082	400	-		
	3150	0.0068 to 0.01	300	-	0.010 to 0.012	300	-		
		0.012 to 0.015	200	-	0.015	200	-		
		0.018 to 0.027	300	-	0.018	200	-		
		0.033 to 0.039	200	-	0.022 to 0.033	150	-		
	4000	0.047	150	-	0.0027	300	-		
		0.0039 to 0.0056	300	-	0.0033 to 0.0047	200	-		
		0.0068 to 0.01	200	-	0.0056 to 0.0068	300	-		
		0.012 to 0.015	300	-	0.0082 to 0.01	200	-		
		0.018	200	-	0.012 to 0.018	150	-		

The circuits described as examples in this catalog and the "delivery specifications" are featured in order to show the operations and usage of our products, however, this fact does not guarantee that the circuits are available to function in your equipment systems.

We are not in any case responsible for any failures or damage caused by the use of information contained herein.

You should examine our products, of which the characteristics are described in the "delivery specifications" and other documents, and determine whether or not our products suit your requirements according to the specifications of your equipment systems. Therefore, you bear final responsibility regarding the use of our products.

Please make sure that you take appropriate safety measures such as use of redundant design and malfunction prevention measures in order to prevent fatal accidents and/or fires in the event any of our products malfunction.

1 In designing device circuits

- (1) Confirming operating and installation environment, use capacitors within the performance limits prescribed in their catalog or product specifications.
- (2) Do not use capacitors at the environment of which temperature drastically changes even though it stays within the prescribed range.
- (3) Do not use capacitors at the humid or dewy environment.
- (4) Select the proper capacitors matching for an application.
- (5) Do not use the capacitors, which have particularly been designed for a specific application, into other applications. In particular, do not use the capacitor samples, which are provided for the purpose of appearance or electrical check, for other purpose.
- (6) Charge and discharge cycles that are rapidly repeated at more than the prescribed conditions causes capacitors to deteriorate in their characteristics or breakdown.
- (7) Unless otherwise prescribed, do not apply the surge or ripple voltage of which peak voltage exceeds the specified full rated voltage.
- (8) Where using capacitors at a rated temperature, do not apply voltage more than the derating voltage specified at the temperature.
- (9) Where using capacitors into AC or pulsing circuits, do not apply current more than the specified maximum permissible current. For the details, consult us.
- (10) A rise in capacitor temperature, which is caused by a ripple current, shall be so set as not to exceed the specified limit at non-circulating air condition. Note that a capacitor changes in the temperature rise by the operating temperature as its capacitance changes.
- (11) The sum of ambient temperature, including the influence of heat from other components, and the rise of temperature by self-heating must be within the specified upper category.
- (12) Do not connect capacitors in series or parallel. Consult us for it.

2 Installation and assembly board washing

- (1) Do not pull or twist the lead wires of a capacitor by applying the force more than the limits when installing the capacitor into the printed circuit board. In particular, the capacitor shall be so installed into the board as not to have a crack in the covering resin of the capacitor. If it cannot be avoided, use capacitors with pre-formed lead wires.

- (2) If a large-sized capacitor is installed and/or the device is exposed to a vibration shock, anchor the body of the capacitor to the board by means of a clamp or adhesive that does not effect the capacitor.
- (3) Do not touch the exterior cover of a capacitor to the metal part of the device or other components.
- (4) For soldering, follow the specified conditions. Because the plastic film of the capacitors is effected by heat, overheating the capacitors during soldering causes $\tan\delta$ to increase.
- (5) If the assembly boards are washed for the purposes of removing residual flux, follow the specified conditions.
 - ①Alcohols, Water soluble solvents.
 - ②Cleaning Methods Vaporized Cleaning, Dip Cleaning, Ultrasonic Cleaning. When Cleaning, Temperature and Period Shall not Be Exceeded 50°C and 5 Minutes.
 - ③After Treatment It is Necessary To Remove Cleaning Solvent From P.W.B. By enough Dryness.

3 While devices are operating

- (1) Do not touch a capacitor, while under load, directly with bare hands. Touching the capacitor causes a shock hazard.
- (2) Even under non-load condition, a capacitor may have charge. Also, the capacitor that has been discharged may be spontaneously recharged by dielectric absorption. Handle the capacitor after discharging with a discharge resistor.
- (3) Do not short the terminals of a capacitor by applying any conductive object. Do not spill any electric-conductive liquid such as acid or alkaline solution over the capacitor as Well.
- (4) Do not use capacitors at the following environment ;
 - ①Water, chemicals or oil spatters on the capacitors.
 - ②Direct sunlight pours down onto the capacitors.
 - ③Ozone, ultraviolet rays or radiation is applied to the capacitors.
 - ④Corrosive gas is exposed to the capacitors.

4 If a capacitor should fail while under load, follow the below

If smoke, fire or stench should be emitted while the device is operating, turn off or unplug the power supply of the device and then extinguish a fire.

5 Storage and handling

- (1) For the capacitors that are stored for more than a year, make sure of their characteristics and lead solder ability before use.
- (2) Don't increase an excessive vibration, a shock, pressure, and so on to the capacitors.
- (3) Don't add the excessive power to the lead wire.
- (4) Scratching the dielectric film of a capacitor causes If a capacitor body is scratched or damaged so deep that the dielectric film is damaged, the dielectric will be destructively damaged. Handle capacitors with care.

6 Disposal

Burning capacitors may discharge toxic gas. Ask a specialist for the disposal of industrial wastes.

7 Catalogs

Product specifications in this catalog are subject to change without notice.

Please request and make sure our product specifications before purchase and/or use.

8 Response to the Substances of Concern

- (1) Nippon Chemi-Con aims for developing products that meet laws and regulations concerning substances of concern.
(Some products may contain regulated substances for exempted application.)
Please contact us for more information about law-compliance status.
- (2) According to the content of REACH handbook (Guidance on requirements for substances in articles which is published on May 2008), our electronic components are "articles without any intended release". Therefore they are not applicable for "Registration" for EU REACH Regulation Article 7 (1).
Reference: Electrolytic Condenser Investigation Society
"Study of REACH Regulation in EU about Electrolytic Capacitor"
(publicized on 13 March 2008)

TACE Series



- Maximum operating temperature 105°C.
- Allowable temperature rise 15K max.
- Tab : 4 terminals

◆ SPECIFICATIONS

Items	Characteristics										
Category temperature range	-40 to +105°C										
Rated voltage range	250V _{dc} , 400V _{dc} , 630V _{dc} , 1000V _{dc}										
Capacitance tolerance	±5% (J)										
Voltage proof (Terminal - Terminal)	No degradation, at 150% of rated voltage shall be applied for 60 seconds.										
Dissipation factor (tanδ)	Not more than 0.05% : Equal or less than 1μF. Not more than (c×0.015+0.05)% : More than 1μF.										
Insulation resistance (Terminal - Terminal)	No less than 30000MΩ : Equal or less than 0.33μF. No less than 10000ΩF : More than 0.33μF.										
	<table border="1"> <tr> <td>Rated voltage (V_{dc})</td> <td>250</td> <td>400</td> <td>630</td> <td>1000</td> </tr> <tr> <td>Measurement voltage (V_{dc})</td> <td>100</td> <td>100</td> <td>500</td> <td>500</td> </tr> </table>	Rated voltage (V _{dc})	250	400	630	1000	Measurement voltage (V _{dc})	100	100	500	500
Rated voltage (V _{dc})	250	400	630	1000							
Measurement voltage (V _{dc})	100	100	500	500							
Endurance	The following specifications shall be satisfied, after 1000hrs with applying rated voltage×125% at 105°C.										
	<table border="1"> <tr> <td>Appearance</td> <td>No serious degradation</td> </tr> <tr> <td>Insulation resistance (Terminal - Terminal)</td> <td>No less than 10000MΩ : Equal or less than 0.33μF. No less than 3000ΩF : More than 0.33μF.</td> </tr> <tr> <td>Dissipation factor (tanδ)</td> <td>No more than initial specification at 1kHz.</td> </tr> <tr> <td>Capacitance change</td> <td>Within ±5% of initial value.</td> </tr> </table>	Appearance	No serious degradation	Insulation resistance (Terminal - Terminal)	No less than 10000MΩ : Equal or less than 0.33μF. No less than 3000ΩF : More than 0.33μF.	Dissipation factor (tanδ)	No more than initial specification at 1kHz.	Capacitance change	Within ±5% of initial value.		
Appearance	No serious degradation										
Insulation resistance (Terminal - Terminal)	No less than 10000MΩ : Equal or less than 0.33μF. No less than 3000ΩF : More than 0.33μF.										
Dissipation factor (tanδ)	No more than initial specification at 1kHz.										
Capacitance change	Within ±5% of initial value.										
Loading under damp heat	The following specifications shall be satisfied, after 500hrs with applying rated voltage at 40°C90~95%RH.										
	<table border="1"> <tr> <td>Appearance</td> <td>No serious degradation.</td> </tr> <tr> <td>Insulation resistance (Terminal - Terminal)</td> <td>No less than 10000MΩ : Equal or less than 0.33μF. No less than 3000ΩF : More than 0.33μF.</td> </tr> <tr> <td>Dissipation factor (tanδ)</td> <td>No more than initial specification at 1kHz.</td> </tr> <tr> <td>Capacitance change</td> <td>Within ±5% of initial value.</td> </tr> </table>	Appearance	No serious degradation.	Insulation resistance (Terminal - Terminal)	No less than 10000MΩ : Equal or less than 0.33μF. No less than 3000ΩF : More than 0.33μF.	Dissipation factor (tanδ)	No more than initial specification at 1kHz.	Capacitance change	Within ±5% of initial value.		
Appearance	No serious degradation.										
Insulation resistance (Terminal - Terminal)	No less than 10000MΩ : Equal or less than 0.33μF. No less than 3000ΩF : More than 0.33μF.										
Dissipation factor (tanδ)	No more than initial specification at 1kHz.										
Capacitance change	Within ±5% of initial value.										

◆ STANDARD RATINGS

WV (V _{dc})	Cap (μF)	Dimensions (mm)				Maximum ripple current (Arms)	WV (Vac)	Part Number
		W	H	T	P			
250	15	24.5	30.0	28.6	22.5	14.3	100	FTACE251N156JEAES0
	18		32.8	31.2		15.6		FTACE251N186JEAES0
	22	29.5	31.9	30.4	27.5	14.2		FTACE251N226JFAFS0
400	6.8	24.5	29.0	27.6	22.5	11.9	150	FTACE401N685JEAES0
	8.2		31.6	30.1		13.1		FTACE401N825JEAES0
	10	29.5	30.9	29.4	27.5	11.8		FTACE401N106JFAFS0
	12		33.6	32.0		13.0		FTACE401N126JFAFS0
630	0.47	17.5	16.5	15.7	15.0	5.9	175	FTACE631N474JDADS0
	0.68		19.3	18.4		7.1		FTACE631N684JDADS0
	1.0		23.0	22.0		8.6		FTACE631N105JDADS0
	1.5	19.5	25.5	24.3	17.5	9.2		FTACE631N155JHAHS0
	2.2	24.5	25.7	24.5		8.6		FTACE631N226JEAES0
	3.3		31.0	29.5		10.6		FTACE631N335JEAES0
4.7	29.5	32.4	30.8	27.5	10.4	FTACE631N475JFAFS0		
1000	0.47	19.5	24.0	22.9	17.5	6.9	250	FTACE102N474JHAHS0
	0.68		28.5	27.1		7.3		FTACE102N684JHAHS0
	1.0	24.5	28.3	27.0	22.5	7.1		FTACE102N105JEAES0
	1.5	29.5	30.1	28.7	27.5	7.3		FTACE102N155JFAFS0

(1)The maximum ripple current : +85°C max., 100kHz, sine wave

(2)WV(Vac) : 50Hz or 60Hz, sine wave

◆ DIMENSIONS

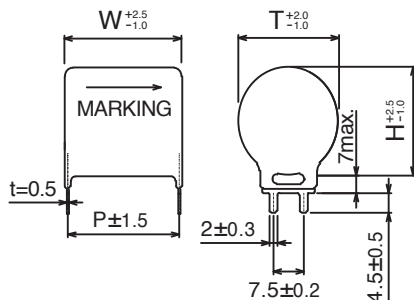

The recommended conditions for mounting.

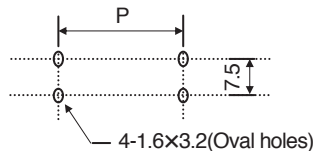

TACD Series



- Maximum operating temperature 105°C.
- Allowable temperature rise 15K max.
- Downsizing of TACB series.

◆SPECIFICATIONS

Items	Characteristics							
Category temperature range	-40 to +105°C							
Rated voltage range	250 to 1000V _{dc}							
Capacitance tolerance	±5% (J)							
Voltage proof (Terminal - Terminal)	No degradation, at 150% of rated voltage shall be applied for 60 seconds.							
Dissipation factor (tanδ)	Not more than 0.05% : Equal or less than 1μF. Not more than (c×0.015+0.05)% : More than 1μF.							
Insulation resistance (Terminal - Terminal)	No less than 30000MΩ : Equal or less than 0.33μF. No less than 10000ΩF : More than 0.33μF.							
	Rated voltage (V _{dc})	250	315	400	500	630	800	1000
	Measurement voltage (V _{dc})	100	100	100	100	500	500	500
Endurance	The following specifications shall be satisfied, after 1000hrs with applying rated voltage×125% at 105°C.							
	Appearance	No serious degradation						
	Insulation resistance (Terminal - Terminal)	No less than 10000MΩ : Equal or less than 0.33μF.						
		No less than 3000ΩF : More than 0.33μF.						
	Dissipation factor (tanδ)	No more than initial specification at 1kHz.						
Capacitance change	Within ±5% of initial value.							
Loading under damp heat	The following specifications shall be satisfied, after 500hrs with applying rated voltage at 40°C 90~95%RH.							
	Appearance	No serious degradation.						
	Insulation resistance (Terminal - Terminal)	No less than 10000MΩ : Equal or less than 0.33μF.						
		No less than 3000ΩF : More than 0.33μF.						
	Dissipation factor (tanδ)	No more than initial specification at 1kHz.						
Capacitance change	Within ±5% of initial value.							

◆STANDARD RATINGS

WV (V _{dc})	Cap (μF)	Dimensions (mm)					Maximum ripple current (Arms)	WV (Vac)	Part Number	Previous Part Number (Just for your reference)
		W	H	T	F	φd				
250	0.82	16.2	10.8	10.3	10.0	0.8	5.45	100	FTACD251V824JDL CZ0	TACD2E824J
	1.0		11.6	11.1			6.00		FTACD251V105JDL CZ0	TACD2E105J
	1.2		12.5	11.9			6.57		FTACD251V125JDL CZ0	TACD2E125J
	1.5		13.6	13.0			7.34		FTACD251V155JDL CZ0	TACD2E155J
	1.8		14.7	14.0			8.04		FTACD251V185JDL CZ0	TACD2E185J
	2.2		15.9	15.2			8.89		FTACD251V225JDL CZ0	TACD2E225J
	2.7	23.2	14.0	13.4	17.5	0.8	6.66		FTACD251V275JEL HZ0	TACD2E275J
	3.3		15.2	14.5			7.36		FTACD251V335JEL HZ0	TACD2E335J
	3.9		16.4	15.6			8.00		FTACD251V395JEL HZ0	TACD2E395J
	4.7	28.2	17.8	16.9	22.5	1.0	8.78		FTACD251V475JEL HZ0	TACD2E475J
	5.6		17.1	16.3			7.87		FTACD251V565JFLE Z0	TACD2E565J
	6.8		18.7	17.8			8.67		FTACD251V685JFLE Z0	TACD2E685J
	8.2		20.3	19.3			9.52		FTACD251V825JFLE Z0	TACD2E825J
	10		22.2	21.2			10.00		FTACD251V106JFLE Z0	TACD2E106J
	12		24.1	23.0			10.00		FTACD251V126JFLE Z0	TACD2E126J
15	26.8	25.5	10.00	FTACD251V156JFLE Z0	TACD2E156J					
315	0.33	16.2	8.6	8.2	10.0	0.8	3.78	125	FTACD3B1V334JDL CZ0	TACD2F334J
	0.39		9.1	8.7			4.11		FTACD3B1V394JDL CZ0	TACD2F394J
	0.47		9.7	9.2			4.51		FTACD3B1V474JDL CZ0	TACD2F474J
	0.56		10.3	9.8			4.93		FTACD3B1V564JDL CZ0	TACD2F564J
	0.68		11.0	10.5			5.43		FTACD3B1V684JDL CZ0	TACD2F684J
	0.82		11.9	11.3			5.87		FTACD3B1V824JDL CZ0	TACD2F824J
	1.0	12.8	12.2	6.49	FTACD3B1V105JDL CZ0	TACD2F105J				
	1.2	18.2	12.9	12.3	12.5	0.8	6.23		FTACD3B1V125JHL GZ0	TACD2F125J
	1.5		14.1	13.4			6.96		FTACD3B1V155JHL GZ0	TACD2F155J
	1.8		15.2	14.5			7.63		FTACD3B1V185JHL GZ0	TACD2F185J
	2.2	23.2	14.4	13.7	17.5	1.0	6.49		FTACD3B1V225JEL HZ0	TACD2F225J
	2.7		15.6	14.9			7.19		FTACD3B1V275JEL HZ0	TACD2F275J
	3.3		17.1	16.3			7.95		FTACD3B1V335JEL HZ0	TACD2F335J
	3.9		18.3	17.5			8.65		FTACD3B1V395JEL HZ0	TACD2F395J
	4.7		19.9	19.0			9.34		FTACD3B1V475JEL HZ0	TACD2F475J
	5.6		28.2	19.3			18.4		22.5	1.0
	6.8	21.0		20.0	9.38	FTACD3B1V685JFLE Z0	TACD2F685J			
	8.2	22.9		21.8	10.00	FTACD3B1V825JFLE Z0	TACD2F825J			
	10	25.1		23.9	10.00	FTACD3B1V106JFLE Z0	TACD2F106J			
	12	27.3		26.0	10.00	FTACD3B1V126JFLE Z0	TACD2F126J			
	15	24.2		23.1	9.33	FTACD3B1V156JTL JZ0	TACD2F156J			
	18	43.2	26.3	25.1	37.5	1.0	10.00		FTACD3B1V186JTL JZ0	TACD2F186J
22	28.9		27.5	10.00			FTACD3B1V226JTL JZ0	TACD2F226J		

- (1)Capacitance tolerance:Standard(J:±5%),Option(K:±10%)
 (2)The maximum ripple current : +85°C max., 100kHz, sine wave
 (3)WV(V_{ac}) : 50Hz or 60Hz, sine wave

◆STANDARD RATINGS

WV (Vdc)	Cap (μF)	Dimensions (mm)					Maximum ripple current (Arms)	WV (Vac)	Part Number	Previous Part Number (Just for your reference)			
		W	H	T	F	φ φd							
400	0.22	16.2	8.7	8.3	10.0	0.8	3.91	150	FTACD401V224JDLCZO	TACD2G224J			
	0.27		9.3	8.9			4.33		FTACD401V274JDLCZO	TACD2G274J			
	0.33		10.0	9.5			4.27		FTACD401V334JDLCZO	TACD2G334J			
	0.39		10.6	10.1			4.64		FTACD401V394JDLCZO	TACD2G394J			
	0.47		11.4	10.8			5.09		FTACD401V474JDLCZO	TACD2G474J			
	0.56		12.2	11.6			5.56		FTACD401V564JDLCZO	TACD2G564J			
	0.68	18.2	13.1	12.5	12.5		6.13		FTACD401V684JDLCZO	TACD2G684J			
	0.82		13.2	12.6			5.89		FTACD401V824JHLGZO	TACD2G824J			
	1.0		14.3	13.7			6.50		FTACD401V105JHLGZO	TACD2G105J			
	1.2		13.4	12.8			5.71		FTACD401V125JELHZO	TACD2G125J			
	1.5	23.2	14.7	14.1	17.5		6.13		FTACD401V155JELHZO	TACD2G155J			
	1.8		15.9	15.2			6.71		FTACD401V185JELHZO	TACD2G185J			
	2.2		17.4	16.5			7.43		FTACD401V225JELHZO	TACD2G225J			
	2.7		19.0	18.1			8.23		FTACD401V275JELHZO	TACD2G275J			
	3.3	28.2	18.6	17.7	22.5		7.47		FTACD401V335JFLEZO	TACD2G335J			
	3.9		20.0	19.1			8.13		FTACD401V395JFLEZO	TACD2G395J			
	4.7		21.8	20.7			8.92		FTACD401V475JFLEZO	TACD2G475J			
	5.6		23.6	22.5			9.74		FTACD401V565JFLEZO	TACD2G565J			
	6.8		25.8	24.5			10.00		FTACD401V685JFLEZO	TACD2G685J			
	8.2		28.1	26.8			10.00		FTACD401V825JFLEZO	TACD2G825J			
500	0.22		18.2	9.6		9.2	12.5	0.8	150	FTACD501V224JHLGZO	TACD2H224J		
	0.27			10.2		9.8				3.42	FTACD501V274JHLGZO	TACD2H274J	
	0.33	11.1		10.6	3.78	FTACD501V334JHLGZO				TACD2H334J			
	0.39	11.7		11.2	4.11	FTACD501V394JHLGZO				TACD2H394J			
	0.47	12.7		12.1	4.51	FTACD501V474JHLGZO				TACD2H474J			
	0.56	13.6		13.0	4.93	FTACD501V564JHLGZO				TACD2H564J			
	0.68	23.2	14.7	14.0	17.5	5.43	FTACD501V684JHLGZO			TACD2H684J			
	0.82		15.9	15.2		5.96	FTACD501V824JHLGZO			TACD2H824J			
	1.0		14.9	14.2		5.08	FTACD501V105JELHZO			TACD2H105J			
	1.2		16.1	15.3		5.57	FTACD501V125JELHZO			TACD2H125J			
	1.5	28.2	17.6	16.8	22.5	6.23	FTACD501V155JELHZO			TACD2H155J			
	1.8		19.1	18.2		6.82	FTACD501V185JELHZO			TACD2H185J			
	2.2		20.9	19.9		7.54	FTACD501V225JELHZO			TACD2H225J			
	2.7		20.4	19.4		6.85	FTACD501V275JFLEZO			TACD2H275J			
	3.3	28.2	22.3	21.3	22.5	7.57	FTACD501V335JFLEZO			TACD2H335J			
	3.9		24.1	23.0		8.23	FTACD501V395JFLEZO			TACD2H395J			
	4.7		26.3	25.1		9.04	FTACD501V475JFLEZO			TACD2H475J			
	630		0.1	16.2		9.1	8.7			10.0	0.8	175	FTACD631V104JDLCZO
		0.12	9.6		9.2	3.28	FTACD631V124JDLCZO						TACD2J124J
		0.15	10.4		10.0	3.66	FTACD631V154JDLCZO						TACD2J154J
0.18		11.2	10.7		4.02	FTACD631V184JDLCZO	TACD2J184J						
0.22		12.0	11.5		4.44	FTACD631V224JDLCZO	TACD2J224J						
0.27		13.1	12.5		4.92	FTACD631V274JDLCZO	TACD2J274J						
0.33		18.2	13.1	12.5	12.5	4.76	FTACD631V334JHLGZO	TACD2J334J					
0.39			14.0	13.4		5.17	FTACD631V394JHLGZO	TACD2J394J					
0.47			15.2	14.5		5.68	FTACD631V474JHLGZO	TACD2J474J					
0.56			14.0	13.4		4.79	FTACD631V564JELHZO	TACD2J564J					
0.68		23.2	15.2	14.5	17.5	5.27	FTACD631V684JELHZO	TACD2J684J					
0.82			16.5	15.7		5.79	FTACD631V824JELHZO	TACD2J824J					
1.0			18.0	17.1		6.39	FTACD631V105JELHZO	TACD2J105J					
1.2			19.5	18.6		7.00	FTACD631V125JELHZO	TACD2J125J					
1.5		28.2	19.1	18.2	22.5	6.42	FTACD631V155JFLEZO	TACD2J155J					
1.8			20.8	19.8		7.04	FTACD631V185JFLEZO	TACD2J185J					
2.2			22.7	21.7		7.79	FTACD631V225JFLEZO	TACD2J225J					
2.7			25.0	23.8		8.62	FTACD631V275JFLEZO	TACD2J275J					
3.3		43.2	27.4	26.1	37.5	9.54	FTACD631V335JFLEZO	TACD2J335J					
3.9			23.9	22.8		6.93	FTACD631V395JTLJZO	TACD2J395J					
4.7	25.9		24.7	7.61		FTACD631V475JTLJZO	TACD2J475J						
5.6	28.1		26.8	8.31		FTACD631V565JTLJZO	TACD2J565J						

(1)Capacitance tolerance:Standard(J:±5%),Option(K:±10%)

(2)The maximum ripple current : +85°C max., 100kHz, sine wave

(3)WV(Vac) : 50Hz or 60Hz, sine wave

◆STANDARD RATINGS

WV (Vdc)	Cap (μF)	Dimensions (mm)					Maximum ripple current (Arms)	WV (Vac)	Part Number	Previous Part Number (Just for your reference)	
		W	H	T	F	φ φd					
800	0.056	16.2	8.5	8.1	10.0	0.8	2.60	200	FTACD801V563JDLCZ0	TACD2K563J	
	0.068		9.0	8.6			2.86		FTACD801V683JDLCZ0	TACD2K683J	
	0.082		9.6	9.2			3.14		FTACD801V823JDLCZ0	TACD2K823J	
	0.1		10.3	9.8			3.34		FTACD801V104JDLCZ0	TACD2K104J	
	0.12		11.0	10.5			3.66		FTACD801V124JDLCZ0	TACD2K124J	
	0.15	12.0	11.4	4.09	FTACD801V154JDLCZ0		TACD2K154J				
	0.18	18.2	12.4	11.8	12.5		3.92		FTACD801V184JHLGZ0	TACD2K184J	
	0.22		13.4	12.8			4.33		FTACD801V224JHLGZ0	TACD2K224J	
	0.27		14.6	13.9			4.80		FTACD801V274JHLGZ0	TACD2K274J	
	0.33	23.2	13.5	12.9	17.5		4.09		FTACD801V334JELHZ0	TACD2K334J	
	0.39		14.4	13.8			4.46		FTACD801V394JELHZ0	TACD2K394J	
	0.47		15.6	14.9			4.88		FTACD801V474JELHZ0	TACD2K474J	
	0.56		16.8	16.0			5.34		FTACD801V564JELHZ0	TACD2K564J	
	0.68		18.3	17.5			5.87		FTACD801V684JELHZ0	TACD2K684J	
	0.82	28.2	19.9	19.0	22.5		6.46		FTACD801V824JELHZ0	TACD2K824J	
	1.0		19.2	18.3			5.85		FTACD801V105JFLEZ0	TACD2K105J	
	1.2		20.8	19.9			6.41		FTACD801V125JFLEZ0	TACD2K125J	
	1.5		23.0	22.0			7.17		FTACD801V155JFLEZ0	TACD2K155J	
	1.8		25.1	23.9			7.85		FTACD801V185JFLEZ0	TACD2K185J	
	2.2	43.2	27.5	26.2	37.5		8.68		FTACD801V225JFLEZ0	TACD2K225J	
2.7	23.8		22.7	6.44		FTACD801V275JTLJZ0	TACD2K275J				
3.3	26.0		24.8	7.12		FTACD801V335JTLJZ0	TACD2K335J				
3.9	28.0		26.7	7.73		FTACD801V395JTLJZ0	TACD2K395J				
2.28	1000		8.9	8.5		10.0	0.8	2.28	250	FTACD102V333JDLCZ0	TACD3A333J
0.039		9.4	9.0	2.48	FTACD102V393JDLCZ0			TACD3A393J			
0.047		16.2	10.0	9.6	12.5			2.72		FTACD102V473JDLCZ0	TACD3A473J
0.056			10.7	10.2				2.97		FTACD102V563JDLCZ0	TACD3A563J
0.068			11.5	11.0				3.28		FTACD102V683JDLCZ0	TACD3A683J
0.082			12.4	11.8				3.60		FTACD102V823JDLCZ0	TACD3A823J
0.1			12.3	11.7				3.48		FTACD102V104JHLGZ0	TACD3A104J
0.12		18.2	13.2	12.6	17.5			3.81		FTACD102V124JHLGZ0	TACD3A124J
0.15			14.5	13.8				4.26		FTACD102V154JHLGZ0	TACD3A154J
0.18			13.3	12.7				3.60		FTACD102V184JELHZ0	TACD3A184J
0.22		23.2	14.4	13.8	22.5			3.97		FTACD102V224JELHZ0	TACD3A224J
0.27			15.8	15.0				4.40		FTACD102V274JELHZ0	TACD3A274J
0.33			17.2	16.4				4.86		FTACD102V334JELHZ0	TACD3A334J
0.39			18.5	17.6				5.29		FTACD102V394JELHZ0	TACD3A394J
0.47			20.1	19.1				5.81		FTACD102V474JELHZ0	TACD3A474J
0.56		28.2	19.2	18.3	22.5			5.21		FTACD102V564JFLEZ0	TACD3A564J
0.68			20.9	19.9				5.74		FTACD102V684JFLEZ0	TACD3A684J
0.82			22.8	21.7				6.30		FTACD102V824JFLEZ0	TACD3A824J
1.0			24.9	23.7				6.96		FTACD102V105JFLEZ0	TACD3A105J
1.2			27.1	25.8				7.62		FTACD102V125JFLEZ0	TACD3A125J

- (1)Capacitance tolerance:Standard(J:±5%),Option(K:±10%)
- (2)The maximum ripple current : +85°C max., 100kHz, sine wave
- (3)WV(Vac) : 50Hz or 60Hz, sine wave

◆DIMENSIONS (mm)

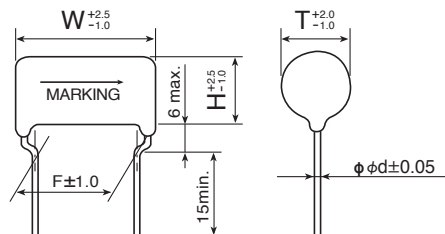



- Maximum operating temperature 105°C.
- Allowable temperature rise 15K max.
- Large capacitance of TACB series.

◆SPECIFICATIONS

Items	Characteristics				
Category temperature range	-40 to +105°C				
Rated voltage range	450 to 1000V _{dc}				
Capacitance tolerance	±5% (J)				
Voltage proof (Terminal - Terminal)	No degradation, at 150% of rated voltage shall be applied for 60 seconds.				
Dissipation factor (tanδ)	No more than 0.05% : Equal or less than 1μF. No more than (c×0.015+0.05)% : More than 1μF.				
Insulation resistance (Terminal - Terminal)	No less than 30000MΩ : Equal or less than 0.33μF. No less than 10000ΩF : More than 0.33μF.				
	Rated voltage (V _{dc})	450	630	800	1000
	Measurement voltage (V _{dc})	100	500	500	500
Endurance	The following specifications shall be satisfied, after 1000hrs with applying rated voltage×125% at 85°C.				
	Appearance	No serious degradation			
	Insulation resistance (Terminal - Terminal)	No less than 10000MΩ : Equal or less than 0.33μF. No less than 3000ΩF : More than 0.33μF.			
	Dissipation factor (tanδ)	No more than initial specification at 1kHz.			
	Capacitance change	Within ±5% of initial value.			
Loading under damp heat	The following specifications shall be satisfied, after 500hrs with applying rated voltage at 40°C 90~95%RH.				
	Appearance	No serious degradation.			
	Insulation resistance (Terminal - Terminal)	No less than 10000MΩ : Equal or less than 0.33μF. No less than 3000ΩF : More than 0.33μF.			
	Dissipation factor (tanδ)	No more than initial specification at 1kHz.			
	Capacitance change	Within ±5% of initial value.			

◆STANDARD RATINGS

WV (V _{dc})	Cap (μF)	Dimensions (mm)					Maximum ripple current (Arms)	WV (Vac)	Part Number	Previous Part Number (Just for your reference)
		W	H	T	F	φd				
450	5.6	33.2	21.0	20.0	27.5	1.0	7.0	115	FTACC451V565JRLFZ0	TACC2W565J
	6.8		22.9	21.9			7.7		FTACC451V685JRLFZ0	TACC2W685J
	8.2		25.0	23.8			8.5		FTACC451V825JRLFZ0	TACC2W825J
	10	27.4	26.1	9.4	FTACC451V106JLJLFZ0		TACC2W106J			
	12	43.2	25.7	24.5	7.5		FTACC451V126JTLJZ0		TACC2W126J	
	15	28.5	27.1	8.4	FTACC451V156JTLJZ0		TACC2W156J			
18	53.2	27.4	26.1	47.5	7.3	FTACC451V186JULWZ0	TACC2W186J			
630	3.3	33.2	21.5	20.4	27.5	1.0	5.6	150	FTACC631V335JRLFZ0	TACC2J335J
	3.9		23.2	22.1			6.1		FTACC631V395JRLFZ0	TACC2J395J
	4.7		25.2	24.0			6.7		FTACC631V475JRLFZ0	TACC2J475J
	5.6	27.4	26.1	7.3	FTACC631V565JRLFZ0		TACC2J565J			
	6.8	43.2	25.8	24.6	5.9		FTACC631V685JTLJZ0		TACC2J685J	
	8.2	28.0	26.7	6.5	FTACC631V825JTLJZ0		TACC2J825J			
10	53.2	27.3	26.0	47.5	5.6	FTACC631V106JULWZ0	TACC2J106J			
800	2.2	33.2	21.9	20.8	27.5	1.0	4.5	175	FTACC801V225JRLFZ0	TACC2K225J
	2.7		24.0	22.9			5.0		FTACC801V275JRLFZ0	TACC2K275J
	3.3		26.3	25.1			5.6		FTACC801V335JRLFZ0	TACC2K335J
	3.9	28.5	27.1	6.0	FTACC801V395JRLFZ0		TACC2K395J			
	4.7	43.2	26.8	25.5	4.9		FTACC801V475JTLJZ0		TACC2K475J	
	5.6	25.7	24.5	4.2	FTACC801V565JULWZ0		TACC2K565J			
6.8	53.2	28.0	26.7	47.5	4.6	FTACC801V685JULWZ0	TACC2K685J			
1000	1.0	33.2	23.4	22.3	27.5	1.0	3.9	200	FTACC102V105JRLFZ0	TACC3A105J
	1.2		25.5	24.3			4.2		FTACC102V125JRLFZ0	TACC3A125J
	1.5		28.2	26.9			4.7		FTACC102V155JRLFZ0	TACC3A155J
	1.8	43.2	26.4	25.2	3.8		FTACC102V185JTLJZ0		TACC3A185J	
	2.2	25.8	24.6	3.3	FTACC102V225JULWZ0		TACC3A225J			
	2.7	53.2	28.2	26.9	47.5		3.7		FTACC102V275JULWZ0	TACC3A275J

- (1)Capacitance tolerance : Standard (J: ±5%) , Option (K: ±10%)
- (2)The maximum ripple current : +85°C max., 100kHz, sine wave
- (3)WV(Vac) : 50Hz or 60Hz, sine wave

◆DIMENSIONS (mm)

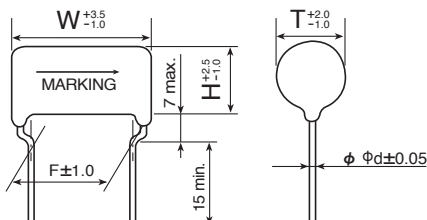



- Maximum operating temperature 105°C.
- Allowable temperature rise 15K max.
- A little hum is produced when applied AC voltage.

◆ SPECIFICATIONS

Items	Characteristics	
Category temperature range	-40 to +105°C	
Rated voltage range	250 to 800V _{dc}	
Capacitance tolerance	±5% (J)	
Voltage proof (Terminal - Terminal)	No degradation, at 150% of rated voltage shall be applied for 60 seconds.	
Dissipation factor (tanδ)	No more than 0.05% : Equal or less than 1μF. No more than (c×0.015+0.05)% : More than 1μF.	
Insulation resistance (Terminal - Terminal)	No less than 30000MΩ : Equal or less than 0.33μF.	
	No less than 10000ΩF : More than 0.33μF.	
	Rated voltage (V _{dc})	250 315 400 630 800
	Measurement voltage (V _{dc})	100 100 100 500 500
Endurance	The following specifications shall be satisfied, after 1000hrs with applying rated voltage×125% at 105°C.	
	Appearance	No serious degradation
	Insulation resistance (Terminal - Terminal)	No less than 10000MΩ : Equal or less than 0.33μF.
		No less than 3000ΩF : More than 0.33μF.
	Dissipation factor (tanδ)	No more than initial specification at 1kHz.
Capacitance change	Within ±5% of initial value.	
Loading under damp heat	The following specifications shall be satisfied, after 500hrs with applying rated voltage at 40°C 90~95%RH.	
	Appearance	No serious degradation.
	Insulation resistance (Terminal - Terminal)	No less than 10000MΩ : Equal or less than 0.33μF.
		No less than 3000ΩF : More than 0.3μF.
	Dissipation factor (tanδ)	No more than initial specification at 1kHz.
Capacitance change	Within ±5% of initial value.	

◆ STANDARD RATINGS

WV (V _{dc})	Cap (μF)	Dimensions (mm)					Maximum ripple current (Arms)	WV (Vac)	Part Number	Previous Part Number (Just for your reference)
		W	H	T	F	φd				
250	0.33	16.2	8.6	8.3	10.0	0.8	3.08	125	FTACB251V334JDLCZ0	TACB2E334J
	0.39		9.2	8.8			3.34		FTACB251V394JDLCZ0	TACB2E394J
	0.47		9.7	9.3			3.67		FTACB251V474JDLCZ0	TACB2E474J
	0.56		10.3	9.8			4.01		FTACB251V564JDLCZ0	TACB2E564J
	0.68		11.1	10.6			4.42		FTACB251V684JDLCZ0	TACB2E684J
	0.82		11.9	11.4			4.85		FTACB251V824JDLCZ0	TACB2E824J
	1.0	12.9	12.3	5.35	FTACB251V105JDLCZ0		TACB2E105J			
	1.2	12.9	12.3	5.03	FTACB251V125JHLGZ0		TACB2E125J			
	1.5	14.1	13.5	5.63	FTACB251V155JHLGZ0		TACB2E155J			
	1.8	15.2	14.5	6.17	FTACB251V185JHLGZ0		TACB2E185J			
	2.2	14.5	13.8	5.04	FTACB251V225JELHZ0		TACB2E225J			
	2.7	15.7	15.0	5.58	FTACB251V275JELHZ0		TACB2E275J			
	3.3	17.1	16.3	6.17	FTACB251V335JELHZ0		TACB2E335J			
	3.9	18.4	17.5	6.71	FTACB251V395JELHZ0		TACB2E395J			
	4.7	20.0	19.0	7.36	FTACB251V475JELHZ0		TACB2E475J			
	5.6	19.3	18.4	6.38	FTACB251V565JFLEZ0		TACB2E565J			
	6.8	21.0	20.0	7.03	FTACB251V685JFLEZ0		TACB2E685J			
	8.2	22.1	21.9	7.72	FTACB251V825JFLEZ0		TACB2E825J			
	10	25.2	24.0	8.52	FTACB251V106JFLEZ0		TACB2E106J			
	12	27.3	26.0	9.34	FTACB251V126JFLEZ0		TACB2E126J			
	15	24.2	23.1	6.45	FTACB251V156JTLJZ0		TACB2E156J			
	18	26.3	25.1	7.07	FTACB251V186JTLJZ0		TACB2E186J			
22	28.9	27.5	7.81	FTACB251V226JTLJZ0	TACB2E226J					
315	0.22	16.2	8.7	8.3	10.0	0.8	2.81	150	FTACB3B1V224JDLCZ0	TACB2F224J
	0.27		9.3	9.0			3.11		FTACB3B1V274JDLCZ0	TACB2F274J
	0.33		10.0	9.6			3.44		FTACB3B1V334JDLCZ0	TACB2F334J
	0.39		10.7	10.2			3.74		FTACB3B1V394JDLCZ0	TACB2F394J
	0.47		11.4	10.9			4.10		FTACB3B1V474JDLCZ0	TACB2F474J
	0.56		12.1	11.6			4.48		FTACB3B1V564JDLCZ0	TACB2F564J
	0.68	13.2	12.6	4.94	FTACB3B1V684JDLCZ0		TACB2F684J			
	0.82	13.2	12.6	4.65	FTACB3B1V824JHLGZ0		TACB2F824J			
	1.0	14.4	13.7	5.14	FTACB3B1V105JHLGZ0		TACB2F105J			

- (1) Capacitance tolerance : Standard (J:±5%), Option (K:±10%)
- (2) The maximum ripple current : +85°C max., 100kHz, sine wave
- (3) WV(Vac) : 50Hz or 60Hz, sine wave

◆STANDARD RATINGS

WV (Vdc)	Cap (μF)	Dimensions (mm)					Maximum ripple current (Arms)	WV (Vac)	Part Number	Previous Part Number (Just for your reference)			
		W	H	T	F	φd							
315	1.2	23.2	13.4	12.8	17.5	0.8	4.16	150	FTACB3B1V125JELHZO	TACB2F125J			
	1.5		14.8	14.1			4.65		FTACB3B1V155JELHZO	TACB2F155J			
	1.8		15.9	15.2			5.09		FTACB3B1V185JELHZO	TACB2F185J			
	2.2		17.3	16.5			5.63		FTACB3B1V225JELHZO	TACB2F225J			
	2.7		19.0	18.1			6.24		FTACB3B1V275JELHZO	TACB2F275J			
	3.3	28.2	18.6	17.7	22.5	1.0	5.47		FTACB3B1V335JFLEZO	TACB2F335J			
	3.9		20.0	19.0			5.95		FTACB3B1V395JFLEZO	TACB2F395J			
	4.7		21.8	20.7			6.53		FTACB3B1V475JFLEZO	TACB2F475J			
	5.6		23.6	22.5			7.13		FTACB3B1V565JFLEZO	TACB2F565J			
	6.8		25.8	24.6			7.86		FTACB3B1V685JFLEZO	TACB2F685J			
8.2	28.1	26.8	8.63	FTACB3B1V825JFLEZO	TACB2F825J								
400	0.1	16.2	9.2	8.8	10.0	0.8	2.40	175	FTACB401V104JDLCZO	TACB2G104J			
	0.12		9.7	9.3			2.62		FTACB401V124JDLCZO	TACB2G124J			
	0.15		10.5	10.1			2.93		FTACB401V154JDLCZO	TACB2G154J			
	0.18		11.2	10.7			3.21		FTACB401V184JDLCZO	TACB2G184J			
	0.22		12.1	11.6			3.55		FTACB401V224JDLCZO	TACB2G224J			
	0.27	18.2	13.1	12.5	12.5	0.8	3.94		FTACB401V274JDLCZO	TACB2G274J			
	0.33		13.2	12.6			3.71		FTACB401V334JHLGZO	TACB2G334J			
	0.39		14.1	13.5			4.04		FTACB401V394JHLGZO	TACB2G394J			
	0.47		15.2	14.5			4.43		FTACB401V474JHLGZO	TACB2G474J			
	0.56		14.1	13.5			3.54		FTACB401V564JELHZO	TACB2G564J			
	0.68	23.2	15.3	14.6	17.5	0.8	3.90		FTACB401V684JELHZO	TACB2G684J			
	0.82		16.6	15.8			4.29		FTACB401V824JELHZO	TACB2G824J			
	1.0		18.1	17.2			4.73		FTACB401V105JELHZO	TACB2G105J			
	1.2		19.6	18.6			5.19		FTACB401V125JELHZO	TACB2G125J			
	1.5		19.2	18.3			4.58		FTACB401V155JFLEZO	TACB2G155J			
	1.8	28.2	20.8	19.8	22.5	1.0	5.02		FTACB401V185JFLEZO	TACB2G185J			
	2.2		22.8	21.8			5.55		FTACB401V225JFLEZO	TACB2G225J			
	2.7		25.1	23.9			6.15		FTACB401V275JFLEZO	TACB2G275J			
	3.3		27.5	26.2			6.79		FTACB401V335JFLEZO	TACB2G335J			
	3.9		23.9	22.8			4.57		FTACB401V395JTLJZO	TACB2G395J			
4.7	43.2	25.9	24.7	37.5	1.0	5.02	FTACB401V475JTLJZO	TACB2G475J					
5.6		28.1	26.8			5.48	FTACB401V565JTLJZO	TACB2G565J					
630		0.056	16.2			8.5	8.2	10.0	0.8	1.96	200	FTACB631V563JDLCZO	TACB2J563J
		0.068				9.1	8.7			2.16		FTACB631V683JDLCZO	TACB2J683J
		0.082				9.6	9.2			2.38		FTACB631V823JDLCZO	TACB2J823J
	0.1	10.3		9.8	2.62	FTACB631V104JDLCZO	TACB2J104J						
	0.12	11.0		10.5	2.88	FTACB631V124JDLCZO	TACB2J124J						
	0.15	18.2	11.9	11.4	12.5	0.8	3.21	FTACB631V154JDLCZO	TACB2J154J				
	0.18		12.3	11.8			3.10	FTACB631V184JHLGZO	TACB2J184J				
	0.22		13.4	12.8			3.42	FTACB631V224JHLGZO	TACB2J224J				
	0.27		14.6	13.9			3.79	FTACB631V274JHLGZO	TACB2J274J				
	0.33		13.5	12.9			3.04	FTACB631V334JELHZO	TACB2J334J				
	0.39	23.2	14.5	13.8	17.5	0.8	3.30	FTACB631V394JELHZO	TACB2J394J				
	0.47		15.6	14.9			3.63	FTACB631V474JELHZO	TACB2J474J				
	0.56		16.8	16.0			3.96	FTACB631V564JELHZO	TACB2J564J				
	0.68		18.3	17.4			4.36	FTACB631V684JELHZO	TACB2J684J				
	0.82		19.9	18.9			4.79	FTACB631V824JELHZO	TACB2J824J				
	1.0	28.2	19.2	18.3	22.5	1.0	4.16	FTACB631V105JFLEZO	TACB2J105J				
	1.2		20.8	19.8			4.55	FTACB631V125JFLEZO	TACB2J125J				
	1.5		23.0	22.0			5.09	FTACB631V155JFLEZO	TACB2J155J				
	1.8		25.1	23.9			5.58	FTACB631V185JFLEZO	TACB2J185J				
	2.2		27.5	26.2			6.17	FTACB631V225JFLEZO	TACB2J225J				
2.7	43.2	23.8	22.7	37.5	1.0	4.17	FTACB631V275JTLJZO	TACB2J275J					
3.3		26.0	24.8			4.61	FTACB631V335JTLJZO	TACB2J335J					
3.9		28.0	26.7			5.01	FTACB631V395JTLJZO	TACB2J395J					

(1)Capacitance tolerance : Standard (J: ±5%) , Option (K:± 10%)

(2)The maximum ripple current : +85°Cmax., 100kHz, sine wave

(3)WV(Vac) : 50Hz or 60Hz, sine wave

◆STANDARD RATINGS

WV (Vdc)	Cap (μF)	Dimensions (mm)					Maximum ripple current (Arms)	WV (Vac)	Part Number	Previous Part Number (Just for your reference)
		W	H	T	F	φd				
800	0.033	16.2	9.0	8.6	10.0	0.8	1.81	250	FTACB801V333JDL CZ0	TACB2K333J
	0.039		9.5	9.1			1.97		FTACB801V393JDL CZ0	TACB2K393J
	0.047		10.1	9.7			2.16		FTACB801V473JDL CZ0	TACB2K473J
	0.056		10.8	10.3			2.36		FTACB801V563JDL CZ0	TACB2K563J
	0.068		11.5	11.0			2.60		FTACB801V683JDL CZ0	TACB2K683J
	0.082		12.5	11.9			2.85		FTACB801V823JDL CZ0	TACB2K823J
	0.1	18.2	12.3	11.8	12.5	0.8	2.67		FTACB801V104JHLGZ0	TACB2K104J
	0.12		13.3	12.7			2.92		FTACB801V124JHLGZ0	TACB2K124J
	0.15		14.6	13.9			3.26		FTACB801V154JHLGZ0	TACB2K154J
	0.18	23.2	13.4	12.8	17.5	0.8	2.59		FTACB801V184JELHZ0	TACB2K184J
	0.22		14.5	13.8			2.87		FTACB801V224JELHZ0	TACB2K224J
	0.27		15.8	15.1			3.17		FTACB801V274JELHZ0	TACB2K274J
	0.33		17.2	16.4			3.51		FTACB801V334JELHZ0	TACB2K334J
	0.39		18.5	17.6			3.82		FTACB801V394JELHZ0	TACB2K394J
	0.47		20.1	19.1			4.19		FTACB801V474JELHZ0	TACB2K474J
	0.56	28.2	19.2	18.3	22.5	1.0	3.59		FTACB801V564JFLEZ0	TACB2K564J
	0.68		20.9	19.9			3.96		FTACB801V684JFLEZ0	TACB2K684J
	0.82		22.8	21.8			4.35		FTACB801V824JFLEZ0	TACB2K824J
	1.0		25.0	23.8			4.80		FTACB801V105JFLEZ0	TACB2K105J
	1.2		27.2	25.9			5.26		FTACB801V125JFLEZ0	TACB2K125J

- (1)Capacitance tolerance:Standard(J:±5%),Option(K:±10%)
- (2)The maximum ripple current : +85°C max., 100kHz, sine wave
- (3)WV(Vac) : 50Hz or 60Hz, sine wave

◆DIMENSIONS (mm)

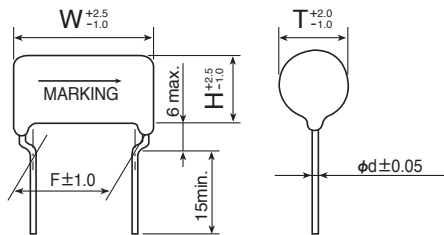

HACE Series



- Maximum operating temperature 105°C.
- A little hum is produced when applied AC voltage.
- Tab : 4 terminals

◆ SPECIFICATIONS

Items	Characteristics			
Category temperature range	-40 to +105°C			
Rated voltage range	630V _{dc} , 1250V _{dc} , 1600V _{dc} , 2000V _{dc}			
Capacitance tolerance	±5%(J)			
Voltage proof (Terminal - Terminal)	No degradation, at 150% of rated voltage shall be applied for 60 seconds.			
Dissipation factor (tanδ)	No more than 0.05% : Equal or less than 1μF. No more than (c×0.015+0.05)% : More than 1μF.			
Insulation resistance (Terminal - Terminal)	No less than 30000MΩ : Equal or less than 0.33μF.			
	No less than 10000ΩF : More than 0.33μF.			
	Rated voltage (V _{dc})	630	1250	2000
	Measurement voltage (V _{dc})	500	1000	1000
Endurance	The following specifications shall be satisfied, after 1000hrs with applying rated voltage×125% at 105°C.			
	Appearance	No serious degradation		
	Insulation resistance (Terminal - Terminal)	No less than 10000MΩ : Equal or less than 0.33μF.		
		No less than 3000ΩF : More than 0.33μF.		
	Dissipation factor (tanδ)	Not more than initial specification at 1kHz.		
Loading under damp heat	The following specifications shall be satisfied, after 500hrs with applying rated voltage at 40°C 90~95%RH.			
	Appearance	No serious degradation.		
	Insulation resistance (Terminal - Terminal)	No less than 10000MΩ : Equal or less than 0.33μF.		
		No less than 3000ΩF : More than 0.33μF.		
	Dissipation factor (tanδ)	Not more than initial specification at 1kHz.		
	Capacitance change	Within ±5% of initial value.		

◆ STANDARD RATINGS

WV (V _{dc})	Cap (μF)	Dimensions (mm)				Maximum ripple current (Arms)	WV (Vac)	Part Number
		W	H	T	P			
630	0.47	18.5	26.1	24.9	16.5	10.5	300	FHACE631N474J0A0S0
	0.68	23.5	25.3	24.1	21.5	11.1		FHACE631N684J1A1S0
	1.0		29.8	28.3		13.5		FHACE631N105J1A1S0
	1.5		31.5	30.0		26.5		13.5
1250	0.47	28.5	29.1	27.7	26.5	10.1	400	FHACE1C2N474J2A2S0
	0.68		34.5	32.8		12.0		FHACE1C2N684J2A2S0
	1.0	43.5	30.8	29.3	41.5	12.0		FHACE1C2N105J4A4S0
	1.5	53.5	32.5	31.0	51.5	13.5		FHACE1C2N155J5A5S0
1600	0.27	28.5	30.2	28.8	26.5	9.6	450	FHACE162N274J2A2S0
	0.33		33.2	31.6		10.6		FHACE162N334J2A2S0
2000	0.18	28.5	30.8	29.3	26.5	8.8	450	FHACE202N184J2A2S0
	0.22		33.8	32.2		9.7		FHACE202N224J2A2S0

- (1) The maximum ripple current : +85°C max, 100KHz, sine wave
(2) WV(Vac) : 50Hz or 60Hz, sine wave

◆ DIMENSIONS

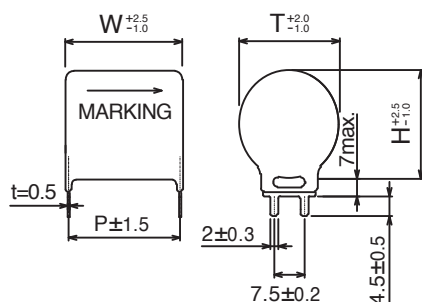

The recommended conditions for mounting.

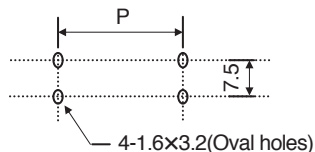

HACD Series



- Maximum operating temperature 105°C .
- Allowable temperature rise 15K max.
- Downsizing of HACB series.



◆SPECIFICATIONS

Items	Characteristics									
Category temperature range	-40 to +105°C									
Rated voltage range	630 to 4000V _{dc}									
Capacitance tolerance	±5%(J)									
Voltage proof (Terminal - Terminal)	No degradation, at 150% of rated voltage shall be applied for 60 seconds.									
Dissipation factor (tanδ)	No more than 0.05% : Equal or less than 1μF. No more than (c × 0.015 + 0.05)% : More than 1μF.									
Insulation resistance (Terminal - Terminal)	No less than 30000MΩ : Equal or less than 0.33μF. No less than 10000ΩF : More than 0.33μF.									
	Rated voltage (V _{dc})	630	1000	1250	1600	2000	2500	3150	4000	
	Measurement voltage (V _{dc})	500	1000	1000	1000	1000	1000	1000	1000	
Endurance	The following specifications shall be satisfied, after 1000hrs with applying rated voltage × 125% at 105°C .									
	Appearance	No serious degradation								
	Insulation resistance (Terminal - Terminal)	No less than 10000MΩ : Equal or less than 0.33μF. No less than 3000ΩF : More than 0.33μF.								
	Dissipation factor (tanδ)	Not more than initial specification at 1kHz.								
	Capacitance change	Within ±5% of initial value.								
Loading under damp heat	The following specifications shall be satisfied, after 500hrs with applying rated voltage at 40°C 90~95%RH.									
	Appearance	No serious degradation.								
	Insulation resistance (Terminal - Terminal)	No less than 10000MΩ : Equal or less than 0.33μF. No less than 3000ΩF : More than 0.33μF.								
	Dissipation factor (tanδ)	Not more than initial specification at 1kHz.								
	Capacitance change	Within ±5% of initial value.								

◆STANDARD RATINGS

WV (V _{dc})	Cap (μF)	Dimensions (mm)					Maximum ripple current (Arms)	WV (Vac)	Part Number	Previous Part Number (Just for your reference)
		W	H	T	F	φd				
630	0.047	17.7	9.8	9.3	12.5	0.8	2.65	250	FHACD631V473J0LGZ0	HACD2J473J
	0.056		10.4	10.0			2.89		FHACD631V563J0LGZ0	HACD2J563J
	0.068		11.0	10.5			3.19		FHACD631V683J0LGZ0	HACD2J683J
	0.082		11.6	11.1			3.50		FHACD631V823J0LGZ0	HACD2J823J
	0.1		12.3	11.7			3.86		FHACD631V104J0LGZ0	HACD2J104J
	0.12		13.1	12.5			4.23		FHACD631V124J0LGZ0	HACD2J124J
	0.15	14.1	13.5	4.73	FHACD631V154J0LGZ0	HACD2J154J				
	0.18	15.1	14.4	5.18	FHACD631V184J0LGZ0	HACD2J184J				
	0.22	13.8	13.2	4.31	FHACD631V224J1LHZ0	HACD2J224J				
	0.27	14.9	14.2	4.78	FHACD631V274J1LHZ0	HACD2J274J				
	0.33	16.1	15.3	5.28	FHACD631V334J1LHZ0	HACD2J334J				
	0.39	17.1	16.3	5.74	FHACD631V394J1LHZ0	HACD2J394J				
	0.47	18.5	17.6	6.30	FHACD631V474J1LHZ0	HACD2J474J				
	0.56	19.9	18.9	6.88	FHACD631V564J1LHZ0	HACD2J564J				
	0.68	19.0	18.1	6.19	FHACD631V684J2LEZ0	HACD2J684J				
	0.82	20.5	19.6	6.79	FHACD631V824J2LEZ0	HACD2J824J				
	1.0	22.3	21.3	7.50	FHACD631V105J2LEZ0	HACD2J105J				
	1.2	24.2	23.0	8.22	FHACD631V125J2LEZ0	HACD2J125J				
1.5	26.7	25.4	9.19	FHACD631V155J2LEZ0	HACD2J155J					
1000	0.033	17.7	10.0	9.6	12.5	0.8	2.43	270	FHACD102V333J0LGZ0	HACD3A333J
	0.039		10.4	10.0			2.64		FHACD102V393J0LGZ0	HACD3A393J
	0.047		11.0	10.5			2.90		FHACD102V473J0LGZ0	HACD3A473J
	0.056		11.5	11.0			3.17		FHACD102V563J0LGZ0	HACD3A563J
	0.068		12.2	11.7			3.49		FHACD102V683J0LGZ0	HACD3A683J
	0.082		13.0	12.4			3.83		FHACD102V823J0LGZ0	HACD3A823J
	0.1	13.9	13.3	4.23	FHACD102V104J0LGZ0	HACD3A104J				
	0.12	14.9	14.2	4.64	FHACD102V124J0LGZ0	HACD3A124J				
	0.15	13.7	13.1	3.90	FHACD102V154J1LHZ0	HACD3A154J				
	0.18	14.7	14.0	4.27	FHACD102V184J1LHZ0	HACD3A184J				
	0.22	15.8	15.1	4.72	FHACD102V224J1LHZ0	HACD3A224J				
	0.27	17.1	16.3	5.23	FHACD102V274J1LHZ0	HACD3A274J				
	0.33	18.6	17.7	5.79	FHACD102V334J1LHZ0	HACD3A334J				
	0.39	19.9	19.0	6.29	FHACD102V394J1LHZ0	HACD3A394J				

- (1)The maximum ripple current : +85°C max., 100kHz, sine wave
(2)WV(Vac) : 50Hz or 60Hz, sine wave

◆STANDARD RATINGS

WV (Vdc)	Cap (μF)	Dimensions (mm)					Maximum ripple current (Arms)	WV (Vac)	Part Number	Previous Part Number (Just for your reference)	
		W	H	T	F	φd					
1000	0.47	27.7	18.9	18.0	22.5	1.0	5.63	270	FHACD102V474J2LEZ0	HACD3A474J	
	0.56		20.4	19.4			6.15		FHACD102V564J2LEZ0	HACD3A564J	
	0.68		22.1	21.1			6.78		FHACD102V684J2LEZ0	HACD3A684J	
	0.82		24.0	22.9			7.44		FHACD102V824J2LEZ0	HACD3A824J	
	1.0		26.2	25.0			8.22		FHACD102V105J2LEZ0	HACD3A105J	
	1.2		28.5	27.1			9.00		FHACD102V125J2LEZ0	HACD3A125J	
1250	0.018	17.7	9.7	9.3	12.5	0.8	2.04	300	FHACD1C2V183J0LGZ0	HACD3B183J	
	0.022		10.4	9.9			2.25		FHACD1C2V223J0LGZ0	HACD3B223J	
	0.027		11.0	10.5			2.50		FHACD1C2V273J0LGZ0	HACD3B273J	
	0.033		11.6	11.1			2.76		FHACD1C2V333J0LGZ0	HACD3B333J	
	0.039		12.3	11.7			3.00		FHACD1C2V393J0LGZ0	HACD3B393J	
	0.047		13.0	12.4			3.29		FHACD1C2V473J0LGZ0	HACD3B473J	
	0.056	13.8	13.2	3.60	FHACD1C2V563J0LGZ0	HACD3B563J					
	0.068	14.8	14.2	3.96	FHACD1C2V683J0LGZ0	HACD3B683J					
	0.082	15.3	12.7	3.24	FHACD1C2V823J1LHZ0	HACD3B823J					
	0.1	14.3	13.6	3.57	FHACD1C2V104J1LHZ0	HACD3B104J					
	0.12	15.3	14.6	3.91	FHACD1C2V124J1LHZ0	HACD3B124J					
	0.15	16.7	15.9	4.38	FHACD1C2V154J1LHZ0	HACD3B154J					
	0.18	17.9	17.1	4.79	FHACD1C2V184J1LHZ0	HACD3B184J					
	0.22	19.5	18.6	5.30	FHACD1C2V224J1LHZ0	HACD3B224J					
	0.27	18.5	17.7	4.77	FHACD1C2V274J2LEZ0	HACD3B274J					
	0.33	20.1	19.2	5.28	FHACD1C2V334J2LEZ0	HACD3B334J					
	0.39	21.6	20.6	5.74	FHACD1C2V394J2LEZ0	HACD3B394J					
	0.47	23.4	22.3	6.30	FHACD1C2V474J2LEZ0	HACD3B474J					
	0.56	25.3	24.1	6.87	FHACD1C2V564J2LEZ0	HACD3B564J					
	0.68	27.6	26.3	7.58	FHACD1C2V684J2LEZ0	HACD3B684J					
	0.82	23.2	22.1	5.55	FHACD1C2V824JTLJZ0	HACD3B824J					
	1.0	25.4	24.2	6.13	FHACD1C2V105JTLJZ0	HACD3B105J					
	1.2	27.5	26.2	6.72	FHACD1C2V125JTLJZ0	HACD3B125J					
	1600	0.0068	19.7	10.0	9.5	15.0	0.8	1.49	350	FHACD162V682JKLDZ0	HACD3C682J
0.0082		10.6		10.1	1.80			FHACD162V822JKLDZ0		HACD3C822J	
0.01		11.2		10.6	2.09			FHACD162V103JKLDZ0		HACD3C103J	
0.012		11.8		11.2	2.29			FHACD162V123JKLDZ0		HACD3C123J	
0.015		12.6		12.0	2.56			FHACD162V153JKLDZ0		HACD3C153J	
0.018		13.4		12.8	2.80			FHACD162V183JKLDZ0		HACD3C183J	
0.022		14.4	13.7	3.10	FHACD162V223JKLDZ0	HACD3C223J					
0.027		15.0	14.3	3.43	FHACD162V273JKLDZ0	HACD3C273J					
0.033		16.3	15.5	3.80	FHACD162V333JKLDZ0	HACD3C333J					
0.039		13.0	12.4	2.60	FHACD162V393J1LHZ0	HACD3C393J					
0.047		13.8	13.2	2.85	FHACD162V473J1LHZ0	HACD3C473J					
0.056		14.7	14.0	3.11	FHACD162V563J1LHZ0	HACD3C563J					
0.068		15.8	15.1	3.43	FHACD162V683J1LHZ0	HACD3C683J					
0.082		17.0	16.2	3.77	FHACD162V823J1LHZ0	HACD3C823J					
0.1		18.4	17.6	4.16	FHACD162V104J1LHZ0	HACD3C104J					
0.12		17.2	16.4	3.68	FHACD162V124J2LEZ0	HACD3C124J					
0.15		18.9	18.0	4.12	FHACD162V154J2LEZ0	HACD3C154J					
0.18		20.4	19.4	4.51	FHACD162V184J2LEZ0	HACD3C184J					
0.22		22.2	21.1	4.99	FHACD162V224J2LEZ0	HACD3C224J					
0.27		24.2	23.1	5.53	FHACD162V274J2LEZ0	HACD3C274J					
0.33		26.5	25.3	6.11	FHACD162V334J2LEZ0	HACD3C334J					
2000		0.0033	19.7	9.3	8.9	15.0	0.8	0.73	350	FHACD202V332JKLDZ0	HACD3D332J
		0.0039		9.7	9.2			0.85		FHACD202V392JKLDZ0	HACD3D392J
		0.0047		10.2	9.7			1.03		FHACD202V472JKLDZ0	HACD3D472J
	0.0056	10.9		10.4	1.23			FHACD202V562JKLDZ0		HACD3D562J	
	0.0068	11.8		11.2	1.50			FHACD202V682JKLDZ0		HACD3D682J	
	0.0082	12.6		12.0	1.80			FHACD202V822JKLDZ0		HACD3D822J	
	0.01	13.5		12.9	2.20			FHACD202V103JKLDZ0		HACD3D103J	
	0.012	14.4		13.7	2.63			FHACD202V123JKLDZ0		HACD3D123J	
	0.015	15.6		14.9	2.97			FHACD202V153JKLDZ0		HACD3D153J	
	0.018	16.7		16.0	3.26			FHACD202V183JKLDZ0		HACD3D183J	

(1)The maximum ripple current : +85°C max., 100kHz, sine wave

(2)WV(Vac) : 50Hz or 60Hz, sine wave

◆ STANDARD RATINGS

WV (Vdc)	Cap (μF)	Dimensions (mm)					Maximum ripple current (Arms)	WV (Vac)	Part Number	Previous Part Number (Just for your reference)					
		W	H	T	F	φd									
2000	0.022	22.7	13.1	12.5	17.5	0.8	2.27	350	FHACD202V223J1LHZ0	HACD3D223J					
	0.027		14.0	13.4			2.51		FHACD202V273J1LHZ0	HACD3D273J					
	0.033		15.1	14.4			2.78		FHACD202V333J1LHZ0	HACD3D333J					
	0.039		16.1	15.3			3.02		FHACD202V393J1LHZ0	HACD3D393J					
	0.047		17.3	16.5			3.32		FHACD202V473J1LHZ0	HACD3D473J					
	0.056	18.6	17.7	3.62	FHACD202V563J1LHZ0	HACD3D563J									
	0.068	17.5	16.6	3.22	FHACD202V683J2LEZ0	HACD3D683J									
	0.082	18.8	18.0	3.54	FHACD202V823J2LEZ0	HACD3D823J									
	0.1	20.5	19.5	3.91	FHACD202V104J2LEZ0	HACD3D104J									
	0.12	22.1	21.1	4.28	FHACD202V124J2LEZ0	HACD3D124J									
	0.15	24.4	23.2	4.79	FHACD202V154J2LEZ0	HACD3D154J									
	0.18	26.4	25.2	5.24	FHACD202V184J2LEZ0	HACD3D184J									
	0.22	22.6	21.5	3.93	FHACD202V224JTLJZ0	HACD3D224J									
	0.27	24.7	23.5	4.35	FHACD202V274JTLJZ0	HACD3D274J									
	0.33	27.0	25.7	4.81	FHACD202V334JTLJZ0	HACD3D334J									
2500	0.015	34.7	11.7	11.2	30.0	1.0	2.11	500	FHACD252V153JRLQZ0	HACD3E153J					
	0.018		12.6	12.0			2.31		FHACD252V183JRLQZ0	HACD3E183J					
	0.022		13.7	13.0			2.55		FHACD252V223JRLQZ0	HACD3E223J					
	0.027		14.9	14.2			2.83		FHACD252V273JRLQZ0	HACD3E273J					
	0.033		16.2	15.4			3.13		FHACD252V333JRLQZ0	HACD3E333J					
	0.039		17.4	16.6			3.40		FHACD252V393JRLQZ0	HACD3E393J					
	0.047		18.9	18.0			3.73		FHACD252V473JRLQZ0	HACD3E473J					
	0.056		20.4	19.5			4.07		FHACD252V563JRLQZ0	HACD3E563J					
	0.068		22.3	21.3			4.49		FHACD252V683JRLQZ0	HACD3E683J					
	0.082		24.3	23.1			4.93		FHACD252V823JRLQZ0	HACD3E823J					
	0.1		26.6	25.4			5.44		FHACD252V104JRLQZ0	HACD3E104J					
	3150		0.0068	34.7			11.5		11.0	30.0	1.0	1.64	630	FHACD3B2V682JRLQZ0	HACD3F682J
0.0082		12.4	11.8		1.80	FHACD3B2V822JRLQZ0	HACD3F822J								
0.01		13.4	12.8		1.99	FHACD3B2V103JRLQZ0	HACD3F103J								
0.012		14.4	13.7		2.18	FHACD3B2V123JRLQZ0	HACD3F123J								
0.015		15.8	15.1		2.44	FHACD3B2V153JRLQZ0	HACD3F153J								
0.018		17.1	16.3		2.67	FHACD3B2V183JRLQZ0	HACD3F183J								
0.022		18.7	17.8		2.95	FHACD3B2V223JRLQZ0	HACD3F223J								
0.027		20.5	19.5		3.27	FHACD3B2V273JRLQZ0	HACD3F273J								
0.033		22.4	21.4		3.62	FHACD3B2V333JRLQZ0	HACD3F333J								
0.039		24.2	23.1		3.93	FHACD3B2V393JRLQZ0	HACD3F393J								
0.047		26.4	25.1		4.31	FHACD3B2V473JRLQZ0	HACD3F473J								
4000		0.0039	34.7		11.2	10.6	30.0	1.0	1.63			720		FHACD402V392JRLQZ0	HACD3G392J
		0.0047			12.0	11.4			1.79					FHACD402V472JRLQZ0	HACD3G472J
		0.0056			12.8	12.2			1.95					FHACD402V562JRLQZ0	HACD3G562J
		0.0068			13.9	13.2			2.15					FHACD402V682JRLQZ0	HACD3G682J
	0.0082	15.0		14.3	2.36	FHACD402V822JRLQZ0			HACD3G822J						
	0.01	16.3		15.6	2.60	FHACD402V103JRLQZ0			HACD3G103J						
	0.012	17.7		16.8	2.85	FHACD402V123JRLQZ0			HACD3G123J						
	0.015	19.5		18.6	3.19	FHACD402V153JRLQZ0			HACD3G153J						
	0.018	21.2		20.2	3.49	FHACD402V183JRLQZ0			HACD3G183J						
	0.022	23.2		22.1	3.86	FHACD402V223JRLQZ0			HACD3G223J						
	0.027	25.5		24.2	4.28	FHACD402V273JRLQZ0			HACD3G273J						

- (1) The maximum ripple current : +85°C max., 100kHz, sine wave
(2) WV(Vac) : 50Hz or 60Hz, sine wave

◆ DIMENSIONS (mm)

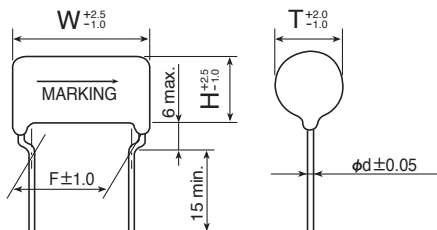



- Maximum operating temperature 105°C.
- Allowable temperature rise 15K max.
- A little hum is produced when applied AC voltage.

◆ SPECIFICATIONS

Items	Characteristics							
Category temperature range	-40 to +105°C							
Rated voltage range	630 to 4000V _{dc}							
Capacitance tolerance	J: ±5%							
Voltage proof (Terminal - Terminal)	No degradation, at 150% of rated voltage shall be applied for 60 seconds.							
Dissipation factor (tanδ)	No more than 0.05% : Equal or less than 1μF. No more than (c×0.015+0.05)% : More than 1μF.							
Insulation resistance (Terminal - Terminal)	No less than 30000MΩ : Equal or less than 0.33μF.							
	No less than 10000ΩF : More than 0.33μF.							
	Rated voltage (V _{dc})	630	1000	1250	1600	2000	3150	4000
	Measurement voltage (V _{dc})	500	1000	1000	1000	1000	1000	1000
Endurance	The following specifications shall be satisfied, after 1000hrs with applying rated voltage x 125% at 105°C.							
	Appearance	No serious degradation						
	Insulation resistance (Terminal - Terminal)	No less than 10000MΩ : Equal or less than 0.33μF.						
		No less than 3000ΩF : More than 0.33μF.						
	Dissipation factor (tanδ)	Not more than initial specification at 1kHz.						
Loading under damp heat	The following specifications shall be satisfied, after 500hrs with applying rated voltage at 40°C 90~95%RH.							
	Appearance	No serious degradation.						
	Insulation resistance (Terminal - Terminal)	No less than 10000MΩ : Equal or less than 0.33μF.						
		No less than 3000ΩF : More than 0.33μF.						
	Dissipation factor (tanδ)	Not more than initial specification at 1kHz.						
	Capacitance change	Within ±5% of initial value.						

◆ STANDARD RATINGS

WV (V _{dc})	Cap (μF)	Dimensions (mm)					Maximum ripple current (Arms)	WV (Vac)	Part Number	Previous Part Number (Just for your reference)
		W	H	T	F	φd				
630	0.033	17.7	8.7	8.3	12.5	0.8	3.50	300	FHACB631V333J0LGZ0	HACB2J333J
	0.039		9.3	8.8			3.81		FHACB631V393J0LGZ0	HACB2J393J
	0.047		9.8	9.3			4.18		FHACB631V473J0LGZ0	HACB2J473J
	0.056		10.4	10.0			4.56		FHACB631V563J0LGZ0	HACB2J563J
	0.068		11.3	10.8			5.03		FHACB631V683J0LGZ0	HACB2J683J
	0.082		12.1	11.6			5.52		FHACB631V823J0LGZ0	HACB2J823J
	0.1	13.1	12.5	6.10	FHACB631V104J0LGZ0		HACB2J104J			
	0.12	14.0	13.4	6.68	FHACB631V124J0LGZ0		HACB2J124J			
	0.15	12.9	12.3	5.67	FHACB631V154J1LHZ0		HACB2J154J			
	0.18	13.8	13.2	6.21	FHACB631V184J1LHZ0		HACB2J184J			
	0.22	15.1	14.4	6.87	FHACB631V224J1LHZ0		HACB2J224J			
	0.27	16.5	15.7	7.61	FHACB631V274J1LHZ0		HACB2J274J			
	0.33	18.0	17.1	8.41	FHACB631V334J1LHZ0		HACB2J334J			
	0.39	19.3	18.4	9.15	FHACB631V394J1LHZ0		HACB2J394J			
	0.47	18.4	17.5	8.24	FHACB631V474J2LEZ0		HACB2J474J			
	0.56	19.9	18.9	9.00	FHACB631V564J2LEZ0		HACB2J564J			
	0.68	21.7	20.6	9.34	FHACB631V684J2LEZ0		HACB2J684J			
	0.82	23.6	22.5	10.0	FHACB631V824J2LEZ0		HACB2J824J			
1.0	25.8	24.6	10.0	FHACB631V105J2LEZ0	HACB2J105J					
1.2	28.1	26.8	10.0	FHACB631V125J2LEZ0	HACB2J125J					
1000	0.018	17.7	8.6	8.3	12.5	0.8	3.00	350	FHACB102V183J0LGZ0	HACB3A183J
	0.022		9.3	8.8			3.32		FHACB102V223J0LGZ0	HACB3A223J
	0.027		9.8	9.5			3.68		FHACB102V273J0LGZ0	HACB3A273J
	0.033		10.7	10.2			4.06		FHACB102V333J0LGZ0	HACB3A333J
	0.039		11.3	10.8			4.42		FHACB102V393J0LGZ0	HACB3A393J
	0.047		12.1	11.6			4.85		FHACB102V473J0LGZ0	HACB3A473J
	0.056	13.0	12.4	5.29	FHACB102V563J0LGZ0		HACB3A563J			
	0.068	14.0	13.4	5.83	FHACB102V683J0LGZ0		HACB3A683J			
	0.082	12.5	11.9	4.78	FHACB102V823J1LHZ0		HACB3A823J			
	0.1	13.5	12.9	5.28	FHACB102V104J1LHZ0		HACB3A104J			
	0.12	14.6	13.9	5.79	FHACB102V124J1LHZ0		HACB3A124J			
	0.15	16.1	15.3	6.47	FHACB102V154J1LHZ0		HACB3A154J			
	0.18	17.3	16.5	7.09	FHACB102V184J1LHZ0		HACB3A184J			
	0.22	18.9	18.0	7.83	FHACB102V224J1LHZ0		HACB3A224J			

- (1) Capacitance tolerance: Standard (J: ±5%), Option (H: ±3%)
- (2) The maximum ripple current : +85°C max., 100kHz, sine wave
- (3) WV(Vac) : 50Hz or 60Hz, sine wave

◆STANDARD RATINGS

WV (Vdc)	Cap (μF)	Dimensions (mm)					Maximum ripple current (Arms)	WV (Vac)	Part Number	Previous Part Number (Just for your reference)		
		W	H	T	F	φd						
1000	0.27	27.7	18.0	17.1	22.5	1.0	7.07	350	FHACB102V274 J2LEZO	HACB3A274J		
	0.33		19.6	18.6			7.82		FHACB102V334 J2LEZO	HACB3A334J		
	0.39		21.1	20.1			8.50		FHACB102V394 J2LEZO	HACB3A394J		
	0.47		22.9	21.9			9.34		FHACB102V474 J2LEZO	HACB3A474J		
	0.56		25.0	23.8			10.0		FHACB102V564 J2LEZO	HACB3A564J		
	0.68		27.3	26.0			10.0		FHACB102V684 J2LEZO	HACB3A684J		
	0.82	42.7	22.8	21.8	37.5		8.44		FHACB102V824 J4LJZO	HACB3A824J		
	1.0		25.0	23.8			9.34		FHACB102V105 J4LJZO	HACB3A105J		
	1.2		27.1	25.8			10.0		FHACB102V125 J4LJZO	HACB3A125J		
1250	0.012	17.7	8.5	8.2	12.5	0.8	2.68	400	FHACB1C2V123J0LGZO	HACB3B123J		
	0.015		9.2	8.8			3.00		FHACB1C2V153J0LGZO	HACB3B153J		
	0.018		9.8	9.3			3.29		FHACB1C2V183J0LGZO	HACB3B183J		
	0.022		10.5	10.1			3.63		FHACB1C2V223J0LGZO	HACB3B223J		
	0.027		11.3	10.8			4.03		FHACB1C2V273J0LGZO	HACB3B273J		
	0.033		12.2	11.7			4.45		FHACB1C2V333J0LGZO	HACB3B333J		
	0.039	13.1	12.5	4.84	FHACB1C2V393J0LGZO		HACB3B393J					
	0.047	14.0	13.4	5.31	FHACB1C2V473J0LGZO		HACB3B473J					
	0.056	22.7	13.3	12.7	17.5		4.61		FHACB1C2V563J1LHZO	HACB3B563J		
	0.068		14.4	13.7			5.08		FHACB1C2V683J1LHZO	HACB3B683J		
	0.082		15.5	14.8			5.58		FHACB1C2V823J1LHZO	HACB3B823J		
	0.1	27.7	16.9	16.1	22.5		6.16		FHACB1C2V104J1LHZO	HACB3B104J		
	0.12		18.4	17.5			6.75		FHACB1C2V124J1LHZO	HACB3B124J		
	0.15		17.2	16.4			6.02		FHACB1C2V154J2LEZO	HACB3B154J		
	0.18		18.6	17.7			6.60		FHACB1C2V184J2LEZO	HACB3B184J		
	0.22		20.3	19.3			7.29		FHACB1C2V224J2LEZO	HACB3B224J		
	0.27		22.3	21.3			8.08		FHACB1C2V274J2LEZO	HACB3B274J		
	0.33		24.4	23.3			8.93		FHACB1C2V334J2LEZO	HACB3B334J		
	0.39		26.3	25.1			9.34		FHACB1C2V394J2LEZO	HACB3B394J		
	0.47		21.9	20.8			7.10		FHACB1C2V474J4LJZO	HACB3B474J		
	0.56		42.7	23.7			22.6		37.5	7.75	FHACB1C2V564J4LJZO	HACB3B564J
	0.68			25.8			24.6			8.54	FHACB1C2V684J4LJZO	HACB3B684J
	0.82			27.6			26.3			9.34	FHACB1C2V824J4LJZO	HACB3B824J
	1.0	52.7	27.0	25.7	47.5		8.57		FHACB1C2V105JULWZO	HACB3B105J		
1600	0.0047	19.7	8.8	8.5	15.0	0.8	1.32	450	FHACB162V472 JKLDZO	HACB3C472J		
	0.0056		9.3	9.0			1.58		FHACB162V562 JKLDZO	HACB3C562J		
	0.0068		10.0	9.6			1.93		FHACB162V682 JKLDZO	HACB3C682J		
	0.0082		10.7	10.2			2.32		FHACB162V822 JKLDZO	HACB3C822J		
	0.01		11.5	11.0			2.83		FHACB162V103 JKLDZO	HACB3C103J		
	0.012		12.3	11.8			3.39		FHACB162V123 JKLDZO	HACB3C123J		
	0.015	13.5	12.9	4.24	FHACB162V153 JKLDZO		HACB3C153J					
	0.018	14.6	13.9	4.47	FHACB162V183 JKLDZO		HACB3C183J					
	0.022	15.8	15.1	4.94	FHACB162V223 JKLDZO		HACB3C223J					
	0.027	22.7	13.0	12.4	17.5		3.86		FHACB162V273 J1LHZO	HACB3C273J		
	0.033		14.0	13.4			4.27		FHACB162V333 J1LHZO	HACB3C333J		
	0.039		15.1	14.4			4.64		FHACB162V393 J1LHZO	HACB3C393J		
	0.047	27.7	16.4	15.6	22.5		5.09		FHACB162V473 J1LHZO	HACB3C473J		
	0.056		17.6	16.8			5.56		FHACB162V563 J1LHZO	HACB3C563J		
	0.068		19.1	18.2			6.12		FHACB162V683 J1LHZO	HACB3C683J		
	0.082		17.4	16.6			5.29		FHACB162V823 J2LEZO	HACB3C823J		
	0.1		19.0	18.1			5.84		FHACB162V104 J2LEZO	HACB3C104J		
	0.12		20.6	19.6			6.40		FHACB162V124 J2LEZO	HACB3C124J		
	0.15	22.8	21.8	7.15	FHACB162V154 J2LEZO		HACB3C154J					
	0.18	24.7	23.6	7.84	FHACB162V184 J2LEZO		HACB3C184J					
	0.22	27.2	25.9	8.66	FHACB162V224 J2LEZO		HACB3C224J					
	0.27	42.7	23.4	22.3	37.5		6.47		FHACB162V274 J4LJZO	HACB3C274J		
	0.33		25.9	24.7			7.15		FHACB162V334 J4LJZO	HACB3C334J		
	0.39		27.9	26.6			7.77		FHACB162V394 J4LJZO	HACB3C394J		

- (1) Capacitance tolerance: Standard(J: ±5%) , Option(H: ±3%)
- (2) The maximum ripple current : +85°C max., 100kHz, sine wave
- (3) WV(Vac) : 50Hz or 60Hz, sine wave

◆STANDARD RATINGS

WV (Vdc)	Cap (μF)	Dimensions (mm)					Maximum ripple current (Arms)	WV (Vac)	Part Number	Previous Part Number (Just for your reference)
		W	H	T	F	φd				
2000	0.001	19.7	8.3	8.1	15.0	0.8	0.28	450	FHACB202V102JKLDZ0	HACB3D102J
	0.0012		9.0	8.6			0.34		FHACB202V122JKLDZ0	HACB3D122J
	0.0015		9.6	9.2			0.42		FHACB202V152JKLDZ0	HACB3D152J
	0.0018		9.3	9.0			0.51		FHACB202V182JKLDZ0	HACB3D182J
	0.0022		10.0	9.6			0.62		FHACB202V222JKLDZ0	HACB3D222J
	0.0027		8.5	8.2			0.76		FHACB202V272JKLDZ0	HACB3D272J
	0.0033		9.1	8.7			0.93		FHACB202V332JKLDZ0	HACB3D332J
	0.0039		9.6	9.2			1.10		FHACB202V392JKLDZ0	HACB3D392J
	0.0047		10.2	9.8			1.33		FHACB202V472JKLDZ0	HACB3D472J
	0.0056		11.0	10.5			1.53		FHACB202V562JKLDZ0	HACB3D562J
	0.0068		11.8	11.3			1.92		FHACB202V682JKLDZ0	HACB3D682J
	0.0082		12.7	12.1			2.32		FHACB202V822JKLDZ0	HACB3D822J
	0.01		13.7	13.1			2.83		FHACB202V103JKLDZ0	HACB3D103J
	0.012		14.8	14.1			3.39		FHACB202V123JKLDZ0	HACB3D123J
	0.015	16.3	15.5	4.24	FHACB202V153JKLDZ0	HACB3D153J				
	0.018	13.2	12.6	3.52	FHACB202V183J1LHZ0	HACB3D183J				
	0.022	14.3	13.6	3.89	FHACB202V223J1LHZ0	HACB3D223J				
	0.027	15.5	14.8	4.31	FHACB202V273J1LHZ0	HACB3D273J				
	0.033	17.0	16.2	4.77	FHACB202V333J1LHZ0	HACB3D333J				
	0.039	18.3	17.4	5.19	FHACB202V393J1LHZ0	HACB3D393J				
	0.047	19.8	18.8	5.69	FHACB202V473J1LHZ0	HACB3D473J				
	0.056	17.9	17.0	4.89	FHACB202V563J2LEZ0	HACB3D563J				
	0.068	19.4	18.5	5.39	FHACB202V683J2LEZ0	HACB3D683J				
	0.082	21.2	20.2	5.91	FHACB202V823J2LEZ0	HACB3D823J				
	0.1	23.2	22.1	6.53	FHACB202V104J2LEZ0	HACB3D104J				
	0.12	25.3	24.1	7.15	FHACB202V124J2LEZ0	HACB3D124J				
	0.15	27.9	26.6	8.00	FHACB202V154J2LEZ0	HACB3D154J				
	0.18	22.1	21.1	5.67	FHACB202V184J4LJZ0	HACB3D184J				
0.22	24.5	23.4	6.27	FHACB202V224J4LJZ0	HACB3D224J					
0.27	26.5	25.3	6.95	FHACB202V274J4LJZ0	HACB3D274J					

- (1)Capacitance tolerance:Standard (J:±5%),Option (H:±3%)
 (2)The maximum ripple current : +85°C max., 100kHz, sine wave
 (3)WV(Vac) : 50Hz or 60Hz, sine wave

WV (Vdc)	Cap (μF)	Dimensions (mm)					Maximum ripple current (Arms)	WV (Vac)	Part Number	Previous Part Number (Just for your reference)					
		W	H	T	F	φd									
3150	0.0047	34.7	12.0	11.5	30.0	1.0	2.60	920	FHACB3B2V472JLLQZ0	HACB3F472J					
	0.0056		12.9	12.3			2.84		FHACB3B2V562JLLQZ0	HACB3F562J					
	0.0068		13.9	13.3			3.13		FHACB3B2V682JLLQZ0	HACB3F682J					
	0.0082		15.0	14.3			3.44		FHACB3B2V822JLLQZ0	HACB3F822J					
	0.01		16.3	15.5			3.80		FHACB3B2V103JLLQZ0	HACB3F103J					
	0.012		17.5	16.7			4.16		FHACB3B2V123JLLQZ0	HACB3F123J					
	0.015		19.3	18.4			4.65		FHACB3B2V153JLLQZ0	HACB3F153J					
	0.018		20.9	19.9			5.09		FHACB3B2V183JLLQZ0	HACB3F183J					
	0.022		22.9	21.9			5.63		FHACB3B2V223JLLQZ0	HACB3F223J					
	0.027		25.2	24.0			6.24		FHACB3B2V273JLLQZ0	HACB3F273J					
	0.033		27.5	26.2			6.90		FHACB3B2V333JLLQZ0	HACB3F333J					
	4000		0.0027	34.7			12.7		12.1	30.0	1.0	1.56	920	FHACB402V272JLLQZ0	HACB3G272J
			0.0033				13.7		13.1			1.91		FHACB402V332JLLQZ0	HACB3G332J
0.0039		14.6	13.9		2.25	FHACB402V392JLLQZ0	HACB3G392J								
0.0047		15.7	15.0		2.72	FHACB402V472JLLQZ0	HACB3G472J								
0.0056		17.0	16.2		3.24	FHACB402V562JLLQZ0	HACB3G562J								
0.0068		18.4	17.5		3.71	FHACB402V682JLLQZ0	HACB3G682J								
0.0082		20.0	19.0		4.07	FHACB402V822JLLQZ0	HACB3G822J								
0.01		21.8	20.7		4.49	FHACB402V103JLLQZ0	HACB3G103J								
0.012		23.7	22.6		4.92	FHACB402V123JLLQZ0	HACB3G123J								
0.015		26.2	25.0		5.50	FHACB402V153JLLQZ0	HACB3G153J								
0.018		28.5	27.1		6.03	FHACB402V183JLLQZ0	HACB3G183J								

- (1)Capacitance tolerance : Standard (J:±5%) , Option (K:±10%)
 (2)The maximum ripple current : +85°C max., 100kHz, sine wave
 (3)WV(Vac) : 50Hz or 60Hz, sine wave

◆DIMENSIONS (mm)

