

DLCAP™ DXE series



- 電力貯蔵・バッテリーアシスト・短時間バックアップ等に最適。
- 車載用途(回生エネルギー、ピーク電力アシスト)にも最適。
- 横置き設置が可能
  - ・ Suitable for electricity storage, battery assistance, short-term backups, etc.
  - ・ Also suitable for kinetic energy recapturing, start/stop application for automobile.
  - ・ Can be installed horizontally.

◆規格表 / SPECIFICATIONS

項目 / Items	性能 / Specifications	
カテゴリ温度範囲 / Operating Temperature	-40°C ~ +70°C	
静電容量許容差 / Capacitance Tolerance	±10% (K) (20°C)	
温度特性 / Temperature Characteristics	容量変化率 Capacitance Change	20°Cの値の±30%以内 ≤±30% of the measured value at 20°C
	内部抵抗変化率 Internal Resistance Change	「製品一覧表」に示す内部抵抗最大値の1200%以下 ≤1200% of the internal resistance maximum value given in the ratings tables (-40°C)
高温度負荷特性 / Load Life Test	70°Cにおいて定格電圧を2000時間印加後、20°Cに復帰させ測定を行ったとき、下記を満足すること After the capacitors are subjected to the rated DC voltage at 70°C for 2000 hours, the following specifications shall be satisfied when they are restored to 20°C.	
	容量変化率 Capacitance Change	初期値 (20°C) の±30%以内 ≤±30% of the initial measured value at 20°C
	内部抵抗変化率 Internal Resistance Change	「製品一覧表」に示す内部抵抗最大値の300%以下 ≤300% of the internal resistance maximum value given in the ratings tables
耐湿性能 / Bias Humidity Test	60°C、90~95%RH、無負荷500時間放置後、20°Cに復帰させ測定を行ったとき、下記を満足すること After the capacitors are left at 60°C and 90 to 95%RH for 500 hours without voltage applied, the following specifications shall be satisfied when they are restored to 20°C.	
	容量変化率 Capacitance Change	初期値 (20°C) の±30%以内 ≤±30% of the initial measured value at 20°C
	内部抵抗変化率 Internal Resistance Change	「製品一覧表」に示す内部抵抗最大値の300%以下 ≤300% of the internal resistance maximum value given in the ratings tables

◆製品一覧表 / STANDARD RATINGS

● DXE series

Rated Voltage [V]	Capacitance		Nominal Case Size		Internal Resistance		Weight*1 [g]	Energy Storage*2 [Wh]	Part No.
	Typ. (rated) [F]	Min. [F]	φ D [mm]	L [mm]	Typ. [mΩ]	Max. [mΩ]			
2.5	400	360	40	65	2.1	2.5	120	0.4	DDXE2R5LGN401KB65S
	800	720		105	1.1	1.3	200	0.7	DDXE2R5LGN801KBA5S
	1200	1080		150	0.8	1.0	280	1.1	DDXE2R5LGN122KBF0S
	1400	1260		150	1.1	1.3	280	1.3	DDXE2R5LGN142KBF0S
Rated Voltage [V]	Capacitance		Nominal Case Size		Internal Resistance		Weight*1 [g]	Energy Storage*2 [Wh]	Part No.
	Typ. (rated) [F]	Min. [F]	φ D [mm]	L [mm]	Typ. [mΩ]	Max. [mΩ]			
2.5	400	360	40	65	2.1	2.5	120	0.4	DDXE2R5LGL401KB65S*3
	1400	1260		150	1.1	1.3	280	1.3	DDXE2R5LGL142KBF0S*3

\*1: 参考値/Reference data

\*2: 本品に記載される貯蔵エネルギー量 [Wh] は、JEITA で発行されている「電気及び電子機器用電気二重層キャパシタの輸送に関する手引書」(日本語のみ)に基づいて算出しています。

Energy Storage (Wh) written on this module is calculated based on 「電気及び電子機器用電気二重層キャパシタの輸送に関する手引書」(Japanese only) by JEITA.

\*3: 横置き設置対応品/Possible to used horizontally

◆品番体系 / PART NUMBERING SYSTEM

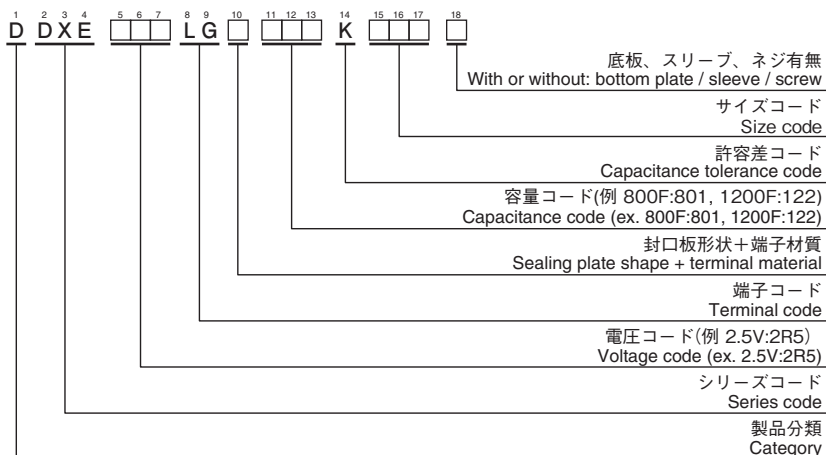

# DLCAP™ DXE series

## ◆寸法図 / DIMENSIONS [mm]

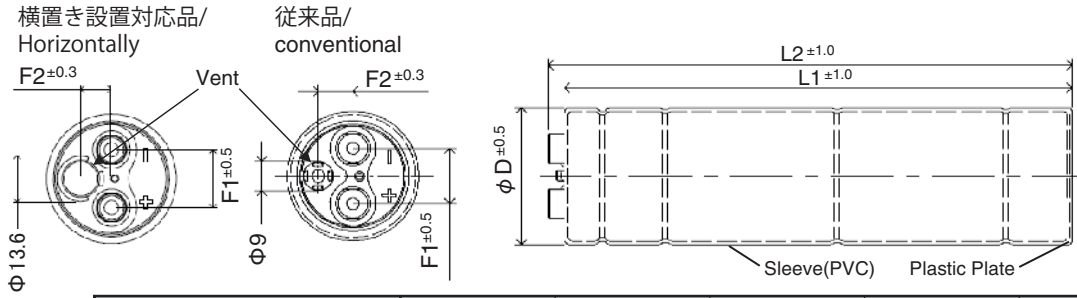

Part No.	φ D [mm]	L 1 [mm]	L 2 [mm]	F 1 [mm]	F 2 [mm]
DDXE2R5LGN401KB65S	40.4	66	71	17.0	10.5
DDXE2R5LGN801KBA5S		106	111		
DDXE2R5LGN122KBF0S		151	156		
DDXE2R5LGN142KBF0S		151	156		
Part No.	φ D [mm]	L 1 [mm]	L 2 [mm]	F 1 [mm]	F 2 [mm]
DDXE2R5LGL401KB65S	40.4	66	71	17.0	9.0
DDXE2R5LGL142KBF0S		151	156		

Detailed dimensions of the terminal

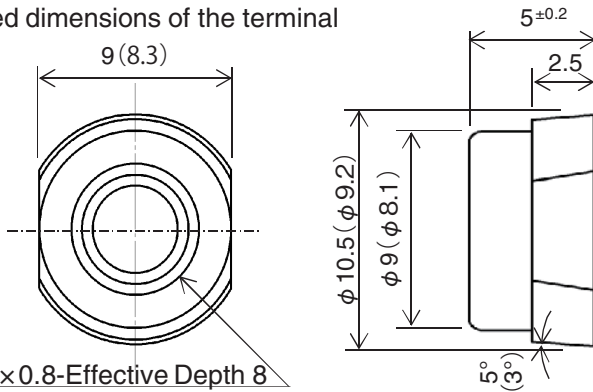

( )は横置き設置対応品の寸法  
( ) is the size of the corresponding product placed horizontally.

<端子ネジ規格 / Screw specification>  
プラス六角ボルトネジ : M5×0.8×10  
Plus hexagon-headed screw : M5×0.8×10

ネジ締付最大許容トルク : 3.23Nm  
Maximum screw tightening torque : 3.23Nm

## ◆容量と内部抵抗の温度特性 / Temperature Characteristics of Capacitance & DCIR

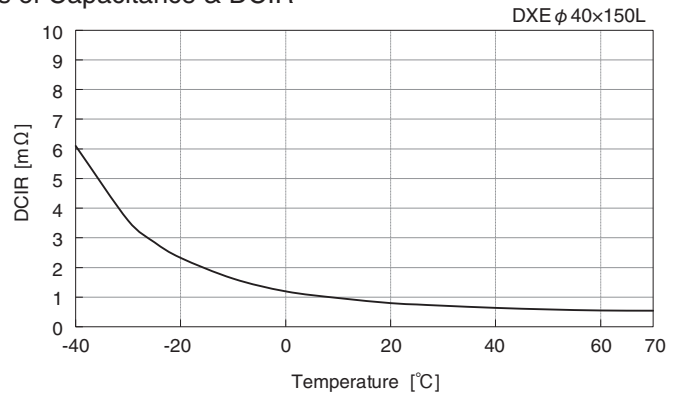
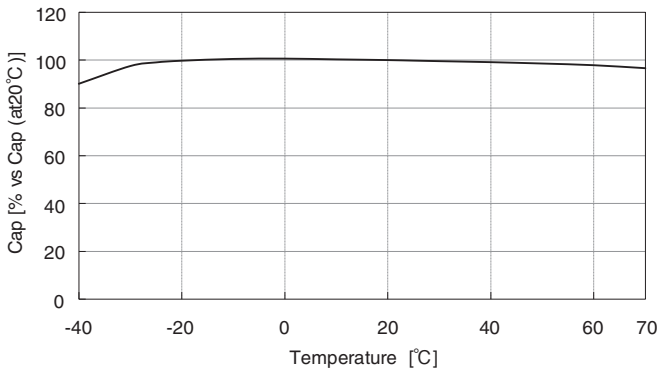

## ◆70°C高温負荷試験 / 70°C Load Life Test

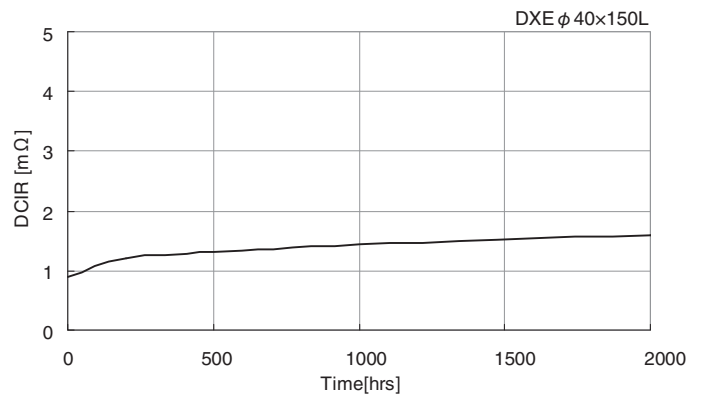
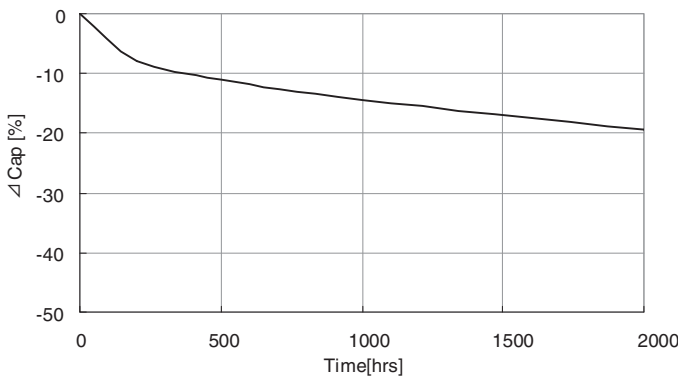

記載内容は予告なく変更する場合があります。ご購入、ご使用の際は当社の納入仕様書をご要求下さい。本カタログと納入仕様書の記載内容に基づいてご使用下さい。  
Product specifications in this catalog are subject to change without notice. Request our product specifications before purchase and/or use. Please use our products based on the information contained in this catalog and product specifications.