

◆FEATURES

- Large surge capability (the surge current ratings of TNR V series, by 8/20 μs, are about two times larger than TNR G series).
- Large energy capability (1.5 time larger than TNR G series).
- One rank smaller TNR V has same peak current as TNR G.
- Excellent voltage non-linear coefficient.
Low clamping voltage.
- Symmetrical V-I characteristics (No polarity).
- Fast response.
- Stable characteristics against repeated surges.
- Superior temperature characteristics.
- High reliability
- UL, CSA and VDE recognized components
UL 1449 3rd File : E323623
UL 1414 File : E65426 (Except "12V")
CSA File : LR97864
VDE File : 118623

◆APPLICATIONS

- Protection for semiconductors from over voltage.
- Protection for electronic instruments from lightning surges.
- Absorption of on-off surges from motors and relays.

Operating Temperature Range: -40 to +85°C
Storage Temperature Range: -50 to +125°C

◆PART NUMBERING SYSTEM

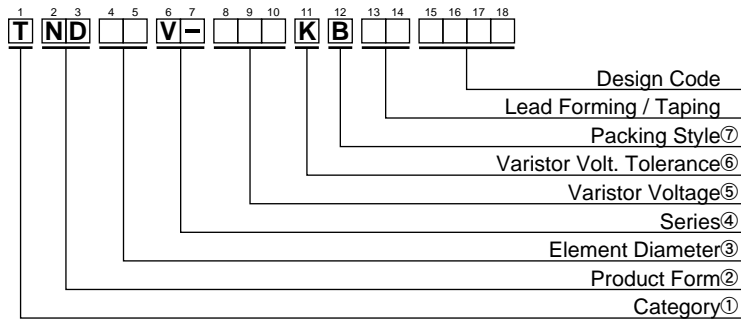

①Category	
T	Metal Oxide Varistors TNR

②Product Form	
ND	Disk Type

③Element Diameter	
05	φ 5 mm
07	φ 7 mm
09	φ 9 mm
10	φ10 mm
12	φ12 mm
14	φ14 mm
20	φ20 mm

④Series	
V-	V Series

⑤Varistor Voltage	
The first two digits are significant figures and the third one denotes the number of following zeros.	

⑥Varistor Volt. Tolerance	
K	±10%

⑦Packing Style	
B	Bulk
T	Taping



V Series

◆STANDARD RATINGS (Type 5V)

Part Number	Previous Part Number (Just for your reference)	Maximum Ratings					Max. Clamping Voltage		Capacitance Typical @1kHz (pF)	Varistor Voltage V _{0.1mA} (V)	T Max. (mm)
		Max. Allowable Voltage		Max. Peak Current	Max. Energy	Rated Wattage	(A)	(V)			
		AC (Vrms)	DC (V)	8/20μs(A)	2ms(J)	(W)					
TND05V-180KB00AAA0	TNR5V180K	11	14	250A/1 time 125A/2 times	0.4	0.01	1	40	2,540	18 (16~ 20)	4.5
TND05V-220KB00AAA0	TNR5V220K	14	18		0.5			48	2,090	22 (20~ 24)	
TND05V-270KB00AAA0	TNR5V270K	17	22		0.7			60	1,790	27 (24~ 30)	
TND05V-330KB00AAA0	TNR5V330K	20	26		0.8			73	1,480	33 (30~ 36)	
TND05V-390KB00AAA0	TNR5V390K	25	30		0.9			86	1,310	39 (35~ 43)	
TND05V-470KB00AAA0	TNR5V470K	30	37		1.1			104	1,140	47 (42~ 52)	
TND05V-560KB00AAA0	TNR5V560K	35	44		1.3			123	1,000	56 (50~ 62)	
TND05V-680KB00AAA0	TNR5V680K	40	55	1.6	150	870	68 (61~ 75)				
TND05V-820KB00AAA0	TNR5V820K	50	65	800A/1 time 600A/2 times	2.5	0.1	5	145	400	82 (74~ 90)	4.1
TND05V-101KB00AAA0	TNR5V101K	60	85		3			175	350	100 (90~110)	4.3
TND05V-121KB00AAA0	TNR5V121K	75	100		3.5			210	310	120 (108~132)	4.5
TND05V-151KB00AAA0	TNR5V151K	95	125		4.5			260	270	150 (135~165)	4.8
TND05V-181KB00AAA0	TNR5V181K	110	145		5			325	190	180 (162~198)	4.3
TND05V-201KB00AAA0	TNR5V201K	130	170		6			355	110	200 (185~225)	4.4
TND05V-221KB00AAA0	TNR5V221K	140	180		6.5			380	110	220 (198~242)	4.5
TND05V-241KB00AAA0	TNR5V241K	150	200		7.5			415	100	240 (216~264)	4.6
TND05V-271KB00AAA0	TNR5V271K	175	225		8			475	90	270 (247~303)	4.8
TND05V-331KB00AAA0	TNR5V331K	210	270		9.5			570	80	330 (297~363)	5.1
TND05V-361KB00AAA0	TNR5V361K	230	300		11			620	80	360 (324~396)	5.3
TND05V-391KB00AAA0	TNR5V391K	250	320		12			675	70	390 (351~429)	5.4
TND05V-431KB00AAA0	TNR5V431K	275	350		13.5			745	70	430 (387~473)	5.6
TND05V-471KB00AAA0	TNR5V471K	300	385		15			810	60	470 (423~517)	5.8

◆DIMENSIONS [mm]

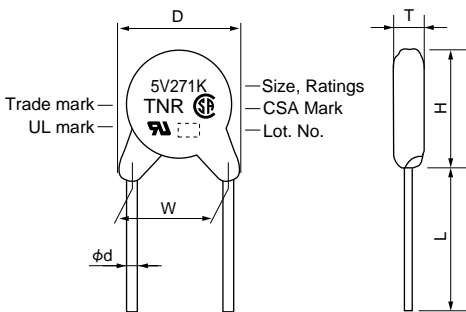

D Max.	H Max.	T Max.	L Min.	φd ±0.05	W ±1.0
7.5	10.0	Ref. to RATINGS	20.0	0.6	5.0

◆V-I CURVE

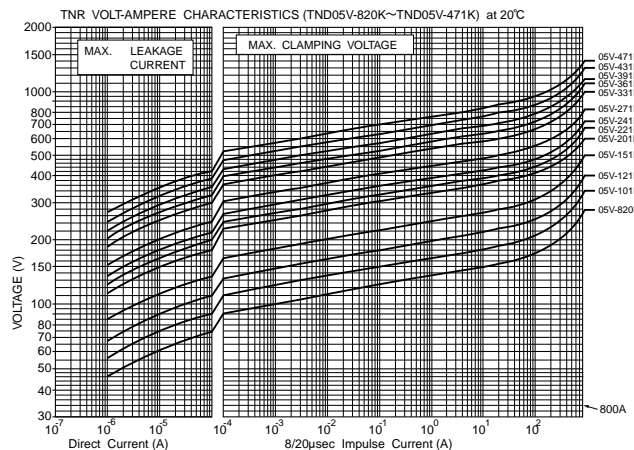
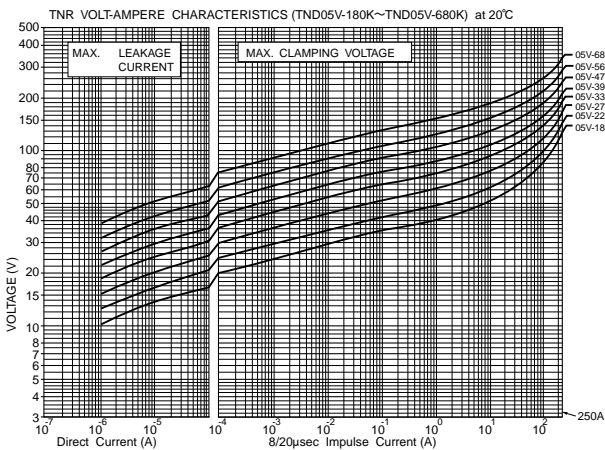



V Series

◆STANDARD RATINGS (Type 7V)

Part Number	Previous Part Number (Just for your reference)	Maximum Ratings					Max. Clamping Voltage		Capacitance Typical @1kHz (pF)	Varistor Voltage V1mA (V)	T Max. (mm)
		Max. Allowable Voltage		Max. Peak Current	Max. Energy	Rated Wattage	(A)	(V)			
		AC (Vrms)	DC (V)	8/20μs(A)	2ms(J)						
TND07V-150KB00AAA0	TNR7V150K	8	12	500A/1 time	0.7	0.02	2.5	30	4,600	15 (13~ 17)	4.5
TND07V-180KB00AAA0	TNR7V180K	11	14		0.9			36	3,800	18 (16~ 20)	4.5
TND07V-220KB00AAA0	TNR7V220K	14	18		1.1			43	3,200	22 (20~ 24)	4.6
TND07V-270KB00AAA0	TNR7V270K	17	22		1.3			53	2,800	27 (24~ 30)	4.7
TND07V-330KB00AAA0	TNR7V330K	20	26	250A/2 times	1.6	0.02	2.5	65	2,300	33 (30~ 36)	4.9
TND07V-390KB00AAA0	TNR7V390K	25	30		1.9			77	2,100	39 (35~ 43)	4.8
TND07V-470KB00AAA0	TNR7V470K	30	37		2.3			93	1,900	47 (42~ 52)	4.9
TND07V-560KB00AAA0	TNR7V560K	35	44		2.7			110	1,700	56 (50~ 62)	5.0
TND07V-680KB00AAA0	TNR7V680K	40	55	3.3	135	1,500	68 (61~ 75)	5.2			
TND07V-820KB00AAA0	TNR7V820K	50	65	1,750A/1 time	5	0.25	10	135	800	82 (74~ 90)	4.1
TND07V-101KB00AAA0	TNR7V101K	60	85		6			165	700	100 (90~110)	4.3
TND07V-121KB00AAA0	TNR7V121K	75	100		7			200	650	120 (108~132)	4.5
TND07V-151KB00AAA0	TNR7V151K	95	125		9			250	600	150 (135~165)	4.8
TND07V-181KB00AAA0	TNR7V181K	110	145	1,250A/2 times	11	0.25	10	300	430	180 (162~198)	4.3
TND07V-201KB00AAA0	TNR7V201K	130	170		12.5			340	250	200 (185~225)	4.4
TND07V-221KB00AAA0	TNR7V221K	140	180		13.5			360	230	220 (198~242)	4.5
TND07V-241KB00AAA0	TNR7V241K	150	200		15			395	210	240 (216~264)	4.6
TND07V-271KB00AAA0	TNR7V271K	175	225	17	455	190	270 (247~303)	4.8			
TND07V-331KB00AAA0	TNR7V331K	210	270	20	545	160	330 (297~363)	5.1			
TND07V-361KB00AAA0	TNR7V361K	230	300	23	595	150	360 (324~396)	5.3			
TND07V-391KB00AAA0	TNR7V391K	250	320	25	650	140	390 (351~429)	5.4			
TND07V-431KB00AAA0	TNR7V431K	275	350	27.5	710	130	430 (387~473)	5.6			
TND07V-471KB00AAA0	TNR7V471K	300	385	30	775	120	470 (423~517)	5.8			
TND07V-511KB00AAA0	TNR7V511K	320	410	32	845	110	510 (459~561)	6.0			

◆DIMENSIONS [mm]

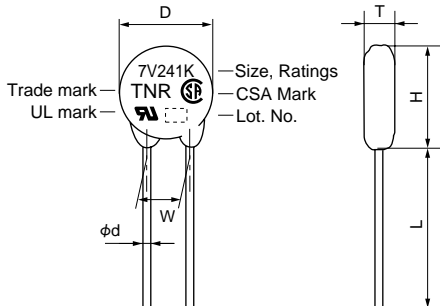

D Max.	H Max.	T Max.	L Min.	φd ±0.05	W ±1.0
8.5	11.5	Ref. to RATINGS	20.0	0.6	5.0

◆V-I CURVE (Type 7V)

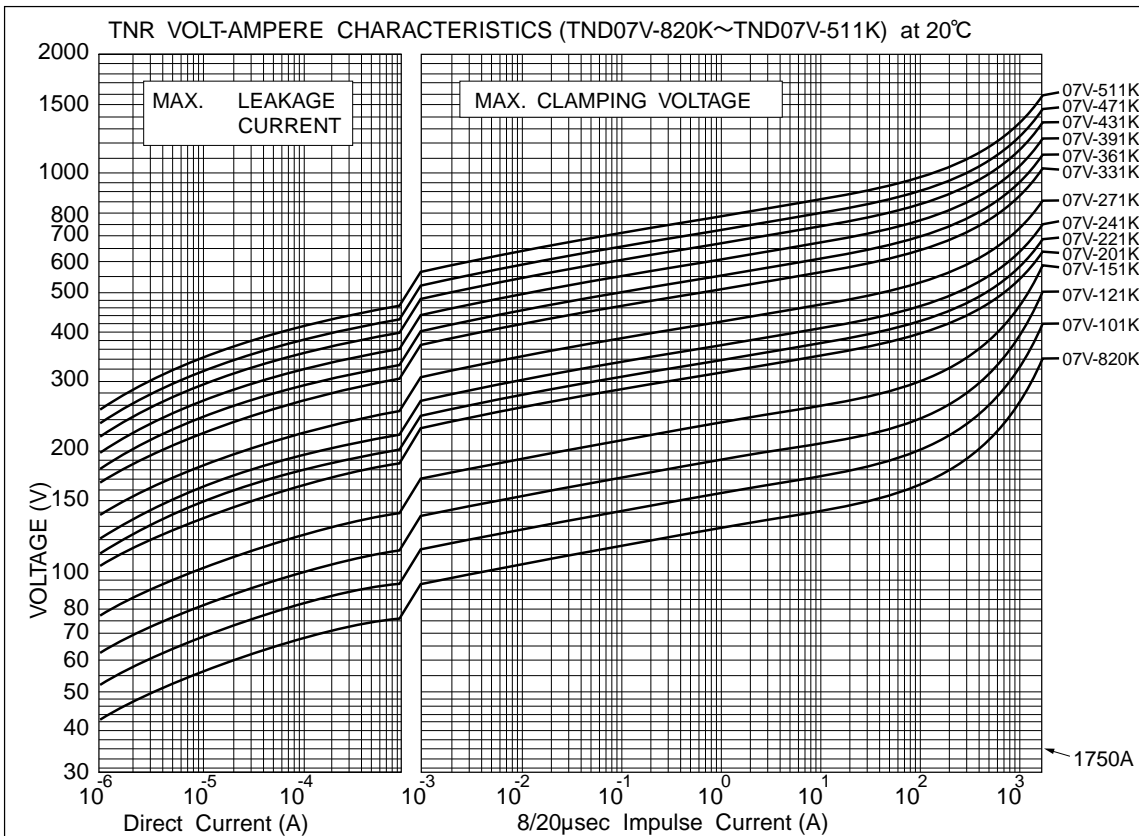
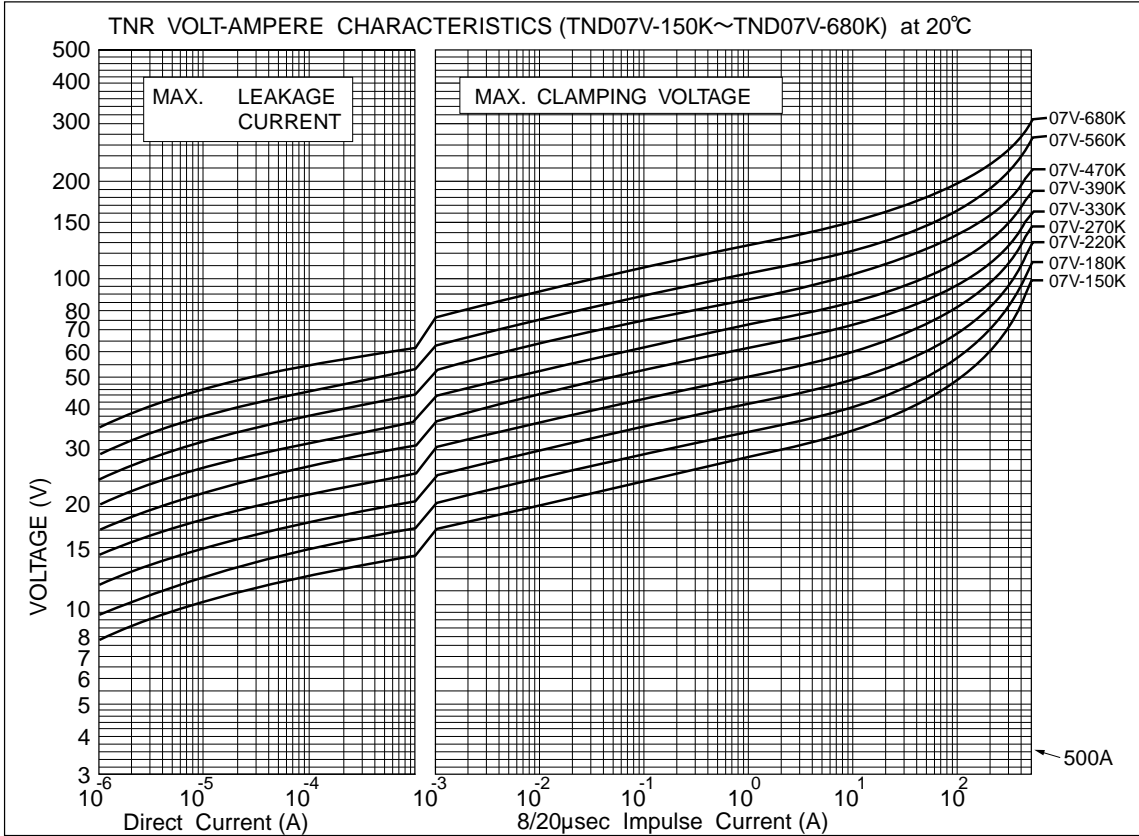



V Series

◆ RATINGS (Type 9V)

Part Number	Previous Part Number (Just for your reference)	Maximum Ratings					Max. Clamping Voltage		Capacitance Typical @1kHz (pF)	Varistor Voltage V _{1mA} (V)	T Max. (mm)	
		Max. Allowable Voltage		Max. Peak Current	Max. Energy	Rated Wattage	(A)	(V)				
		AC (Vrms)	DC (V)	8/20μs(A)	2ms(J)							(W)
TND09V-150KB00AAA0	TNR9V150K	8	12	800A/1 time	2.0	0.02	5	30	9,600	15 (13~ 17)	3.8	
TND09V-180KB00AAA0	TNR9V180K	11	14		2.2			36	8,000	18 (16~ 20)	3.8	
TND09V-220KB00AAA0	TNR9V220K	14	18		2.6			43	7,000	22 (20~ 24)	4.0	
TND09V-270KB00AAA0	TNR9V270K	17	22		3.2			53	6,000	27 (24~ 30)	4.2	
TND09V-330KB00AAA0	TNR9V330K	20	26	400A/2 times	4.0	0.25	25	65	5,000	33 (30~ 36)	4.5	
TND09V-390KB00AAA0	TNR9V390K	25	30		4.7			77	4,500	39 (35~ 43)	4.0	
TND09V-470KB00AAA0	TNR9V470K	30	37		5.6			93	4,000	47 (42~ 52)	4.2	
TND09V-560KB00AAA0	TNR9V560K	35	44		6.7			110	3,500	56 (50~ 62)	4.4	
TND09V-680KB00AAA0	TNR9V680K	40	55	8.2	135	3,200	68 (61~ 75)	4.5				
TND09V-820KB00AAA0	TNR9V820K	50	65	10	135	1,700	82 (74~ 90)	3.8				
TND09V-101KB00AAA0	TNR9V101K	60	85	12	165	1,600	100 (90~110)	3.9				
TND09V-121KB00AAA0	TNR9V121K	75	100	14.5	200	1,400	120 (108~132)	4.1				
TND09V-151KB00AAA0	TNR9V151K	95	125	18	250	1,300	150 (135~165)	4.4				
TND09V-181KB00AAA0	TNR9V181K	110	145	22	300	900	180 (162~198)	4.0				
TND09V-201KB00AAA0	TNR9V201K	130	170	25	340	500	200 (185~225)	4.1				
TND09V-221KB00AAA0	TNR9V221K	140	180	3,000A/1 time	27.5	0.25	25	360	450	220 (198~242)	4.2	
TND09V-241KB00AAA0	TNR9V241K	150	200		30			395	400	240 (216~264)	4.3	
TND09V-271KB00AAA0	TNR9V271K	175	225		2,000A/2 times			35	455	350	270 (247~303)	4.5
TND09V-331KB00AAA0	TNR9V331K	210	270					42	545	300	330 (297~363)	4.8
TND09V-361KB00AAA0	TNR9V361K	230	300	45	595	280	360 (324~396)	5.0				
TND09V-391KB00AAA0	TNR9V391K	250	320	50	650	260	390 (351~429)	5.1				
TND09V-431KB00AAA0	TNR9V431K	275	350	55	710	240	430 (387~473)	5.3				
TND09V-471KB00AAA0	TNR9V471K	300	385	60	775	220	470 (423~517)	5.6				
TND09V-511KB00AAA0	TNR9V511K	320	410	67	845	210	510 (459~561)	5.8				

◆ DIMENSIONS [mm]

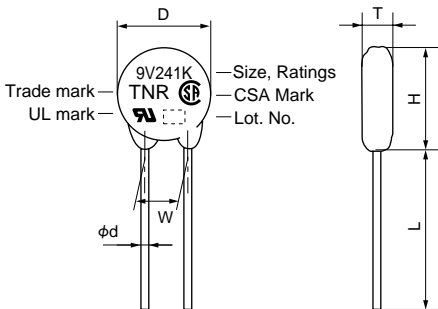

D Max.	H Max.	T Max.	L Min.	φd ±0.05	W ±1.0
11.5	14.5	Ref. to RATINGS	20.0	0.6	5.0



V Series

◆V-I CURVE (Type 9V)

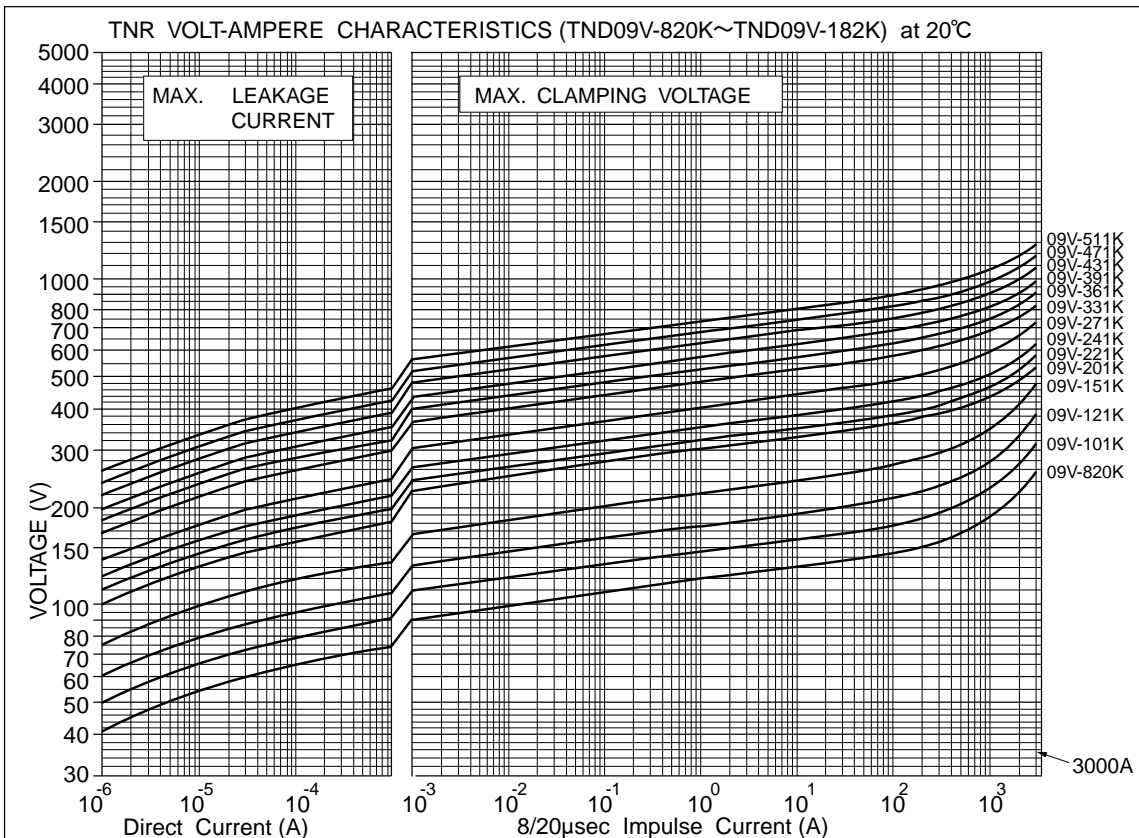
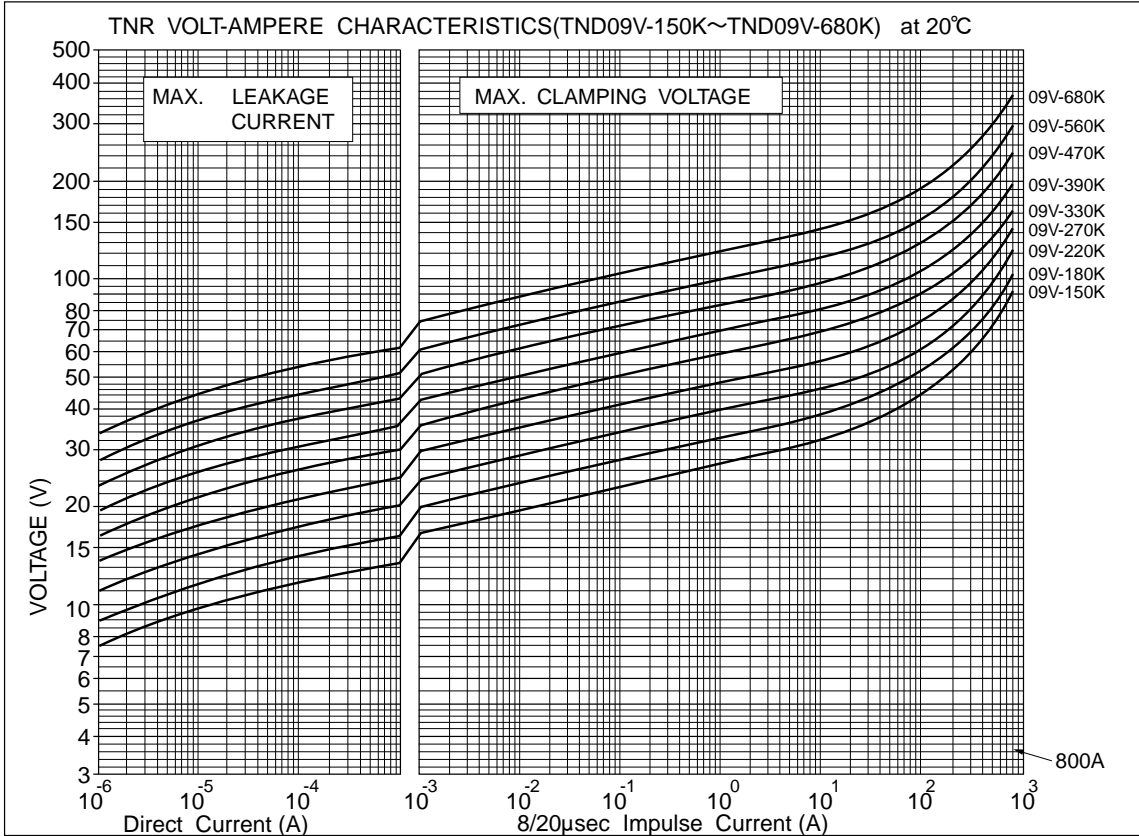

◆RATINGS (Type 10V)

Part Number	Previous Part Number (Just for your reference)	Maximum Ratings					Max. Clamping Voltage	Capacitance Typical @1kHz	Varistor Voltage V _{1mA}	T Max.	E ±1.0	W ₂ reference	
		Max. Allowable Voltage		Max. Peak Current	Max. Energy	Rated Wattage							
		AC (Vrms)	DC (V)	8/20μs(A)	2ms(J)	(W)							
TND10V-150KB00AAA0	TNR10V150K	8	12	1,000A/1 time	2.0	0.05	5	30	9,600	15 (13~ 17)	4.5	1.0	7.6
TND10V-180KB00AAA0	TNR10V180K	11	14		2.2			36	8,000	18 (16~ 20)	4.6	1.1	7.6
TND10V-220KB00AAA0	TNR10V220K	14	18		2.6			43	7,000	22 (20~ 24)	4.7	1.2	7.6
TND10V-270KB00AAA0	TNR10V270K	17	22		3.2			53	6,000	27 (24~ 30)	4.8	1.3	7.6
TND10V-330KB00AAA0	TNR10V330K	20	26	500A/2 times	4.0	0.05	5	65	5,000	33 (30~ 36)	5.0	1.5	7.6
TND10V-390KB00AAA0	TNR10V390K	25	30		4.7			77	4,500	39 (35~ 43)	4.9	1.3	7.6
TND10V-470KB00AAA0	TNR10V470K	30	37		5.6			93	4,000	47 (42~ 52)	5.0	1.4	7.6
TND10V-560KB00AAA0	TNR10V560K	35	44		6.7			110	3,500	56 (50~ 62)	5.1	1.6	7.7
TND10V-680KB00AAA0	TNR10V680K	40	55	8.2	135	3,200	68 (61~ 75)	5.3	1.8	7.7			
TND10V-820KB00AAA0	TNR10V820K	50	65	3,500A/1 time	10	0.4	25	135	1,700	82 (74~ 90)	4.5	1.1	7.6
TND10V-101KB00AAA0	TNR10V101K	60	85		12			165	1,600	100 (90~ 110)	4.7	1.3	7.6
TND10V-121KB00AAA0	TNR10V121K	75	100		14.5			200	1,400	120 (108~ 132)	4.9	1.4	7.6
TND10V-151KB00AAA0	TNR10V151K	95	125		18			250	1,300	150 (135~ 165)	5.2	1.7	7.7
TND10V-181KB00AAA0	TNR10V181K	110	145	2,500A/2 times	22	0.4	25	300	900	180 (162~ 198)	4.7	1.1	7.6
TND10V-201KB00AAA0	TNR10V201K	130	170		25			340	500	200 (185~ 225)	4.8	1.2	7.6
TND10V-221KB00AAA0	TNR10V221K	140	180		27.5			360	450	220 (198~ 242)	4.9	1.3	7.6
TND10V-241KB00AAA0	TNR10V241K	150	200		30			395	400	240 (216~ 264)	5.0	1.3	7.6
TND10V-271KB00AAA0	TNR10V271K	175	225	3,500A/1 time	35	0.4	25	455	350	270 (247~ 303)	5.2	1.4	7.6
TND10V-331KB00AAA0	TNR10V331K	210	270		42			545	300	330 (297~ 363)	5.5	1.6	7.7
TND10V-361KB00AAA0	TNR10V361K	230	300		45			595	280	360 (324~ 396)	5.7	1.8	7.7
TND10V-391KB00AAA0	TNR10V391K	250	320		50			650	260	390 (351~ 429)	5.8	1.9	7.7
TND10V-431KB00AAA0	TNR10V431K	275	350	2,500A/2 times	55	0.4	25	710	240	430 (387~ 473)	6.0	2.0	7.8
TND10V-471KB00AAA0	TNR10V471K	300	385		60			775	220	470 (423~ 517)	6.2	2.1	7.8
TND10V-511KB00AAA0	TNR10V511K	320	410		67			845	210	510 (459~ 561)	6.4	2.3	7.8
TND10V-561KB00AAA0	TNR10V561K	350	460		67			922	195	560 (504~ 616)	6.7	2.5	7.9
TND10V-621KB00AAA0	TNR10V621K	385	505	3,500A/1 time	67	0.4	25	1,025	180	620 (558~ 682)	7.1	2.7	8.0
TND10V-681KB00AAA0	TNR10V681K	420	560		67			1,120	165	680 (612~ 748)	7.4	2.9	8.0
TND10V-751KB00AAA0	TNR10V751K	460	615		70			1,240	150	750 (675~ 825)	7.8	3.1	8.1
TND10V-821KB00AAA0	TNR10V821K	510	670		80			1,355	140	820 (738~ 902)	8.1	3.4	8.2
TND10V-911KB00AAA0	TNR10V911K	550	745	2,500A/2 times	90	0.4	25	1,500	125	910 (819~1,001)	8.6	3.7	8.4
TND10V-102KB00AAA0	TNR10V102K	625	825		100			1,650	115	1,000 (900~1,100)	9.1	4.0	8.5
TND10V-112KB00AAA0	TNR10V112K	680	895		110			1,815	105	1,100 (990~1,210)	9.7	4.4	8.7
TND10V-122KB00AAA0	TNR10V122K	720	980		120			1,950	95	1,200 (1,080~1,320)	10.5	4.7*	8.9**
TND10V-152KB00AAA0	TNR10V152K	860	1,220	3,500A/1 time	150	0.4	25	2,440	85	1,500 (1,350~1,650)	12.4	5.8*	9.5**
TND10V-182KB00AAA0	TNR10V182K	1,000	1,465		183			2,970	70	1,800 (1,700~1,980)	14.4	6.9*	10.2**

*E±2 **W₂±2

◆DIMENSIONS [mm]

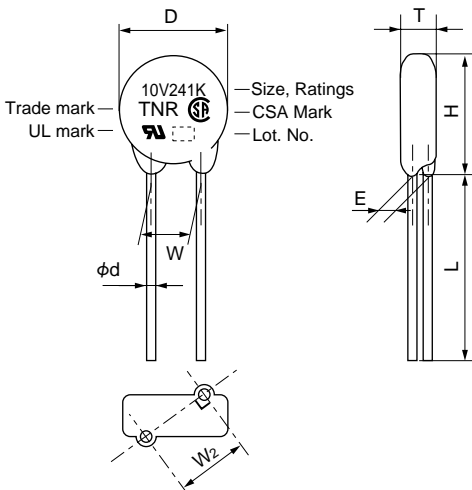

Part Number	D Max.	H Max.	T Max.	L Min.	φd ±0.05	W ±1.0
TND10V-150K to TND10V-511K	11.5	14.5	Ref. to RATINGS	20.0	0.8	7.5
TND10V-561K to TND10V-112K	12.5	15.5				
TND10V-122K to TND10V-182K	13.5	16.5				



V Series

◆V-I CURVE (Type 10V)

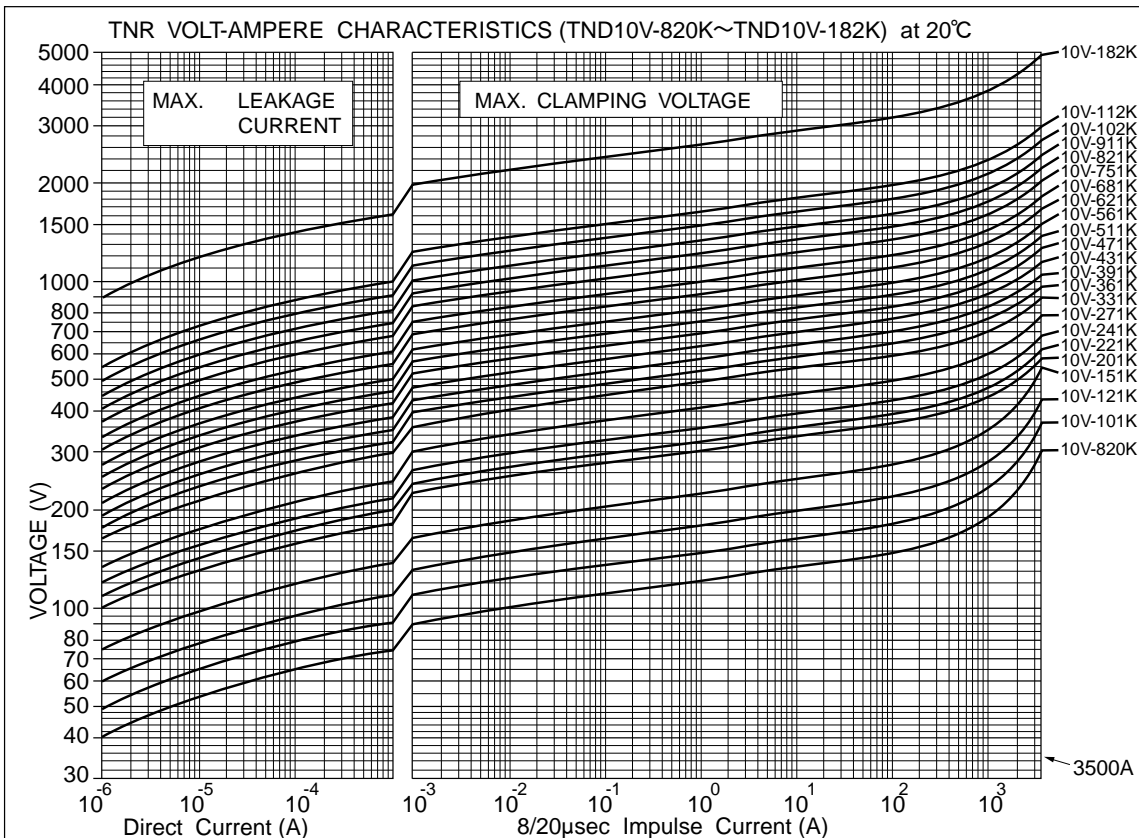
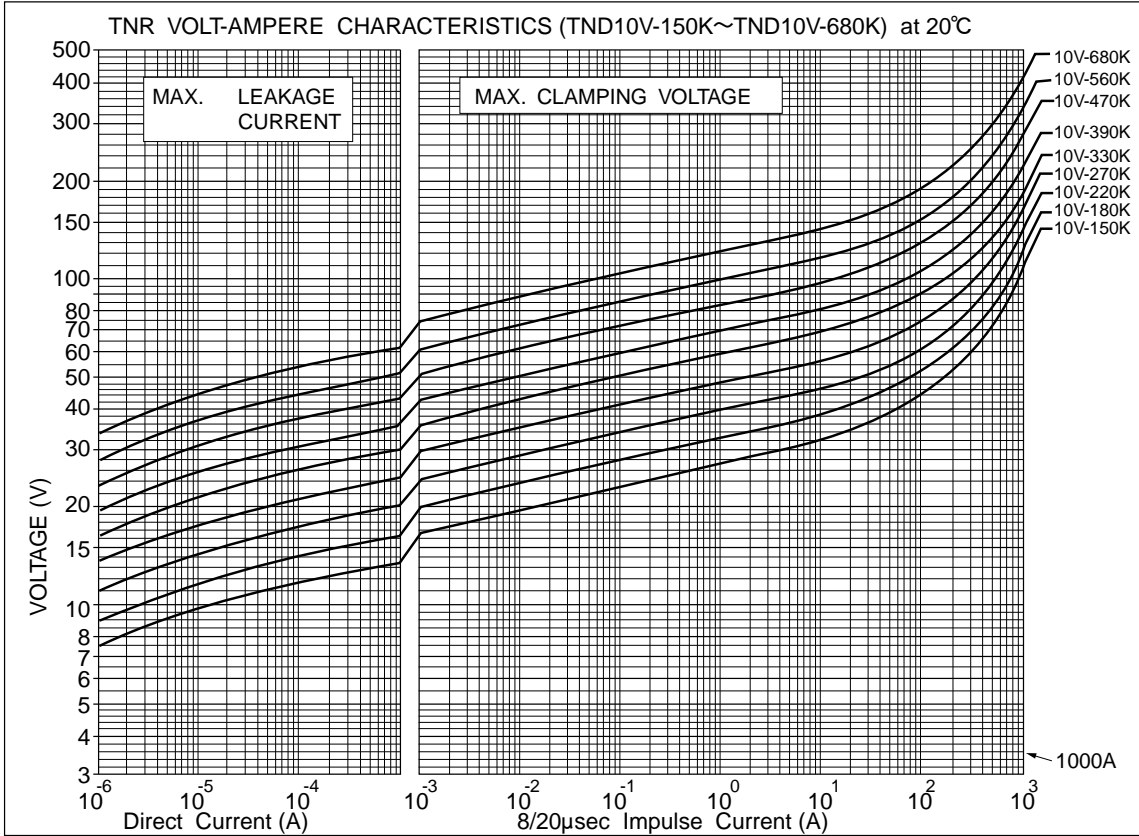



METAL OXIDE VARISTORS TNR™

V Series

◆ RATINGS (Type 12V)

Part Number	Previous Part Number (Just for your reference)	Maximum Ratings					Max. Clamping Voltage		Capacitance Typical @1kHz	Varistor Voltage V _{1mA}	T Max.	E ±1.0	W ₂ reference
		Max. Allowable Voltage		Max. Peak Current	Max. Energy	Rated Wattage	(A)	(V)					
		AC (Vrms)	DC (V)	8/20μs(A)	2ms(J)	(W)			(pF)	(V)	(mm)	(mm)	(mm)
TND12V-431KB00AAA0	TNR12V431K	275	350		55			710	375	430 (387 ~ 473)	6.0	2.0	7.8
TND12V-471KB00AAA0	TNR12V471K	300	385		60			775	345	470 (423 ~ 517)	6.2	2.1	7.8
TND12V-511KB00AAA0	TNR12V511K	320	410		67			845	330	510 (459 ~ 561)	6.4	2.3	7.8
TND12V-561KB00AAA0	TNR12V561K	350	460		67			922	305	560 (504 ~ 616)	6.7	2.5	7.9
TND12V-621KB00AAA0	TNR12V621K	385	505		67			1025	280	620 (558 ~ 682)	7.1	2.7	8.0
TND12V-681KB00AAA0	TNR12V681K	420	560	4,200A/1 time	67			1120	260	680 (612 ~ 748)	7.4	2.9	8.0
TND12V-751KB00AAA0	TNR12V751K	460	615		70	0.4	25	1240	235	750 (675 ~ 825)	7.8	3.1	8.1
TND12V-821KB00AAA0	TNR12V821K	510	670	3,000A/2 times	80			1355	220	820 (738 ~ 902)	8.1	3.4	8.2
TND12V-911KB00AAA0	TNR12V911K	550	745		90			1500	195	910 (819 ~ 1001)	8.6	3.7	8.4
TND12V-102KB00AAA0	TNR12V102K	625	825		100			1650	180	1000 (900 ~ 1100)	9.1	4.0	8.5
TND12V-112KB00AAA0	TNR12V112K	680	895		110			1815	165	1100 (990 ~ 1210)	9.7	4.4	8.7
TND12V-122KB00AAA0	TNR12V122K	720	980		120			1950	150	1200 (1080 ~ 1320)	10.5	4.7*	8.9**
TND12V-152KB00AAA0	TNR12V152K	860	1220		150			2440	135	1500 (1350 ~ 1650)	12.4	5.8*	9.5**
TND12V-182KB00AAA0	TNR12V182K	1000	1465		183			2970	110	1800 (1700 ~ 1980)	14.4	6.9*	10.2**

*E±2 **W₂±2

◆ DIMENSIONS [mm]

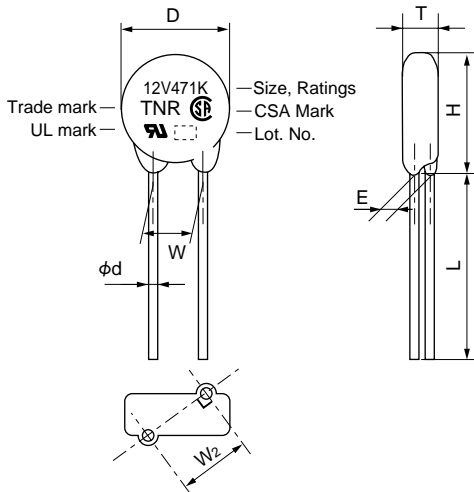

Part Number	D Max.	H Max.	T Max.	L Min.	φd ±0.05	W ±1.0
TND12V-431K to TND12V-102K	14.0	17.0	Ref. to RATINGS	20	0.8	7.5
TND12V-112K	15.0	18.0				
TND12V-122K	16.0	19.0				
TND12V-152K to TND12V-182K	16.0	19.0				



V Series

◆V-I CURVE (Type 12V)

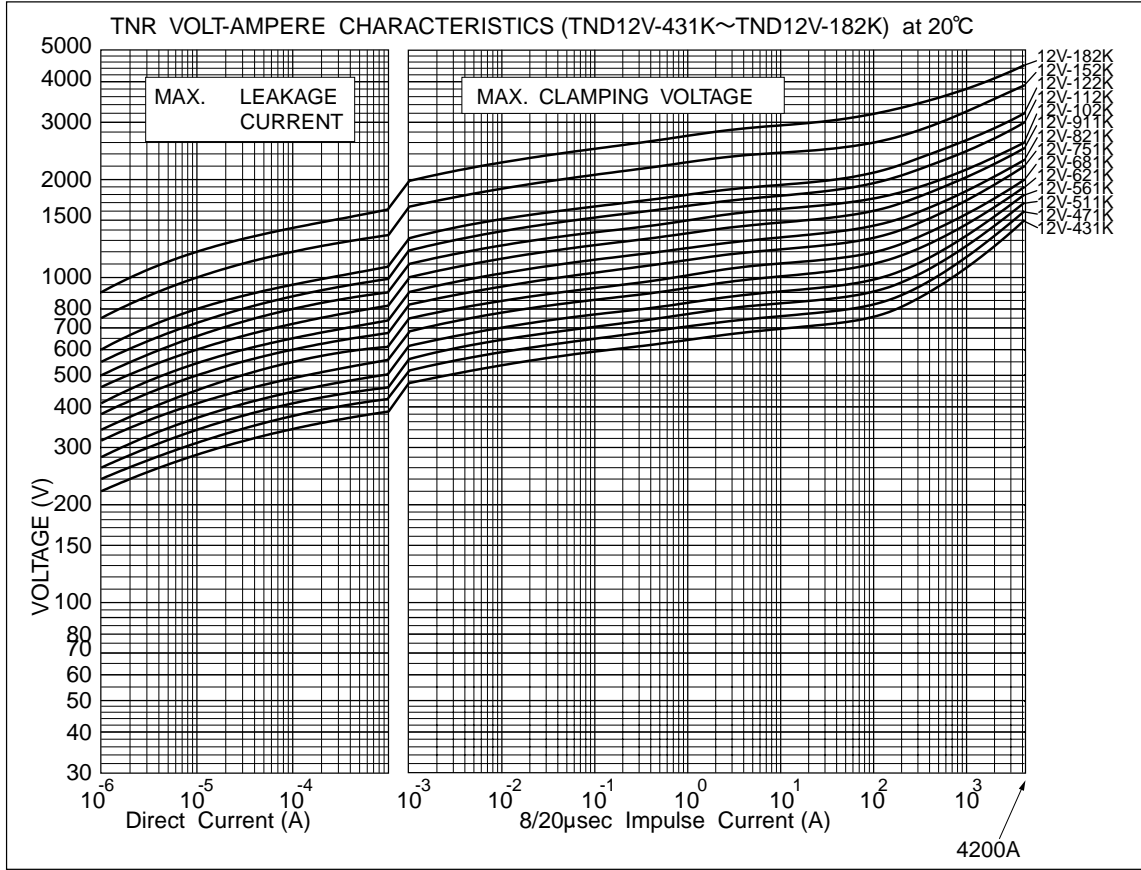

◆ RATINGS (Type 14V)

Part Number	Previous Part Number (Just for your reference)	Maximum Ratings					Max. Clamping Voltage	Capacitance Typical @1kHz	Varistor Voltage V _{1mA}	T Max.	E ±1.0	W2 Reference	
		Max. Allowable Voltage		Max. Peak Current	Max. Energy	Rated Wattage							
		AC (Vrms)	DC (V)	8/20μs(A)	2ms(J)	(W)							
TND14V-150KB00AAA0	TNR14V150K	8	12	2,000A/1 time	3.6	0.1	10	30	19,500	15 (13~ 17)	4.5	1.0	7.6
TND14V-180KB00AAA0	TNR14V180K	11	14		4.3			36	16,500	18 (16~ 20)	4.6	1.1	7.6
TND14V-220KB00AAA0	TNR14V220K	14	18		5.3			43	13,500	22 (20~ 24)	4.7	1.2	7.6
TND14V-270KB00AAA0	TNR14V270K	17	22	1,000A/2 times	6.5	0.6	50	53	12,000	27 (24~ 30)	4.8	1.4	7.6
TND14V-330KB00AAA0	TNR14V330K	20	26		7.9			65	10,000	33 (30~ 36)	5.0	1.6	7.7
TND14V-390KB00AAA0	TNR14V390K	25	30		9.4			77	9,000	39 (35~ 43)	4.9	1.3	7.6
TND14V-470KB00AAA0	TNR14V470K	30	37	6,000A/1 time	11	0.6	50	93	8,000	47 (42~ 52)	5.0	1.5	7.6
TND14V-560KB00AAA0	TNR14V560K	35	44		13			110	7,500	56 (50~ 62)	5.1	1.7	7.7
TND14V-680KB00AAA0	TNR14V680K	40	55		16			135	6,500	68 (61~ 75)	5.3	2.0	7.8
TND14V-820KB00AAA0	TNR14V820K	50	65	5,000A/2 times	20	0.6	50	135	3,000	82 (74~ 90)	4.5	1.1	7.6
TND14V-101KB00AAA0	TNR14V101K	60	85		25			165	2,700	100 (90~ 110)	4.7	1.3	7.6
TND14V-121KB00AAA0	TNR14V121K	75	100		30			200	2,500	120 (108~ 132)	4.9	1.4	7.6
TND14V-151KB00AAA0	TNR14V151K	95	125	5,000A/1 time	37	0.6	50	250	2,300	150 (135~ 165)	5.2	1.7	7.7
TND14V-181KB00AAA0	TNR14V181K	110	145		45			300	1,650	180 (162~ 198)	4.7	1.1	7.6
TND14V-201KB00AAA0	TNR14V201K	130	170		50			340	950	200 (185~ 225)	4.8	1.2	7.6
TND14V-221KB00AAA0	TNR14V221K	140	180	5,000A/2 times	55	0.6	50	360	850	220 (198~ 242)	4.9	1.3	7.6
TND14V-241KB00AAA0	TNR14V241K	150	200		60			395	800	240 (216~ 264)	5.0	1.4	7.6
TND14V-271KB00AAA0	TNR14V271K	175	225		70			455	700	270 (247~ 303)	5.2	1.5	7.6
TND14V-331KB00AAA0	TNR14V331K	210	270	4,500A/2 times	80	0.6	50	545	600	330 (297~ 363)	5.5	1.7	7.7
TND14V-361KB00AAA0	TNR14V361K	230	300		90			595	550	360 (324~ 396)	5.7	1.8	7.7
TND14V-391KB00AAA0	TNR14V391K	250	320		100			650	500	390 (351~ 429)	5.8	1.9	7.7
TND14V-431KB00AAA0	TNR14V431K	275	350	5,000A/1 time	110	0.6	50	710	460	430 (387~ 473)	6.0	2.1	7.8
TND14V-471KB00AAA0	TNR14V471K	300	385		125			775	420	470 (423~ 517)	6.2	2.2	7.8
TND14V-511KB00AAA0	TNR14V511K	320	410		136			845	390	510 (459~ 561)	6.4	2.4	7.9
TND14V-561KB00AAA0	TNR14V561K	350	460	4,500A/2 times	136	0.6	50	922	360	560 (504~ 616)	6.7	2.6	7.9
TND14V-621KB00AAA0	TNR14V621K	385	505		136			1,025	330	620 (558~ 682)	7.1	2.8	8.0
TND14V-681KB00AAA0	TNR14V681K	420	560		136			1,120	310	680 (612~ 748)	7.4	3.0	8.1
TND14V-751KB00AAA0	TNR14V751K	460	615	5,000A/1 time	150	0.6	50	1,240	280	750 (675~ 825)	7.8	3.3	8.2
TND14V-821KB00AAA0	TNR14V821K	510	670		165			1,355	250	820 (738~ 902)	8.1	3.5	8.3
TND14V-911KB00AAA0	TNR14V911K	550	745		180			1,500	230	910 (819~1,001)	8.6	3.9	8.5
TND14V-102KB00AAA0	TNR14V102K	625	825	4,500A/2 times	200	0.6	50	1,650	210	1,000 (900~1,100)	9.1	4.2	8.6
TND14V-112KB00AAA0	TNR14V112K	680	895		220			1,815	190	1,100 (990~1,210)	9.7	4.6	8.8
TND14V-122KB00AAA0	TNR14V122K	720	980		240			1,950	170	1,200 (1,080~1,320)	10.5	4.9*	9.0**
TND14V-152KB00AAA0	TNR14V152K	860	1,220	5,000A/1 time	300	0.6	50	2,440	150	1,500 (1,350~1,650)	12.4	6.0*	9.6**
TND14V-182KB00AAA0	TNR14V182K	1,000	1,465		360			2,970	120	1,800 (1,700~1,980)	14.4	7.1*	10.3**

*E±2 **W2±2

◆ DIMENSIONS [mm]

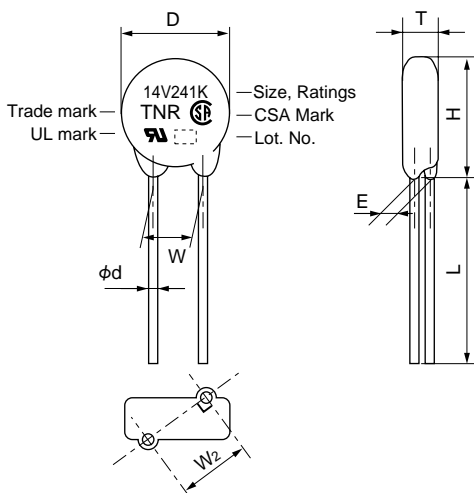

Part Number	D Max.	H Max.	T Max.	L Min.	φd ±0.05	W ±1.0
TND14V-150K to TND14V-511K	15.5	18.5	Ref. to RATINGS	20	0.8	7.5
TND14V-561K to TND14V-112K	16.0	19.0				
TND14V-122K to TND14V-182K	17.0	20.5				

V Series

◆V-I CURVE (Type 14V)

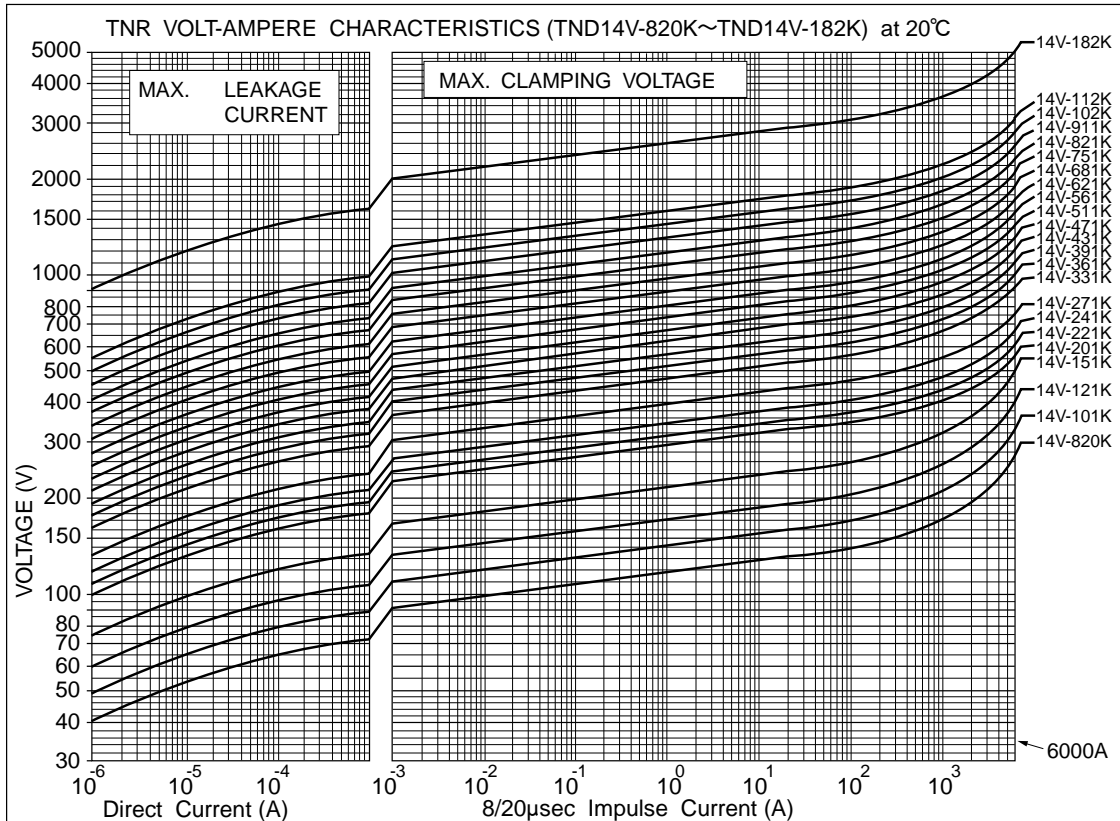
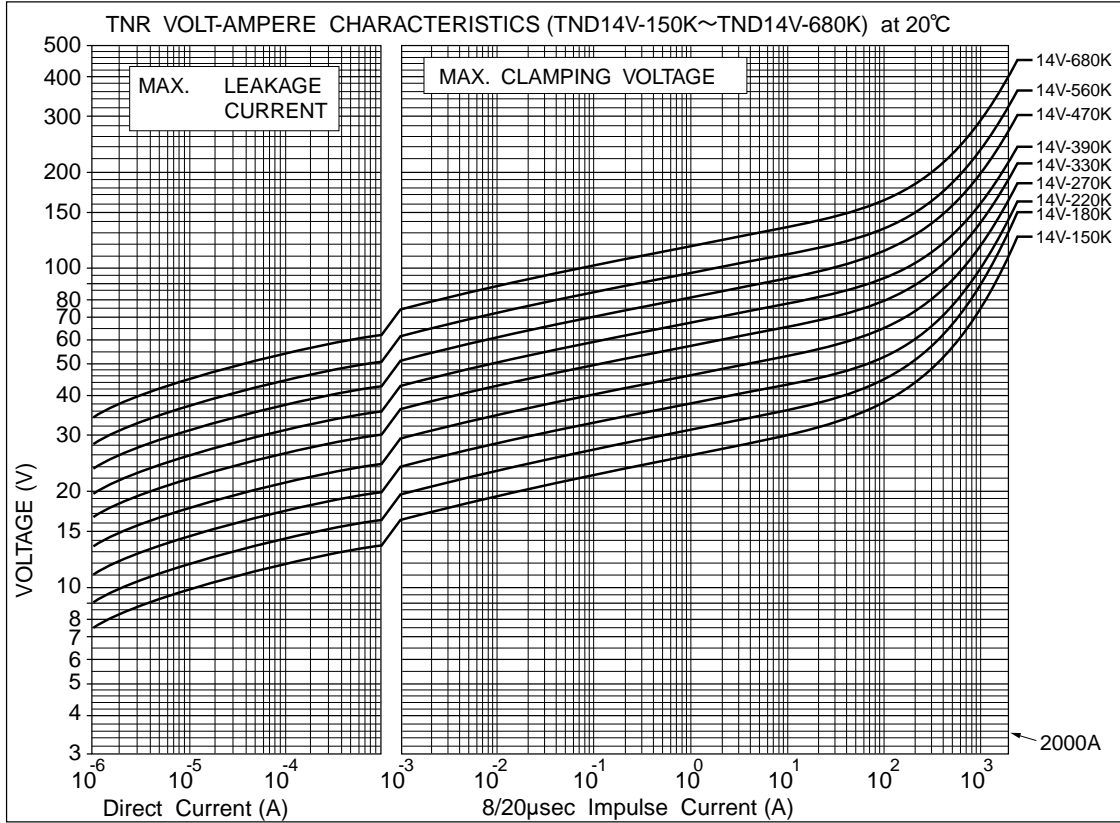



METAL OXIDE VARISTORS TNR™

V Series

◆ RATINGS (Type 20V)

Part Number	Previous Part Number (Just for your reference)	Maximum Ratings					Max. Clamping Voltage	Capacitance Typical @1kHz	Varistor Voltage V _{1mA}	T Max.	E ±1.0	W ₂ Reference	
		Max. Allowable Voltage		Max. Peak Current	Max. Energy	Rated Wattage							
		AC (V _{rms})	DC (V)	8/20μs(A)	2ms(J)	(W)							
TND20V-180KB00AAA0	TNR20V180K	11	14	3,000A/1 time	12	0.2	20	36	39,000	18 (16~ 20)	4.6	1.1	10.1
TND20V-220KB00AAA0	TNR20V220K	14	18		14			43	33,000	22 (20~ 24)	4.7	1.2	10.1
TND20V-270KB00AAA0	TNR20V270K	17	22		17			53	28,000	27 (24~ 30)	4.8	1.4	10.1
TND20V-330KB00AAA0	TNR20V330K	20	26	2,000A/2 times	21	1.0	100	65	24,000	33 (30~ 36)	5.0	1.6	10.1
TND20V-390KB00AAA0	TNR20V390K	25	30		25			77	21,000	39 (35~ 43)	4.9	1.3	10.1
TND20V-470KB00AAA0	TNR20V470K	30	37		30			93	19,000	47 (42~ 52)	5.0	1.5	10.1
TND20V-560KB00AAA0	TNR20V560K	35	44	10,000A/1 time	36	1.0	100	110	17,000	56 (50~ 62)	5.1	1.7	10.1
TND20V-680KB00AAA0	TNR20V680K	40	55		44			135	15,000	68 (61~ 75)	5.3	2.0	10.2
TND20V-820KB00AAA0	TNR20V820K	50	65		40			135	6,700	82 (74~ 90)	4.5	1.2	10.1
TND20V-101KB00AAA0	TNR20V101K	60	85	7,000A/2 times	50	1.0	100	165	6,100	100 (90~ 110)	4.7	1.4	10.1
TND20V-121KB00AAA0	TNR20V121K	75	100		60			200	5,600	120 (108~ 132)	4.9	1.5	10.1
TND20V-151KB00AAA0	TNR20V151K	95	125		75			250	5,100	150 (135~ 165)	5.2	1.8	10.2
TND20V-181KB00AAA0	TNR20V181K	110	145	10,000A/1 time	85	1.0	100	300	3,900	180 (162~ 198)	4.7	1.2	10.1
TND20V-201KB00AAA0	TNR20V201K	130	170		100			340	2,700	200 (185~ 225)	4.8	1.2	10.1
TND20V-221KB00AAA0	TNR20V221K	140	180		110			360	2,500	220 (198~ 242)	4.9	1.3	10.1
TND20V-241KB00AAA0	TNR20V241K	150	200	7,000A/2 times	120	1.0	100	395	2,300	240 (216~ 264)	5.0	1.4	10.1
TND20V-271KB00AAA0	TNR20V271K	175	225		135			455	2,000	270 (247~ 303)	5.2	1.5	10.1
TND20V-331KB00AAA0	TNR20V331K	210	270		160			545	1,700	330 (297~ 363)	5.5	1.7	10.1
TND20V-361KB00AAA0	TNR20V361K	230	300	6,500A/2 times	180	1.0	100	595	1,500	360 (324~ 396)	5.7	1.9	10.2
TND20V-391KB00AAA0	TNR20V391K	250	320		195			650	1,400	390 (351~ 429)	5.8	2.0	10.2
TND20V-431KB00AAA0	TNR20V431K	275	350		215			710	1,300	430 (387~ 473)	6.0	2.1	10.2
TND20V-471KB00AAA0	TNR20V471K	300	385	7,500A/1 time	250	1.0	100	775	1,200	470 (423~ 517)	6.2	2.3	10.3
TND20V-511KB00AAA0	TNR20V511K	320	410		273			845	1,100	510 (459~ 561)	6.4	2.4	10.3
TND20V-561KB00AAA0	TNR20V561K	350	460		273			922	1,000	560 (504~ 616)	6.7	2.6	10.3
TND20V-621KB00AAA0	TNR20V621K	385	505	7,500A/1 time	273	1.0	100	1,025	900	620 (558~ 682)	7.1	2.9	10.4
TND20V-681KB00AAA0	TNR20V681K	420	560		273			1,120	830	680 (612~ 748)	7.4	3.1	10.5
TND20V-751KB00AAA0	TNR20V751K	460	615		300			1,240	750	750 (675~ 825)	7.8	3.4	10.6
TND20V-821KB00AAA0	TNR20V821K	510	670	6,500A/2 times	325	1.0	100	1,355	700	820 (738~ 902)	8.1	3.6	10.6
TND20V-911KB00AAA0	TNR20V911K	550	745		360			1,500	620	910 (819~1,001)	8.6	4.0	10.8
TND20V-102KB00AAA0	TNR20V102K	625	825		400			1,650	560	1,000 (900~1,100)	9.1	4.3	10.9
TND20V-112KB00AAA0	TNR20V112K	680	895	6,500A/2 times	440	1.0	100	1,815	510	1,100 (990~1,210)	9.7	4.7	11.0
TND20V-122KB00AAA0	TNR20V122K	720	980		480			1,950	450	1,200 (1,080~1,320)	10.5	5.1*	11.2**
TND20V-152KB00AAA0	TNR20V152K	860	1,220		600			2,440	390	1,500 (1,350~1,650)	12.4	6.2*	11.8**
TND20V-182KB00AAA0	TNR20V182K	1,000	1,465	720	2,970	340	1,800 (1,700~1,980)	14.4	7.4*	12.4**			

*E±2 **W2±2

◆ DIMENSIONS [mm]

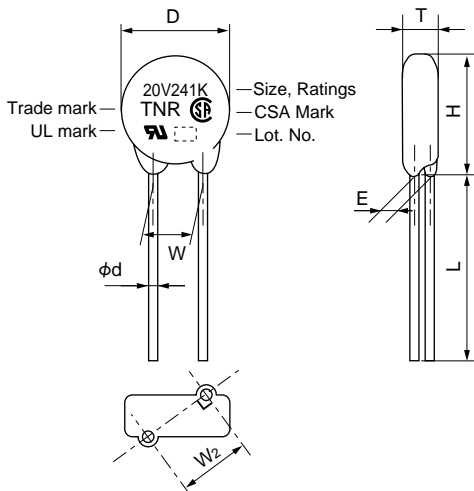

Part Number	D Max.	H Max.	T Max.	L Min.	φd ±0.05	W ±1.0
TND20V-180K to TND20V-511K	21.5	24.5	Ref. to Ratings	20	0.8	10.0
TND20V-561K to TND20V-112K	22.5	25.5				
TND20V-122K to TND20V-182K	23.5	28.0				



V Series

◆V-I CURVE (Type 20V)

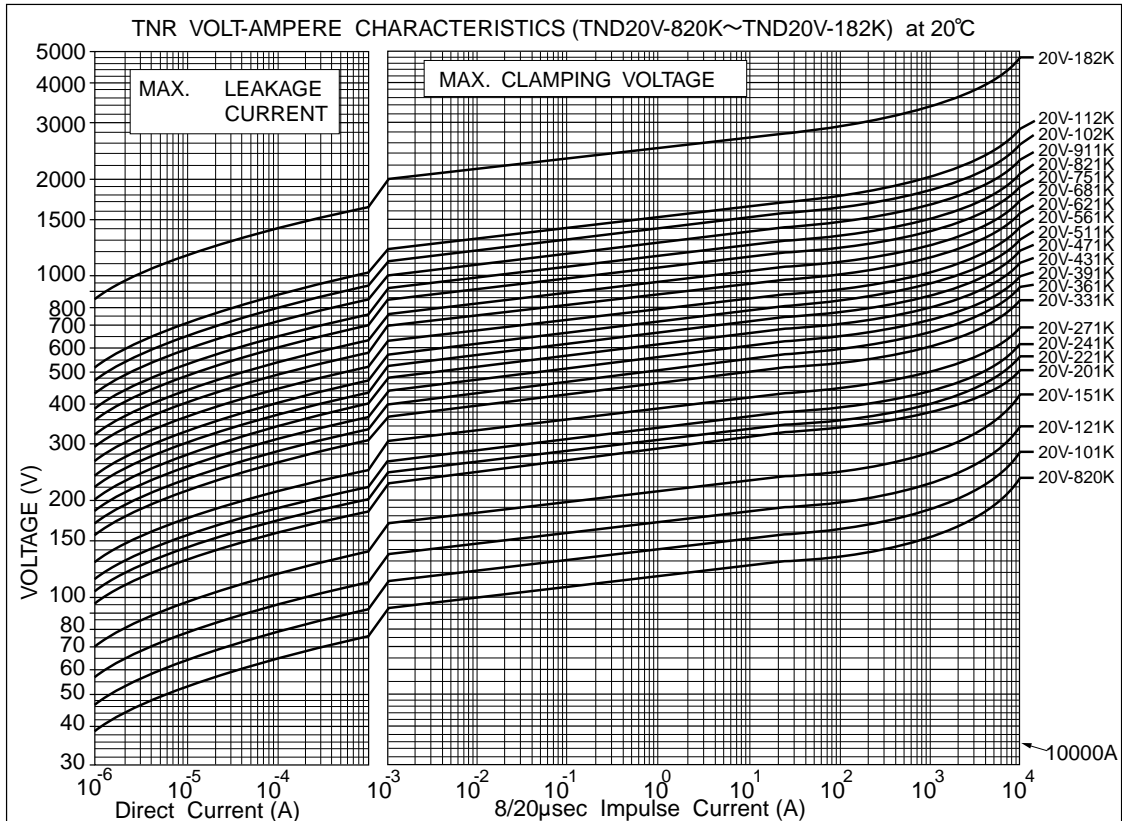
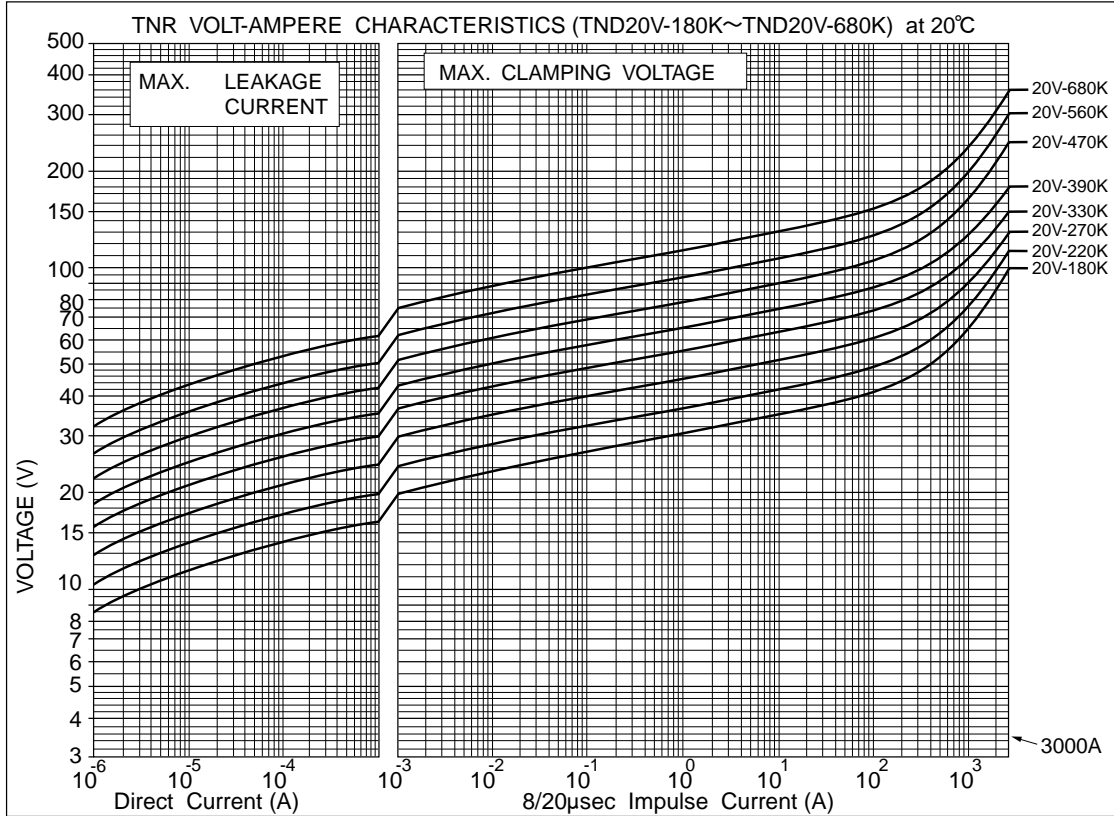



V Series

◆GENERAL SPECIFICATIONS

Item	Test Conditions	Specifications						
Standard Test Condition	20±5°C, 65±20%RH unless specified. However, if it does not affect test result, the condition can be 20±15°C, 65±20%RH also.							
Varistor Voltage	Voltage across varistor at specified current. <table border="1" style="margin-left: 20px;"> <thead> <tr> <th>Type</th> <th>Current CmA</th> </tr> </thead> <tbody> <tr> <td>5V</td> <td>0.1</td> </tr> <tr> <td>7V, 9V, 10V, 12V, 14V, 20V</td> <td>1.0</td> </tr> </tbody> </table>	Type	Current CmA	5V	0.1	7V, 9V, 10V, 12V, 14V, 20V	1.0	Satisfy the specification
Type	Current CmA							
5V	0.1							
7V, 9V, 10V, 12V, 14V, 20V	1.0							
Maximum Allowable Voltage	Maximum continuous AC voltage (50 to 60Hz AC) and maximum DC voltage which can be applied.	Satisfy the specification						
Maximum Peak Surge Current	Maximum surge current (8/20µs pulse wave to be applied once, or twice, 2 minutes apart) for varistor voltage change within ±10% of the initial value.	Satisfy the specification						
Energy Rating	Maximum energy (2 ms. square wave to be applied once) for varistor voltage change within ±10% of the initial value.	Satisfy the specification						
Rated Wattage	Maximum power (50 to 60Hz AC power to be applied for 1000 hours at 85±2°C) for varistor voltage change within ±10% of the initial value.	Satisfy the specification						
Maximum Clamping Voltage	Maximum voltage across varistor when 8/20µs rated current surge is applied.	Satisfy the specification						
Capacitance	Varistor's capacitance at 1kHz, standard test condition.	For reference only.						
Voltage Temperature Coefficient	$\frac{V_{cmA} \text{ at } 85^{\circ}\text{C} - V_{cmA} \text{ at } 25^{\circ}\text{C}}{V_{cmA} \text{ at } 25^{\circ}\text{C}} \times \frac{1}{60} \times 100 (\%/^{\circ}\text{C})$ VcmA : Actual varistor voltage	Within ±0.05%/°C						
Insulation	Short circuit the two leads of varistor, and put the varistor body into metal balls (1.6mm diameter) leaving 2mm epoxy coating outside. Then, apply 2.5kVrms between the leads and the metal balls for 60±5 sec..	The varistor shall withstand with no abnormality.						

◆ENVIRONMENTAL CHARACTERISTICS

Item	Test Conditions	Specifications
High Temperature Strage (Dry heat)	The specimen shall be subjected 125±2°C for 1000±12 hours without load.	$\Delta V_{cmA} \leq \pm 5\%$ However, on varistors have nominal varistor voltages from 15V to 68V, the varistor voltage change shall be $\Delta V_{cmA} \leq \pm 10\%$
Damp heat (Humidity)	The specimen shall be subjected to 40±2°C, 90 to 95%RH for 1000±12 hours without load.	$\Delta V_{cmA} \leq \pm 5\%$
Temperature Cycle	The temperature cycle shown below shall be repeated 5 cycles. -40±3°C, 30 minutes ⇔ +85±2°C, 30 minutes	$\Delta V_{cmA} \leq \pm 5\%$ No remarkable damage
High Temperature Operating	The specimen shall be subjected to 85±2°C with the maximum allowable voltage for 1000±12 hours.	$\Delta V_{cmA} \leq \pm 10\%$
Damp heat Operating	The specimen shall be subjected to 40±2°C, 90 to 95%RH with the maximum allowable voltage for 1000±12 hours.	$\Delta V_{cmA} \leq \pm 10\%$

Varistor voltage change of forward direction shall be measured in the test of unipolar surge life and DC load life.

Varistor voltage change is measured after stored at Standard Test Conditions for 1 to 2 hours.

Note : For 42V battery line, please contact our sales office.



◆MECHANICAL CHARACTERISTICS

Item	Test Conditions	Specifications												
Resistance to Soldering Heat	Each lead shall be dipped into a solder bath having a temperature of 350±10°C to a point 2.0 to 2.5 mm from the body of the unit, be held there for 3 ⁺¹ ₀ sec and then be stored at room temperature for 1 to 2 hours. The ΔVcmA and mechanical damage shall be examined. or Each lead shall be dipped into a solder bath having a temperature of 260±10°C to a point 2.0 to 2.5 mm from the body of the unit, be held there for 10±1 sec and then be stored at room temperature for 1 to 2 hours. The ΔVcmA and mechanical damage shall be examined.	ΔVcmA ≤±5% No remarkable damage												
Solderability	Each lead shall be dipped into a methanol solution (about 25%) of rosin for 5 to 10 sec. Then each lead shall be dipped into a solder. <table border="1"> <tr> <td>Solder</td> <td>Pb free (Sn-3.0Ag-0.5Cu)</td> <td>Eutectic (Sn/Pb)</td> </tr> <tr> <td>Solder Temp.</td> <td>245±5°C</td> <td>235±5°C</td> </tr> <tr> <td>Dipping Time</td> <td colspan="2">2±0.5sec.</td> </tr> <tr> <td>Dipping Depth</td> <td colspan="2">1.5 to 2.0mm (from the body)</td> </tr> </table>	Solder	Pb free (Sn-3.0Ag-0.5Cu)	Eutectic (Sn/Pb)	Solder Temp.	245±5°C	235±5°C	Dipping Time	2±0.5sec.		Dipping Depth	1.5 to 2.0mm (from the body)		At least, 95% of the leads shall be covered with solder uniformly.
Solder	Pb free (Sn-3.0Ag-0.5Cu)	Eutectic (Sn/Pb)												
Solder Temp.	245±5°C	235±5°C												
Dipping Time	2±0.5sec.													
Dipping Depth	1.5 to 2.0mm (from the body)													
Lead Pull Strength	Fix varistor body, and suspend specified weight toward direction of lead axis. <table border="1"> <tr> <td>Type</td> <td>Lead Diameter</td> <td>Weight</td> </tr> <tr> <td>5V, 7V, 9V</td> <td>0.6mm</td> <td>10N</td> </tr> <tr> <td>10V, 12V, 14V, 20V</td> <td>0.8mm</td> <td>10N</td> </tr> </table>	Type	Lead Diameter	Weight	5V, 7V, 9V	0.6mm	10N	10V, 12V, 14V, 20V	0.8mm	10N	No abnormality such as disconnection. ΔVcmA ≤±5%			
Type	Lead Diameter	Weight												
5V, 7V, 9V	0.6mm	10N												
10V, 12V, 14V, 20V	0.8mm	10N												
Lead Bend Strength	Fix varistor body vertically. Then suspend specified weight and bent the varistor body by 90°, and return it to the original position. Carry out the operation in the opposite direction and return the body to the original position. <table border="1"> <tr> <td>Type</td> <td>Lead Diameter</td> <td>Weight</td> </tr> <tr> <td>5V, 7V, 9V</td> <td>0.6mm</td> <td>5N</td> </tr> <tr> <td>10V, 12V, 14V, 20V</td> <td>0.8mm</td> <td>5N</td> </tr> </table>	Type	Lead Diameter	Weight	5V, 7V, 9V	0.6mm	5N	10V, 12V, 14V, 20V	0.8mm	5N	The leads shall not disconnect, slacken and peel off.			
Type	Lead Diameter	Weight												
5V, 7V, 9V	0.6mm	5N												
10V, 12V, 14V, 20V	0.8mm	5N												
Vibration	Mount varistor body on vibrator, and conduct the following vibration test. Peak-to-Peak amplitude : 1.5mm Vibration frequency range : 10Hz to 55Hz Sweeping time: Approximately one minute for 10Hz → 55Hz → 10Hz Direction and duration of vibration : Three directions of X, Y and Z. Two hours each. Six hours total.	No remarkable appearance abnormality. ΔVcmA ≤±5%												