

SAFETY STANDARDS for V Series

◆TNR V Series / Recognized safety standards

Standards	Category Name	Title	File No.	Varistor Voltage Range
UL1414	FOWX2	Across-the-line Capacitors, Antenna-coupling and Line-bypass Components	E65426	200 ~1800 V
UL1449 3rd. (1)	VZCA2 (USA)	Surge Protective Devices	E323623	82~1800 V
	VZCA8 (Canada)			
CSA C22.2 No.1 Class 2221 01	----	AUDIO AND VIDEO EQUIPMENT- Accessories and Parts for Electronic Equipment Varistor for Across-the-line use as transient protection on 120 V ac	LR-97864	200 ~1800 V
VDE	----	Varistor IEC 61051-1:2007-04 61051-2:1991 61051-2-2:1991	118623	15~1800 V

Recognized Part numbers

Rating	Varistor voltage (V)	Part Number											
		TND05V-***K	TND07V-***K	TND09V-***K	TND10V-***K	TND12V-***K	TND14V-***K	TND20V-***K					
820K	82	○	□	○	□	○	□	○	□	○	□	○	□
101K	100	○	□	○	□	○	□	○	□	○	□	○	□
121K	120	○	□	○	□	○	□	○	□	○	□	○	□
151K	150	○	□	○	□	○	□	○	□	○	□	○	□
181K	180	○	□	○	□	○	□	○	□	○	□	○	□
201K	200	○ ● ☆ □	○ ● ☆ □	○ ● ☆ □	○ ● ☆ □	○ ● ☆ □	○ ● ☆ □	○ ● ☆ □	○ ● ☆ □	○ ● ☆ □	○ ● ☆ □	○ ● ☆ □	○ ● ☆ □
221K	220	○ ● ☆ □	○ ● ☆ □	○ ● ☆ □	○ ● ☆ □	○ ● ☆ □	○ ● ☆ □	○ ● ☆ □	○ ● ☆ □	○ ● ☆ □	○ ● ☆ □	○ ● ☆ □	○ ● ☆ □
241K	240	○ ● ☆ □	○ ● ☆ □	○ ● ☆ □	○ ● ☆ □	○ ● ☆ □	○ ● ☆ □	○ ● ☆ □	○ ● ☆ □	○ ● ☆ □	○ ● ☆ □	○ ● ☆ □	○ ● ☆ □
271K	270	○ ● ☆ □	○ ● ☆ □	○ ● ☆ □	○ ● ☆ □	○ ● ☆ □	○ ● ☆ □	○ ● ☆ □	○ ● ☆ □	○ ● ☆ □	○ ● ☆ □	○ ● ☆ □	○ ● ☆ □
331K	330	○ ● ☆ □	○ ● ☆ □	○ ● ☆ □	○ ● ☆ □	○ ● ☆ □	○ ● ☆ □	○ ● ☆ □	○ ● ☆ □	○ ● ☆ □	○ ● ☆ □	○ ● ☆ □	○ ● ☆ □
361K	360	○ ● ☆ □	○ ● ☆ □	○ ● ☆ □	○ ● ☆ □	○ ● ☆ □	○ ● ☆ □	○ ● ☆ □	○ ● ☆ □	○ ● ☆ □	○ ● ☆ □	○ ● ☆ □	○ ● ☆ □
391K	390	○ ● ☆ □	○ ● ☆ □	○ ● ☆ □	○ ● ☆ □	○ ● ☆ □	○ ● ☆ □	○ ● ☆ □	○ ● ☆ □	○ ● ☆ □	○ ● ☆ □	○ ● ☆ □	○ ● ☆ □
431K	430	○ ● ☆ □	○ ● ☆ □	○ ● ☆ □	○ ● ☆ □	○ ● ☆ □	○ ● ☆ □	○ ● ☆ □	○ ● ☆ □	○ ● ☆ □	○ ● ☆ □	○ ● ☆ □	○ ● ☆ □
471K	470	○ ● ☆ □	○ ● ☆ □	○ ● ☆ □	○ ● ☆ □	○ ● ☆ □	○ ● ☆ □	○ ● ☆ □	○ ● ☆ □	○ ● ☆ □	○ ● ☆ □	○ ● ☆ □	○ ● ☆ □
511K	510		○ ● ☆ □	○ ● ☆ □	○ ● ☆ □	○ ● ☆ □	○ ● ☆ □	○ ● ☆ □	○ ● ☆ □	○ ● ☆ □	○ ● ☆ □	○ ● ☆ □	○ ● ☆ □
561K	560				○ ● ☆ □	○ ● ☆ □	○ ● ☆ □	○ ● ☆ □	○ ● ☆ □	○ ● ☆ □	○ ● ☆ □	○ ● ☆ □	○ ● ☆ □
621K	620				○ ● ☆ □	○ ● ☆ □	○ ● ☆ □	○ ● ☆ □	○ ● ☆ □	○ ● ☆ □	○ ● ☆ □	○ ● ☆ □	○ ● ☆ □
681K	680				○ ● ☆ □	○ ● ☆ □	○ ● ☆ □	○ ● ☆ □	○ ● ☆ □	○ ● ☆ □	○ ● ☆ □	○ ● ☆ □	○ ● ☆ □
751K	750				○ ● ☆ □	○ ● ☆ □	○ ● ☆ □	○ ● ☆ □	○ ● ☆ □	○ ● ☆ □	○ ● ☆ □	○ ● ☆ □	○ ● ☆ □
821K	820				○ ● ☆ □	○ ● ☆ □	○ ● ☆ □	○ ● ☆ □	○ ● ☆ □	○ ● ☆ □	○ ● ☆ □	○ ● ☆ □	○ ● ☆ □
911K	910				○ ● ☆ □	○ ● ☆ □	○ ● ☆ □	○ ● ☆ □	○ ● ☆ □	○ ● ☆ □	○ ● ☆ □	○ ● ☆ □	○ ● ☆ □
102K	1000				○ ● ☆ □	○ ● ☆ □	○ ● ☆ □	○ ● ☆ □	○ ● ☆ □	○ ● ☆ □	○ ● ☆ □	○ ● ☆ □	○ ● ☆ □
112K	1100				○ ● ☆ □	○ ● ☆ □	○ ● ☆ □	○ ● ☆ □	○ ● ☆ □	○ ● ☆ □	○ ● ☆ □	○ ● ☆ □	○ ● ☆ □
122K	1200				○ ● ☆ □	○ ● ☆ □	○ ● ☆ □	○ ● ☆ □	○ ● ☆ □	○ ● ☆ □	○ ● ☆ □	○ ● ☆ □	○ ● ☆ □
152K	1500				○ ● ☆ □	○ ● ☆ □	○ ● ☆ □	○ ● ☆ □	○ ● ☆ □	○ ● ☆ □	○ ● ☆ □	○ ● ☆ □	○ ● ☆ □
182K	1800				○ ● ☆ □	○ ● ☆ □	○ ● ☆ □	○ ● ☆ □	○ ● ☆ □	○ ● ☆ □	○ ● ☆ □	○ ● ☆ □	○ ● ☆ □

\*\*\*K": Rating

○ : UL1449, ● : UL1414, ☆ : CSA, □ : VDE, ■ : VDE and IEC 60950-1:2005,Annex Q

\*Coverage of UL1449

In UL1449, the coverage is prescribed according to surge current as follows.

Type	Equipment where TNR is used	Varistor Rating
Type 3	Cord Connected Direct Plug-In	TND10V(621K-182K), TND12V(431K-182K)
Type 2	Permanently Connected	TND14V(201K-182K), TND20V(820K-182K)
Others	Others	TND05V, TND07V, TND09V, TND10V(820K-561K), TND14V(820K-181K)

\*Recognized marking

UL, CSA : on the products      VDE : on the package label

**◆The AC Rated Voltage and Maximum Allowable Voltage**

Rating	Maximum Allowable Voltage		AC Rated Voltage (Vrms)		
	ACrms (V)	DC (V)	UL1414	UL1449	CSA
820K	50	65	N/A	45	N/A
101K	60	85	N/A	55	N/A
121K	75	100	N/A	68	N/A
151K	95	125	N/A	86	N/A
181K	110	145	N/A	100	N/A
201K	130	170	125	118	118
221K	140	180	125	127	127
241K	150	200	125	136	136
271K	175	225	125	159	159
331K	210	270	125	189	189
361K	230	300	125	209	209
391K	250	320	250	227	227
431K	275	350	250	250	250
471K	300	385	250	272	272
511K	315	410	250	286	286
561K	350	460	250	318	318
621K	385	505	250	350	350
681K	420	560	250	381	381
751K	460	615	250	418	418
821K	510	670	250	463	463
911K	550	745	250	500	500
102K	625	825	250	568	568
112K	680	895	250	600	600
122K	720	980	250	600	600
152K	860	1220	250	600	600
182K	1000	1465	250	600	600

**◆Application Notes**

1) CSA regulate "Maximum Rating Fuse" for using TNR to "Audio, Video and Similar Electronic Equipment" as below

Maximum Peak Current 8/20 $\mu$ s, 1 time(A)	Type of TNR	Maximum Rating of Fuse (A)
Up to 500		3
501~2000	TND05V, TND07V	5
2001~6000	TND09V, TND10V, TND12V, TND14V	10
Over 6000	TND20V	Not specified

2) "Rated Voltages" are specified for UL/CSA recognized components besides Maximum Allowable Voltage because of conforming to the Standby Current specified in safety standards.

In case of making an application to UL/CSA approval for equipment with TNR, the maximum AC operating voltage of equipment shall be lower than the TNR Rated Voltage.

**SAFETY STANDARDS for SE & SV Series**
**◆TNR SE & SV Series / Recognized safety standards**

Standards	Category Name	Title	File No.	Varistor Voltage Range	Symbol
UL1414	FOWX2	Across-the-line Capacitors, Antenna-coupling and Line-bypass Components	E65426	220~620 V	●
UL1449 3rd. (1)	VZCA2 (USA)	Surge Protective Devices	E323623	220~620 V	○
	VZCA8 (Canada)				
CSA C22.2 No.1 Class 2221 01	----	AUDIO AND VIDEO EQUIPMENT- Accessories and Parts for Electronic Equipment Varistor for Across-the-line use as transient protection on 120 V ac	LR-97864	220~620 V	☆
VDE	----	Varistor IEC 61051-1:2007-04 61051-2:1991 61051-2-2:1991	118623	220~620 V	□

**Recognized Part numbers**

Rating	Varistor voltage (V)	Part number			
		TND10SE***K TND10SV***K	TND12SE***K TND12SV***K	TND14SE***K TND14SV***K	TND20SE***K
221K	220	○ ● ☆ □		○ ● ☆ ■	○ ● ☆ □
241K	240	○ ● ☆ □		○ ● ☆ ■	○ ● ☆ □
271K	270	○ ● ☆ □		○ ● ☆ ■	○ ● ☆ □
431K	430	○ ● ☆ □	○ ☆ ■	○ ● ☆ ■	○ ● ☆ □
471K	470	○ ● ☆ □	○ ☆ ■	○ ● ☆ ■	○ ● ☆ □
511K	510	○ ● ☆ □	○ ☆ ■	○ ● ☆ ■	○ ● ☆ □
561K	560	○ ● ☆ □	○ ☆ ■	○ ● ☆ ■	○ ● ☆ □
621K	620	○ ● ☆ □	○ ☆ ■	○ ● ☆ ■	○ ● ☆ □

\*\*\*K": Rating

○ : UL1449, ● : UL1414, ☆ : CSA, □ : VDE, ■ : VDE and IEC 60950-1:2005,Annex Q

**\*Coverage of UL1449**

In UL1449, the coverage is prescribed according to surge current as follows.

Type	Equipment where TNR is used	Varistor Rating
Type 3	Cord Connected Direct Plug-In	TND10SE(621K), TND12SE(431K-621K) TND10SV(621K), TND12SV(431K-621K)
Type 2	Permanently Connected	TND14SE(221K-621K), TND20SE(221K-621K) TND14SV(221K-621K)
Others	Others	TND10SE(221K-511K) TND10SV(221K-511K)

**\*Recognized marking**

UL, CSA : on the products      VDE : on the package label

● This Specifies the lead forming specifications for Disk Type (V, SE, H series)

◆ FORM

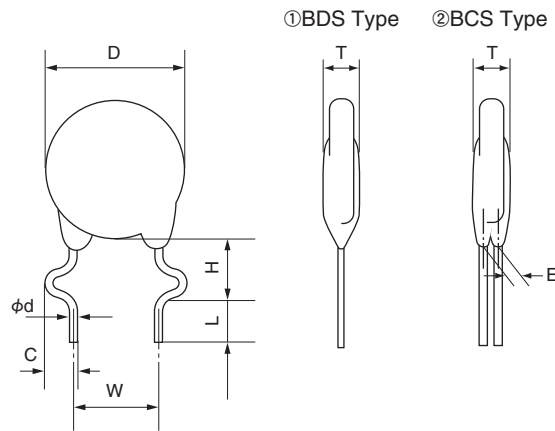

◆ DIMENSIONS

Unit : mm

Type	5V, 7V, 9V, 9H	10V, 12V, 14V, 12H, 15H	20V, 20SE, 23H
Lead style code	BDS	BCS	BCS
D	refer to each spec.	refer to each spec.	refer to each spec.
T	refer to each spec.	refer to each spec.	refer to each spec.
H	6.0 +2.0 -1.0	6.0 +2.0 -1.0	6.0 +2.0 -1.0
L	5.0±1.0	5.0±1.0	5.0±1.0
W	5.0±1.0	7.5±1.0	10.0±1.0
φd	0.6±0.05	0.8±0.05	0.8±0.05
C	2.0±0.5	2.0±0.5	2.0±0.5
E	—	refer to each spec.	refer to each spec.

◆ PART NUMBERING SYSTEM (BULK)

Code	Category	Code	Product Form	Varistor Voltage													
T	Metal Oxide Varistor TNR	ND	Disk Type	The first two digits are significant figures and the third one denote the number of following zeros.													

1

T

Category

2 3

ND

Product Form

4 5

12

Size

Code	Size
05	φ 5
07	φ 7
09	φ 9
10	φ 10
12	φ 12
14	φ 14
15	φ 15
20	φ 20
23	φ 23

6 7

V-

Series

Code	Series
V-	V Series
SE	SE Series
H-	H Series
GF	GF Series

8 9 10

471

Varistor Voltage

11

K

Varistor Voltage Tolerance

Code	Varistor Volt. Tolerance
K	±10%

12 13 14

B00

Bulk Forming Code

15 16 17 18

AAA0

Design code

Form-A      Form-B (Parallel)

Note : The Code (300) is the Previous Code.

- This Specifies taping specifications for TNR varistors which have normal disk diameter of 5 to 15mm and nominal varistor voltage of 15 to 510V.
- These taping specifications conform to JIS C 0805.

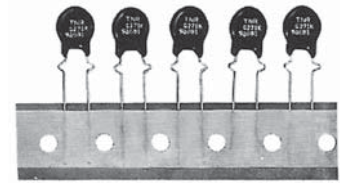

◆ PART NUMBERING SYSTEM

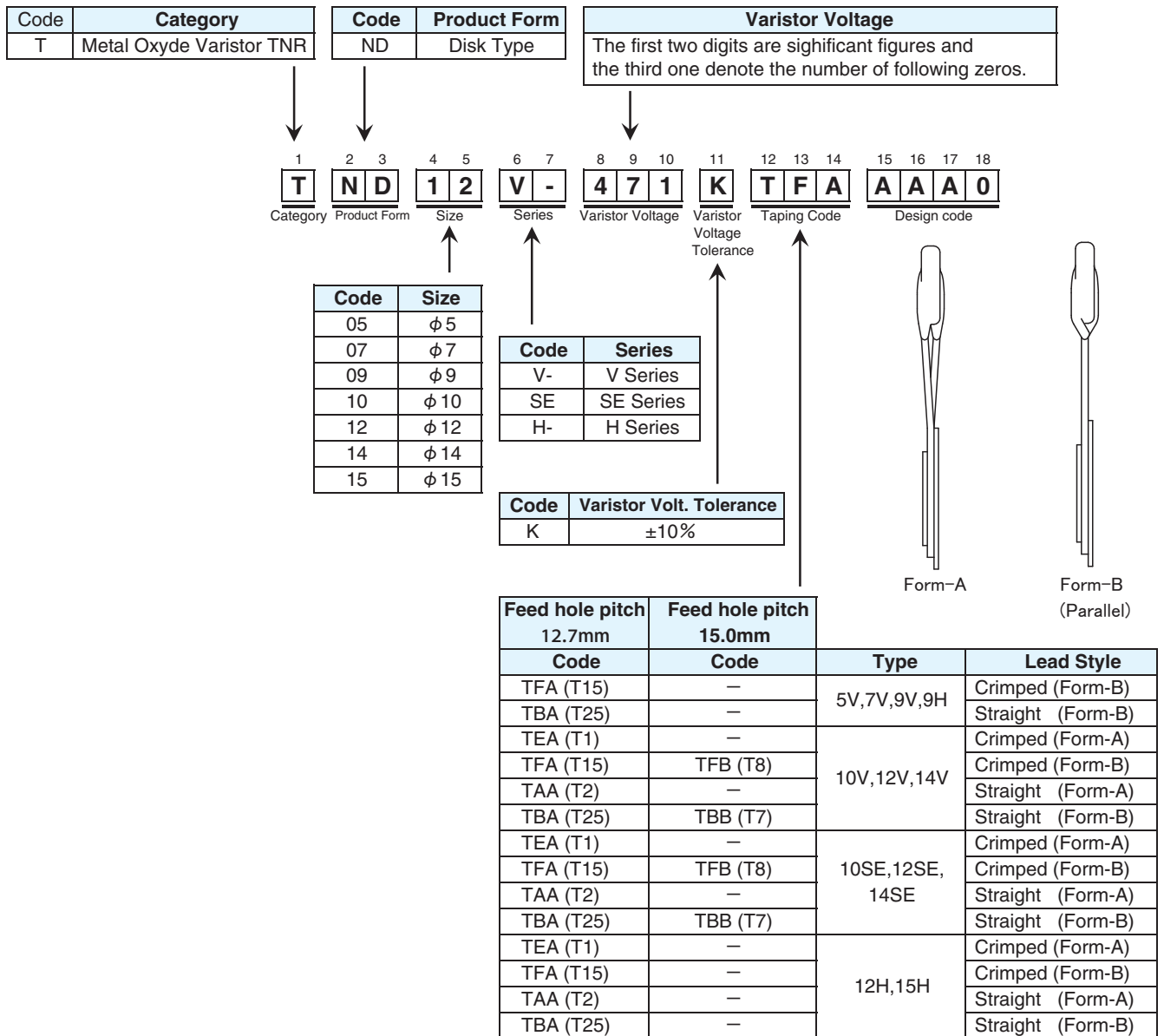

Note : The Code (T1,T15,T2,T25,T8,T7) are the old taping code.

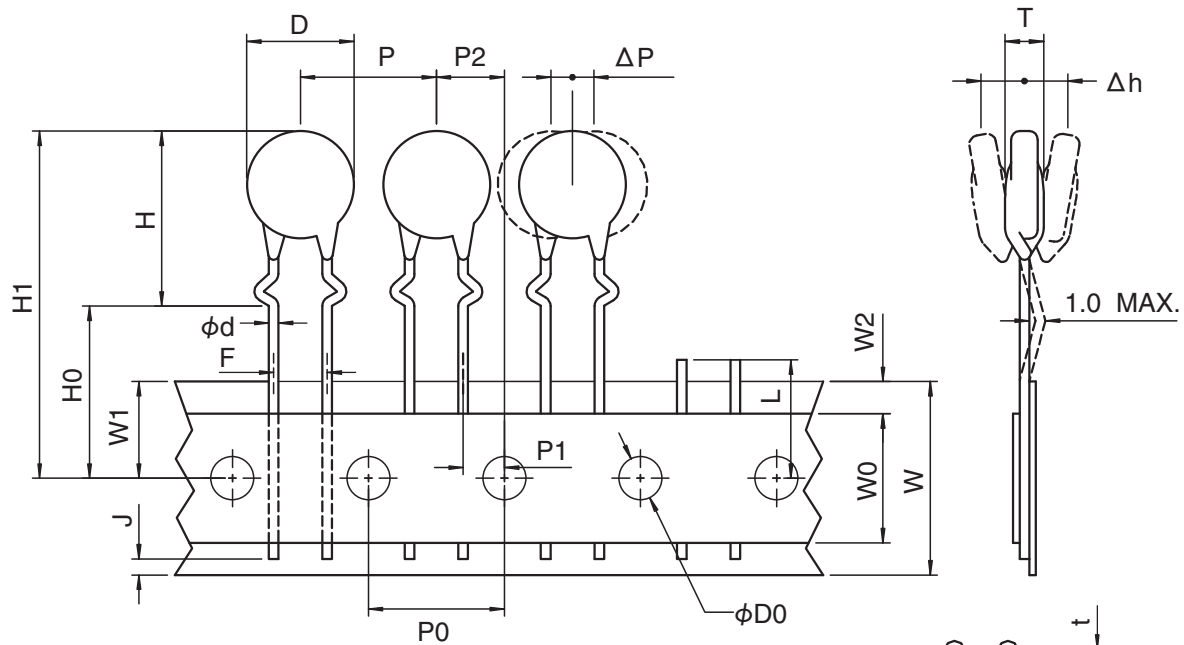
**◆5V, 7V, 9V, 9H : TYPE TFA(T15) (Crimped Lead)**

Type	5V	7V	9V	9H
Height (H Max.)	13.0	14.5	17.5	16.0
Component Height (H1 Max.)	30.0	31.0	34.0	33.0

**◆TYPE TFA(T15)**

Parameter	Code	Dimensions (mm)	Note
Diameter of component	D	—	Refer to the applicable detail spec
Thickness of component	T	—	Refer to the applicable detail spec
Lead diameter	φd	0.6±0.05	
Pitch of component	P	12.7±1.0	
Feed hole pitch	P0	12.7±0.3	Cumulative pitch error : ±1 mm/20 pitches
Feed hole diameter	φD0	4.0±0.2	
Feed hole center to lead	P1	3.85±0.7	Measured at the upper end of tape
Feed hole center to component center	P2	6.35±1.3	
Feed hole position	W1	9.0±0.5	
Lead spacing	F	5.0±0.8	
Deviation across tape	Δh	0±2.0	
Deviation along tape	ΔP	0±1.0	
Carrier tape width	W	18.0± <sup>0.0</sup> <sub>0.5</sub>	
Hold down tape width	W0	5.0 Min.	
Total tape thickness	t	0.6±0.3	
Hold down tape position	W2	3.0 Max.	
Seating plane height	H0	16.0±0.5	
Component height	H1	—	Please refer to the above list
Lead position	J	6.0 Max.	
Defective article cut position	L	11.0 Max.	

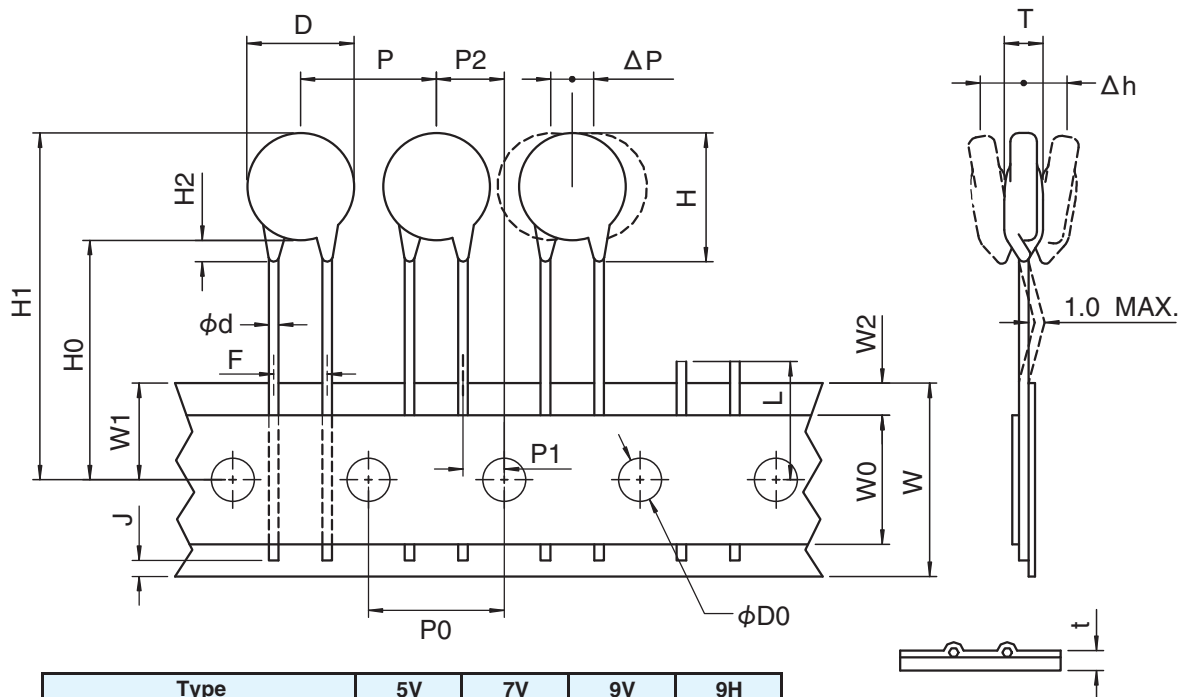
**◆ 5V, 7V, 9V, 9H : TYPE TBA(T25) (Straight Lead)**

Type	5V	7V	9V	9H
Height (H Max.)	10.0	11.5	14.5	14.0
Component Height (H1 Max.)	29.0	30.0	33.0	32.0

**◆TYPE TBA(T25)**

Parameter	Code	Dimensions (mm)	Note
Diameter of component	D	—	Refer to the applicable detail spec
Thickness of component	T	—	Refer to the applicable detail spec
Lead diameter	φd	0.6±0.05	
Pitch of component	P	12.7±1.0	
Feed hole pitch	P0	12.7±0.3	Cumulative pitch error : ±1 mm/20 pitches
Feed hole diameter	φD0	4.0±0.2	
Feed hole center to lead	P1	3.85±0.7	Measured at the upper end of tape
Feed hole center to component center	P2	6.35±1.3	
Feed hole position	W1	9.0±0.5	
Lead spacing	F	5.0±0.8	
Deviation across tape	Δh	0±2.0	9V : 34.0 Max.
Deviation along tape	ΔP	0±1.0	
Carrier tape width	W	18.0± <sup>0.8</sup> <sub>0.8</sub>	
Hold down tape width	W0	5.0 Min.	
Total tape thickness	t	0.6±0.3	
Hold down tape position	W2	3.0 Max.	
Height from tape center to component base	H0	20.0± <sup>1.0</sup> <sub>1.0</sub>	
Component height	H1	—	Please refer to the above list
	H2	3.0 Max.	
Lead position	J	6.0 Max.	
Defective article cut position	L	11.0 Max.	

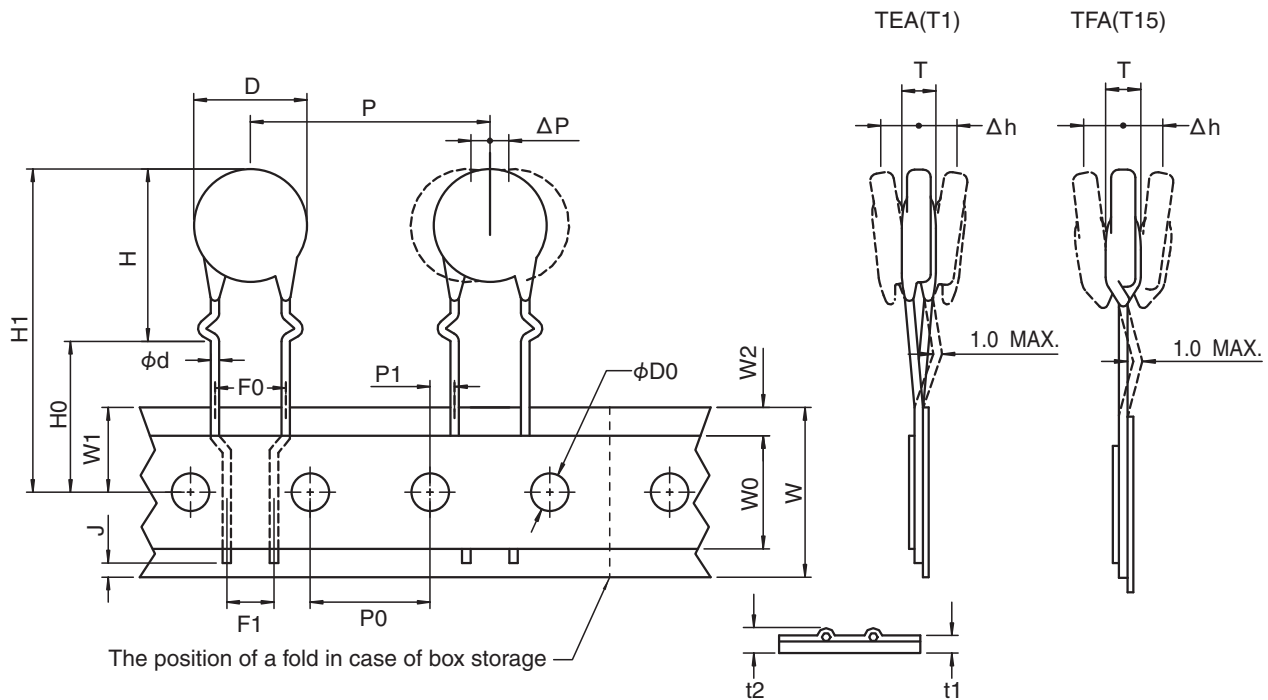
**◆10V, 12V, 14V, 10SE, 12SE, 14SE, 12H, 15H : TYPE TEA(T1), TFA(T15) (Crimped Lead)**

Type	10V	12V	14V	10SE	12SE	14SE	12H	15H
Height (H Max.)	17.5	19.0	21.0	21.0	24.0	25.0	21.0	24.0
Component Height (H1 Max.)	35.0	36.0	38.0	38.0	41.0	42.0	38.0	41.0

**◆TYPE TEA(T1), TFA(T15)**

Parameter	Code	Dimensions (mm)	Note
Diameter of component	D	—	Refer to the applicable detail spec
Thickness of component	T	—	Refer to the applicable detail spec
Lead diameter	$\phi d$	0.8±0.05	
Pitch of component	P	25.4±1.0	
Feed hole pitch	P0	12.7±0.3	Cumulative pitch error : ±1 mm/20 pitches
Feed hole diameter	$\phi D0$	4.0±0.2	
Feed hole center to lead	P1	2.6±0.5	Measured at the upper end of tape
Feed hole position	W1	9.0±0.5	
Lead spacing	F0	7.5±0.8	
	F1	5.0 Nom.	
Deviation across tape	$\Delta h$	0±2.0	
Deviation along tape	$\Delta P$	0±1.0	
Carrier tape width	W	18.0 <sup>+1.0</sup> <sub>-0.5</sub>	
Hold down tape width	W0	5.0 Min.	
Total tape thickness	t	0.6±0.3	
Hold down tape position	W2	3.0 Max.	
Seating plane height	H0	16.0±1.0	
Component height	H1	—	Please refer to the above list
Lead position	J	6.0 Max.	

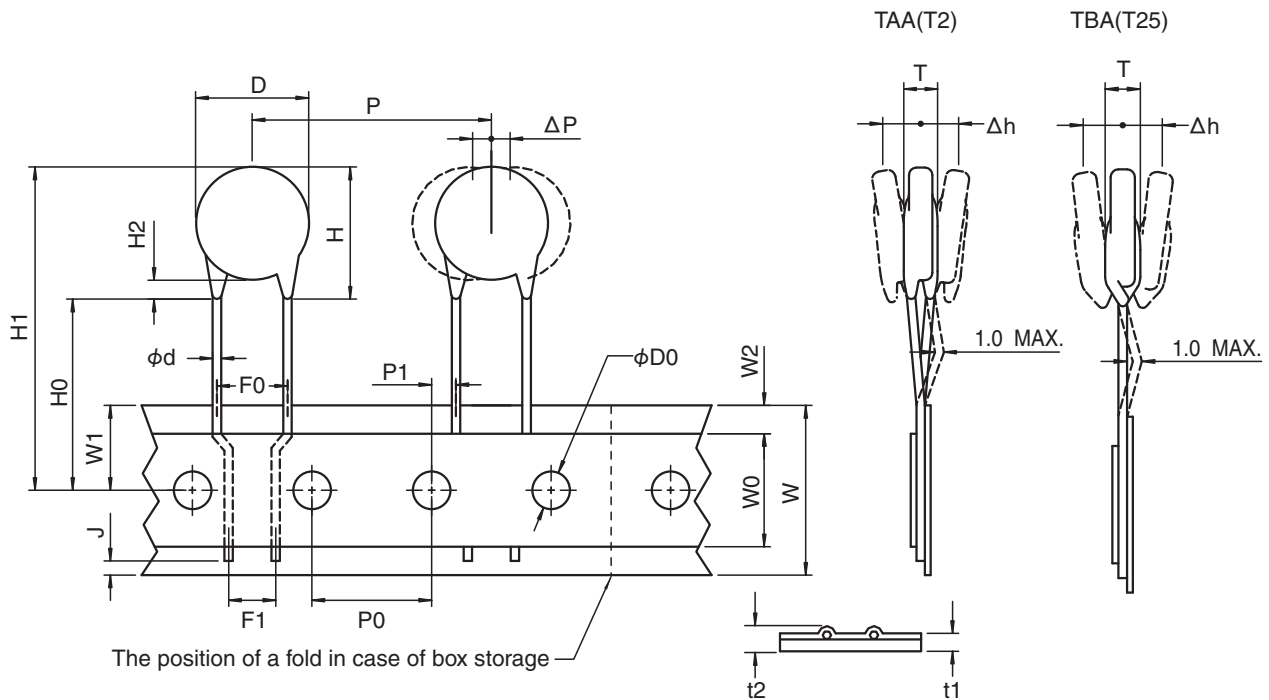
**◆10V, 12V, 14V, 10SE, 12SE, 14SE, 12H, 15H : TYPE TAA(T2), TBA(T25) (Straight Lead)**

Type	10V	12V	14V	10SE	12SE	14SE	12H	15H
Height (H Max.)	15.5	17.0	19.0	18.5	23.0	24.0	17.0	20.0
Component Height (H1 Max.)	40.0	41.0	43.0	43.0	48.0	49.0	41.0	44.0

**◆TYPE TAA(T2), TBA(T25)**

Parameter	Code	Dimensions (mm)	Note
Diameter of component	D	—	Refer to the applicable detail spec
Thickness of component	T	—	Refer to the applicable detail spec
Lead diameter	φd	0.8±0.05	
Pitch of component	P	25.4±1.0	
Feed hole pitch	P0	12.7±0.3	Cumulative pitch error : ±1 mm/20 pitches
Feed hole diameter	φD0	4.0±0.2	
Feed hole center to lead	P1	2.6±0.5	Measured at the upper end of tape
Feed hole position	W1	9.0±0.5	
Lead spacing	F0	7.5±0.8	
	F1	5.0 Nom.	
Deviation across tape	Δh	0±2.0	
Deviation along tape	ΔP	0±1.0	
Carrier tape width	W	18.0±0.5	
Hold down tape width	W0	5.0 Min.	
Total tape thickness	t	0.6±0.3	
Hold down tape position	W2	3.0 Max.	
Height from tape center to component base	H0	20.0 Min.	SE : 19.0 Min.
Component height	H1	—	Please refer to the above list
	H2	3.0 Max.	
Lead position	J	6.0 Max.	

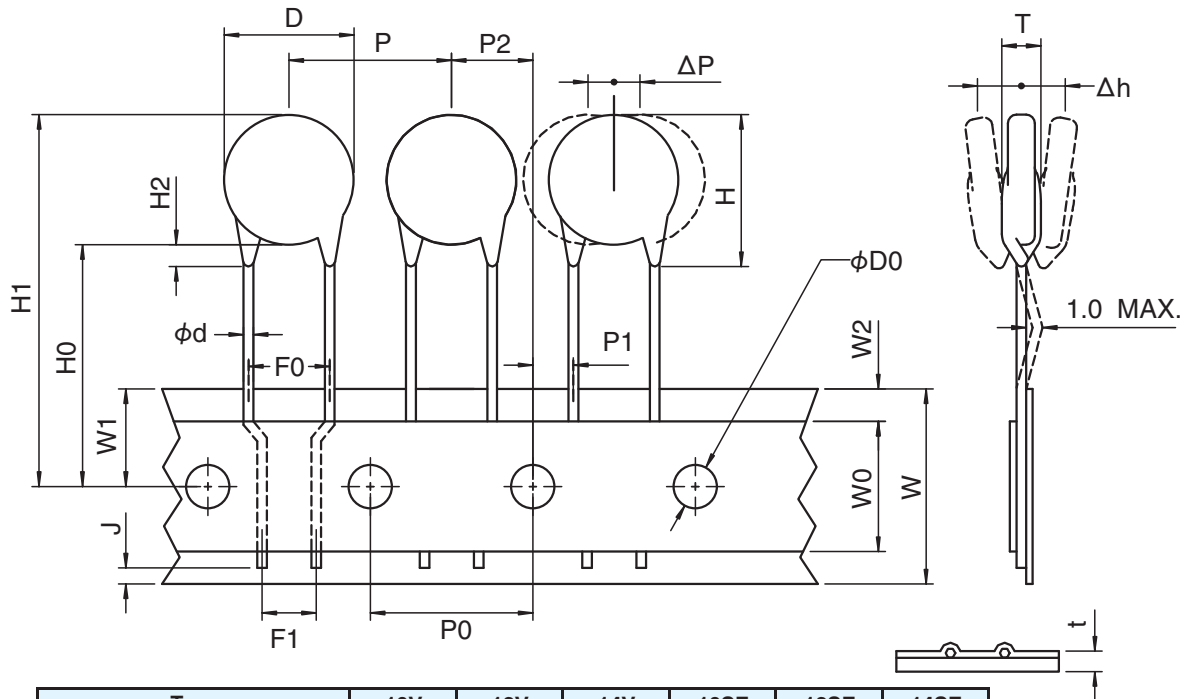
**◆10V, 12V, 14V, 10SE, 12SE, 14SE : TYPE TBB(T7) (Straight Lead, 15mm Pitch)**

Type	10V	12V	14V	10SE	12SE	14SE
Height (H Max.)	15.5	17.0	19.0	18.5	23.0	24.0
Component Height (H1 Max.)	37.0	39.0	41.0	40.0	45.0	46.0

**◆TYPE TBB(T7)**

Parameter	Code	Dimensions (mm)	Note
Diameter of component	D	—	Refer to the applicable detail spec (14V : 15.0 Max.)
Thickness of component	T	—	Refer to the applicable detail spec
Lead diameter	φd	0.8±0.05	
Pitch of component	P	15.0±1.0	14SE : 30.0 ±1.0 mm
Feed hole pitch	P0	15.0±0.3	Cumulative pitch error : ±1 mm/20 pitches
Feed hole diameter	φD0	4.0±0.2	
Feed hole center to lead	P1	3.75±0.5	Measured at the upper end of tape
Feed hole center to component center	P2	7.5±1.3	
Feed hole position	W1	9.0±0.5	
Lead spacing	F0	7.5±0.8	
	F1	5.0 Nom.	
Deviation across tape	Δh	0±2.0	
Deviation along tape	ΔP	0±1.3	
Carrier tape width	W	18.0± <sup>1.0</sup> <sub>0.8</sub>	
Hold down tape width	W0	5.0 Min.	
Total tape thickness	t	0.6±0.3	
Hold down tape position	W2	3.0 Max.	
Height from tape center to component base	H0	20.0± <sup>1.5</sup> <sub>1.0</sub>	
Component height	H1	—	Please refer to above list
	H2	3.0 Max.	
Lead position	J	6.0 Max.	

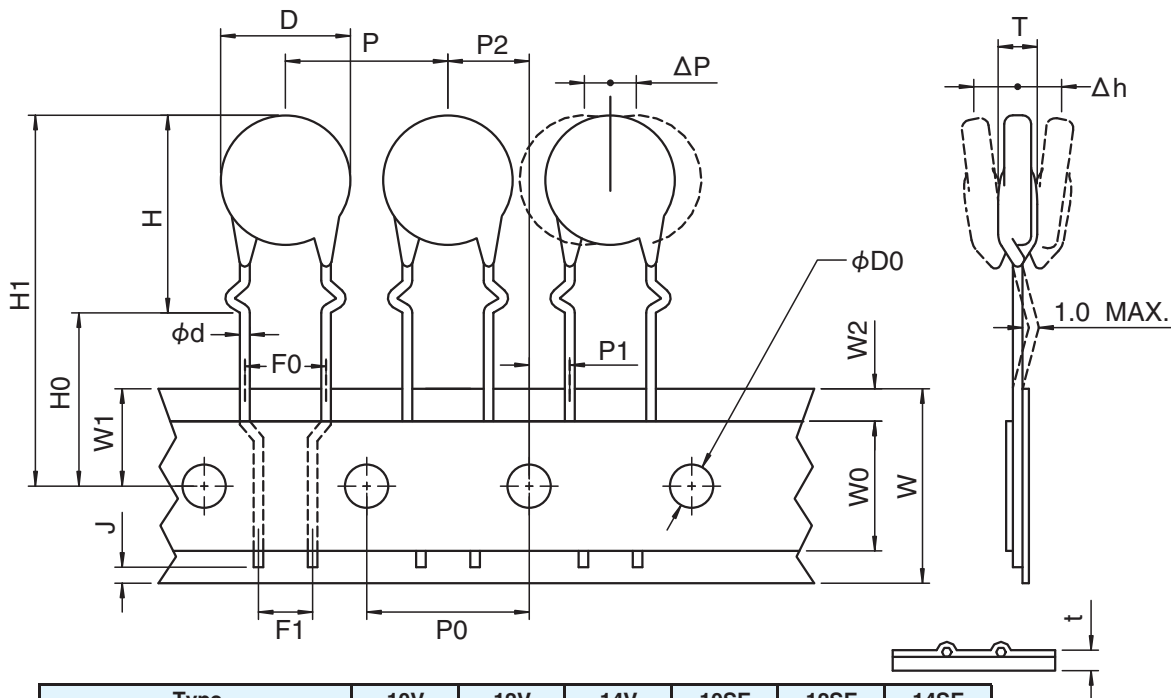
**◆10V, 12V, 14V, 10SE, 12SE, 14SE : TYPE TFB(T8) (Crimped Lead, 15mm Pitch)**

Type	10V	12V	14V	10SE	12SE	14SE
Height (H Max.)	17.5	19.0	21.0	21.0	24.0	25.0
Component Height (H1 Max.)	35.0	36.0	38.0	38.0	41.0	42.0

**◆TYPE TFB(T8)**

Parameter	Code	Dimensions (mm)	Note
Diameter of component	D	—	Refer to the applicable detail spec (14V : 15.0 Max.)
Thickness of component	T	—	Refer to the applicable detail spec
Lead diameter	φd	0.8±0.05	
Pitch of component	P	15.0±1.0	14SE : 30.0±1.0 mm
Feed hole pitch	P0	15.0±0.3	Cumulative pitch error : ±1 mm/20 pitches
Feed hole diameter	φD0	4.0±0.2	
Feed hole center to lead	P1	3.75±0.5	Measured at the upper end of tape
Feed hole center to component center	P2	7.5±1.3	
Feed hole position	W1	9.0±0.5	
Lead spacing	F0	7.5±0.8	
	F1	5.0 Nom.	
Deviation across tape	Δh	0±2.0	
Deviation along tape	ΔP	0±1.3	
Carrier tape width	W	18.0±0.5	
Hold down tape width	W0	5.0 Min.	
Total tape thickness	t	0.6±0.3	
Hold down tape position	W2	3.0 Max.	
Seating plane height	H	—	10V ; 17.5 Max. 14V ; 21.0 Max.
	H0	16.0±1.0	
Component height	H1	—	Please refer to above list
Lead position	J	6.0 Max.	