



METAL OXIDE VARISTORS TNR™

CAT. No. E1006T

INDEX		
PRODUCT SEARCH	SERIES TABLE	➔
PRODUCTION GUIDE	PRECAUTIONS AND GUIDELINES	➔
	GROUP CHART	➔
	PART NUMBERING SYSTEM	➔
	TECHNICAL TERMS ON VARISTORS	➔
	SAFETY STANDARDS	➔
	TAPING SPECIFICATION	➔
	PACKAGING	➔
	MINIMUM ORDER QUANTITY	➔
	PRODUCT SPECIFICATIONS	V Series
SE Series		➔
SV Series		➔
H Series		➔
GF Series		➔
32HP Series		➔
A Series		➔
E Series		➔
PULSE LIFE TIME RATINGS		➔
APPLICATION EXAMPLES		➔



Item	Series	Features
Disk Type	V Series	Very Large Surge Capability
	SE Series	Non Flammable Type Very Large Surge Capability
	SV Series	Non Flammable and Little Scatter Type Very Large Surge Capability
	H Series	High Energy Low Voltage
	GF Series	Disk Type with Thermal Fuse
	32HP Series	High Energy with Heat Sink
Axial Lead Type	A Series	Axial Lead Type High Voltage
Case Type	E Series	Case Type High Energy

- 1** The performance of varistors may deteriorate, the inside elements may be damaged, and they cause the varistors to smoke or catch fire, if the following precautions are not observed.
- (1) Do not use varistors in places whose temperature exceeds their rated operating temperature due to direct sunlight or heating objects.
 - (2) Do not use varistors in a humid place directly exposed to the weather or steam.
 - (3) Do not use varistors in places filled with dust, salt-mist or corrosive gas.
 - (4) Apply soldering conditions within the limits prescribed in the catalog or product specifications.
 - (5) Do not use solvents such as thinner and acetone which dissolve or make the exterior covering of varistors deteriorate.
Ultrasonic cleaning shall be so set that the vibration can not travel the assembly boards.
 - (6) Do not expose varistors to intense vibration, shock (drop shock etc.) or pressure making the exterior covering or inside element crack.
 - (7) Do not apply high voltage exceeding the rated maximum applying voltage to varistors.
In the case of automotive jump starts, however, use the varistors within short-term allowable voltage limits prescribed in the catalog.
If voltage wave form is not complete DC, a maximum value of peak voltages shall not exceed the rated maximum applying voltage.
 - (8) Do not apply peak currents exceeding the rated maximum energy.
 - (9) When peak currents are repeatedly applied to varistors, do not exceed the pulse life time ratings prescribed in the catalog.
 - (10) When peak currents are intermittently applied to varistors at short intervals, do not exceed the rated wattage.
 - (11) Using varistors in circuits whose frequency exceeds 1kHz may damage their elements by heat generation due to dielectric loss.
 - (12) In the case of coating or molding varistors with resin, do not use the resin which makes the varistors deteriorate.
 - (13) Do not install varistors in places near by flammable substances.
- 2** Varistors may blow up, if the following precautions are not observed.
- (1) Do not use varistors in circuits applied peak currents exceeding the specified limits.
 - (2) Do not exceed the rated maximum applying voltage.
- 3** Varistors do not function but damages devices, if the following precautions are not observed.
- (1) Hold the root of the varistor lead when bending or cutting the lead.
 - (2) The lead close to insulation cover shall not be bent or applied to outer force.
 - (3) When soldering the lead, do not damage a solder material and insulator fabricating the varistor.
- 4** The following preventive measures should be made for avoiding unexpected accident.
- (1) When using a varistor in between circuits, connect an earth leakage breaker (ground-fault circuit interrupter) or current fuse in series with the varistor.
 - (2) When using a varistor in between a circuit and ground, connect an earth leakage breaker (ground-fault circuit interrupter) or both of a current fuse and thermal fuse in series with the varistor. Also, in case of excessive voltage due to ground short circuit accident, use the varistor with the rated voltage higher than the excessive voltage.
- 5** Store varistors at a temperature of -10 to + 40°C and a relative humidity of less than 75%.
Avoid storing in environment of rapid changes in temperature, direct sunlight, corrosive gas or dust, and store with the varistors packaged and use within 1 year.
Please confirm soldering of the lead wire with the product stored in a long time in more than 1 year.
- 6** Follow safety standards such as Electrical, UL, CSA and so forth, which specify the use of varistors.
- 7** Catalogs
Product specifications in this catalog are subject to change without notice.
Please request and make sure our product specifications before purchase and/or use.
Performance test data in the catalogs show typical values, which are not assured in the catalogs.
- 8** Regarding compliance for EU REACH Regulation
- (1) According to the content of REACH handbook (Guidance on requirements for substances in articles which is published on May 2008), our electronic components are "articles without any intended release". Therefore they are not applicable for "Registration" for EU REACH Regulation Article 7 (1).
Reference: Electrolytic Condenser Investigation Society
"Study of REACH Regulation in EU about Electrolytic Capacitor" (publicized on 13 March 2008)
 - (2) Nippon Chemi-Con develops the products without substance of very high concern(SVHC).
DEHP(CASNo.117-81-7) was contained as some covering material, Nippon Chemi-Con abolished use of DEHP totally at June, 2011.

TNR is a "NEW" metal oxide varistor having steep non-linear V-I characteristics and high discharge current capability, as follows:

◆TNR Features

1. Excellent transient voltage suppression
2. High discharge current capability
3. Wide range of voltage ratings
4. Symmetrical V-I characteristics (Non Polarity)
5. Fast response
6. Steady operation for repeating surge
7. Low temperature coefficient
8. High reliability
9. UL recognized
10. CSA recognized

◆Applications

1. Electronics instrument protection
2. Telephone system protection
3. Relay contact point protection
4. Rectification diode protection
5. SCR protection
6. Reduction of abnormal voltage in high voltage current
7. Switching transistor protection
8. Reduction of switching surge in electromagnetic brake
9. Prevention of error in digital circuit
10. Reduction of noise from an abnormal voltage

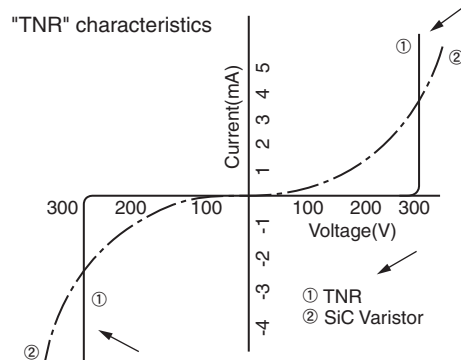

◆Group Chart



◆Part Numbering System

The current parts numbering system is changed to new system for global coding. Your cooperation will be very much appreciated.

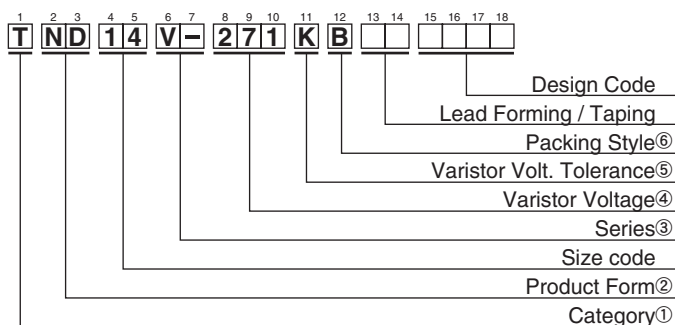

①Category	
T	Metal Oxide Varistors TNR
②Product Form	
ND	Disk Type
NL	Sleeve Type
③Series	
V-	V Series

④Varistor Voltage	
The first two digits are significant figures and the third one denotes the number of following zeros.	
⑤Varistor Volt. Tolerance	
K	±10%
⑥Packing Style	
B	Bulk
T	Taping

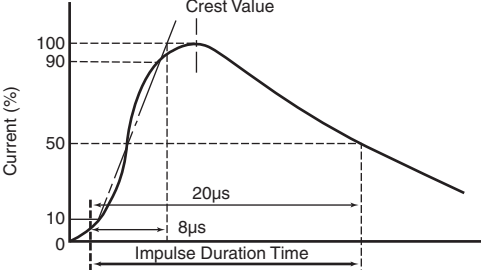
Technical Term	Description
Varistor Voltage	Voltage across the varistor measured at CmA DC. C = 0.1 or 1.0 as specified.
Max. Allowable Voltage (ACrms)	Maximum continuous sinusoidal RMS voltage which may be applied.
Max. Allowable Voltage (DC)	Maximum continuous DC voltage which may be applied.
Maximum Clamping Voltage	Peak voltage across the varistor, measured under conditions of a specified peak impulse current and specified waveform (8/20 μ s) applied 1 time.
Rated Wattage	Maximum power that can be applied within the specified ambient temperature.
Maximum Peak Current	Maximum current within the $\pm 10\%$ varistor voltage change with standard impulse current (8/20 μ s) applied 1 time.
Current Wave Form for Clamping Voltage Test and Maximum Peak Current	 <p>The graph shows a current waveform for a clamping voltage test. The vertical axis represents Current (%) from 0 to 100. The horizontal axis represents Impulse Duration Time. The curve starts at 0, rises to a peak labeled 'Crest Value' at 100% at 8μs, and then decays to 50% at 20μs. Dashed lines indicate the 10% voltage change points at 8μs and 20μs.</p>
Energy	Maximum energy within the $\pm 10\%$ varistor voltage change when 1 impulse τ msec long is applied. $\tau = 2$ or 20 ms as specified.
Capacitance	Typical value measured at a 1kHz test frequency. (Sin wave. Reference purpose only)

SAFETY STANDARDS for V Series
◆TNR V Series / Recognized safety standards

Standards	Category Name	Title	File No.	Varistor Voltage Range
UL1414	FOWX2	Across-the-line Capacitors, Antenna-coupling and Line-bypass Components	E65426	200 ~1800 V
UL1449 3rd. (1)	VZCA2 (USA)	Surge Protective Devices	E323623	82~1800 V
	VZCA8 (Canada)			
CSA C22.2 No.1 Class 2221 01	----	AUDIO AND VIDEO EQUIPMENT- Accessories and Parts for Electronic Equipment Varistor for Across-the-line use as transient protection on 120 V ac	LR-97864	200 ~1800 V
VDE	----	Varistor IEC 61051-1:2007-04 61051-2:1991 61051-2-2:1991	118623	15~1800 V

Recognized Part numbers

Rating	Varistor voltage (V)	Part Number											
		TND05V-***K	TND07V-***K	TND09V-***K	TND10V-***K	TND12V-***K	TND14V-***K	TND20V-***K					
820K	82	○	□	○	□	○	□	○	□	○	□	○	□
101K	100	○	□	○	□	○	□	○	□	○	□	○	□
121K	120	○	□	○	□	○	□	○	□	○	□	○	□
151K	150	○	□	○	□	○	□	○	□	○	□	○	□
181K	180	○	□	○	□	○	□	○	□	○	□	○	□
201K	200	○ ● ☆ □	○ ● ☆ □	○ ● ☆ □	○ ● ☆ □	○ ● ☆ □	○ ● ☆ □	○ ● ☆ □	○ ● ☆ □	○ ● ☆ □	○ ● ☆ □	○ ● ☆ □	○ ● ☆ □
221K	220	○ ● ☆ □	○ ● ☆ □	○ ● ☆ □	○ ● ☆ □	○ ● ☆ □	○ ● ☆ □	○ ● ☆ □	○ ● ☆ □	○ ● ☆ □	○ ● ☆ □	○ ● ☆ □	○ ● ☆ □
241K	240	○ ● ☆ □	○ ● ☆ □	○ ● ☆ □	○ ● ☆ □	○ ● ☆ □	○ ● ☆ □	○ ● ☆ □	○ ● ☆ □	○ ● ☆ □	○ ● ☆ □	○ ● ☆ □	○ ● ☆ □
271K	270	○ ● ☆ □	○ ● ☆ □	○ ● ☆ □	○ ● ☆ □	○ ● ☆ □	○ ● ☆ □	○ ● ☆ □	○ ● ☆ □	○ ● ☆ □	○ ● ☆ □	○ ● ☆ □	○ ● ☆ □
331K	330	○ ● ☆ □	○ ● ☆ □	○ ● ☆ □	○ ● ☆ □	○ ● ☆ □	○ ● ☆ □	○ ● ☆ □	○ ● ☆ □	○ ● ☆ □	○ ● ☆ □	○ ● ☆ □	○ ● ☆ □
361K	360	○ ● ☆ □	○ ● ☆ □	○ ● ☆ □	○ ● ☆ □	○ ● ☆ □	○ ● ☆ □	○ ● ☆ □	○ ● ☆ □	○ ● ☆ □	○ ● ☆ □	○ ● ☆ □	○ ● ☆ □
391K	390	○ ● ☆ □	○ ● ☆ □	○ ● ☆ □	○ ● ☆ □	○ ● ☆ □	○ ● ☆ □	○ ● ☆ □	○ ● ☆ □	○ ● ☆ □	○ ● ☆ □	○ ● ☆ □	○ ● ☆ □
431K	430	○ ● ☆ □	○ ● ☆ □	○ ● ☆ □	○ ● ☆ □	○ ● ☆ □	○ ● ☆ □	○ ● ☆ □	○ ● ☆ □	○ ● ☆ □	○ ● ☆ □	○ ● ☆ □	○ ● ☆ □
471K	470	○ ● ☆ □	○ ● ☆ □	○ ● ☆ □	○ ● ☆ □	○ ● ☆ □	○ ● ☆ □	○ ● ☆ □	○ ● ☆ □	○ ● ☆ □	○ ● ☆ □	○ ● ☆ □	○ ● ☆ □
511K	510		○ ● ☆ □	○ ● ☆ □	○ ● ☆ □	○ ● ☆ □	○ ● ☆ □	○ ● ☆ □	○ ● ☆ □	○ ● ☆ □	○ ● ☆ □	○ ● ☆ □	○ ● ☆ □
561K	560				○ ● ☆ □	○ ● ☆ □	○ ● ☆ □	○ ● ☆ □	○ ● ☆ □	○ ● ☆ □	○ ● ☆ □	○ ● ☆ □	○ ● ☆ □
621K	620				○ ● ☆ □	○ ● ☆ □	○ ● ☆ □	○ ● ☆ □	○ ● ☆ □	○ ● ☆ □	○ ● ☆ □	○ ● ☆ □	○ ● ☆ □
681K	680				○ ● ☆ □	○ ● ☆ □	○ ● ☆ □	○ ● ☆ □	○ ● ☆ □	○ ● ☆ □	○ ● ☆ □	○ ● ☆ □	○ ● ☆ □
751K	750				○ ● ☆ □	○ ● ☆ □	○ ● ☆ □	○ ● ☆ □	○ ● ☆ □	○ ● ☆ □	○ ● ☆ □	○ ● ☆ □	○ ● ☆ □
821K	820				○ ● ☆ □	○ ● ☆ □	○ ● ☆ □	○ ● ☆ □	○ ● ☆ □	○ ● ☆ □	○ ● ☆ □	○ ● ☆ □	○ ● ☆ □
911K	910				○ ● ☆ □	○ ● ☆ □	○ ● ☆ □	○ ● ☆ □	○ ● ☆ □	○ ● ☆ □	○ ● ☆ □	○ ● ☆ □	○ ● ☆ □
102K	1000				○ ● ☆ □	○ ● ☆ □	○ ● ☆ □	○ ● ☆ □	○ ● ☆ □	○ ● ☆ □	○ ● ☆ □	○ ● ☆ □	○ ● ☆ □
112K	1100				○ ● ☆ □	○ ● ☆ □	○ ● ☆ □	○ ● ☆ □	○ ● ☆ □	○ ● ☆ □	○ ● ☆ □	○ ● ☆ □	○ ● ☆ □
122K	1200				○ ● ☆ □	○ ● ☆ □	○ ● ☆ □	○ ● ☆ □	○ ● ☆ □	○ ● ☆ □	○ ● ☆ □	○ ● ☆ □	○ ● ☆ □
152K	1500				○ ● ☆ □	○ ● ☆ □	○ ● ☆ □	○ ● ☆ □	○ ● ☆ □	○ ● ☆ □	○ ● ☆ □	○ ● ☆ □	○ ● ☆ □
182K	1800				○ ● ☆ □	○ ● ☆ □	○ ● ☆ □	○ ● ☆ □	○ ● ☆ □	○ ● ☆ □	○ ● ☆ □	○ ● ☆ □	○ ● ☆ □

***K": Rating

○ : UL1449, ● : UL1414, ☆ : CSA, □ : VDE, ■ : VDE and IEC 60950-1:2005,Annex Q

*Coverage of UL1449

In UL1449, the coverage is prescribed according to surge current as follows.

Type	Equipment where TNR is used	Varistor Rating
Type 3	Cord Connected Direct Plug-In	TND10V(621K-182K), TND12V(431K-182K)
Type 2	Permanently Connected	TND14V(201K-182K), TND20V(820K-182K)
Others	Others	TND05V, TND07V, TND09V, TND10V(820K-561K), TND14V(820K-181K)

*Recognized marking

UL, CSA : on the products VDE : on the package label

◆The AC Rated Voltage and Maximum Allowable Voltage

Rating	Maximum Allowable Voltage		AC Rated Voltage (Vrms)		
	ACrms (V)	DC (V)	UL1414	UL1449	CSA
820K	50	65	N/A	45	N/A
101K	60	85	N/A	55	N/A
121K	75	100	N/A	68	N/A
151K	95	125	N/A	86	N/A
181K	110	145	N/A	100	N/A
201K	130	170	125	118	118
221K	140	180	125	127	127
241K	150	200	125	136	136
271K	175	225	125	159	159
331K	210	270	125	189	189
361K	230	300	125	209	209
391K	250	320	250	227	227
431K	275	350	250	250	250
471K	300	385	250	272	272
511K	315	410	250	286	286
561K	350	460	250	318	318
621K	385	505	250	350	350
681K	420	560	250	381	381
751K	460	615	250	418	418
821K	510	670	250	463	463
911K	550	745	250	500	500
102K	625	825	250	568	568
112K	680	895	250	600	600
122K	720	980	250	600	600
152K	860	1220	250	600	600
182K	1000	1465	250	600	600

◆Application Notes

1) CSA regulate "Maximum Rating Fuse" for using TNR to "Audio, Video and Similar Electronic Equipment" as below

Maximum Peak Current 8/20 μ s, 1 time(A)	Type of TNR	Maximum Rating of Fuse (A)
Up to 500		3
501~2000	TND05V, TND07V	5
2001~6000	TND09V, TND10V, TND12V, TND14V	10
Over 6000	TND20V	Not specified

2) "Rated Voltages" are specified for UL/CSA recognized components besides Maximum Allowable Voltage because of conforming to the Standby Current specified in safety standards.

In case of making an application to UL/CSA approval for equipment with TNR, the maximum AC operating voltage of equipment shall be lower than the TNR Rated Voltage.

SAFETY STANDARDS for SE & SV Series
◆TNR SE & SV Series / Recognized safety standards

Standards	Category Name	Title	File No.	Varistor Voltage Range	Symbol
UL1414	FOWX2	Across-the-line Capacitors, Antenna-coupling and Line-bypass Components	E65426	220~620 V	●
UL1449 3rd. (1)	VZCA2 (USA)	Surge Protective Devices	E323623	220~620 V	○
	VZCA8 (Canada)				
CSA C22.2 No.1 Class 2221 01	----	AUDIO AND VIDEO EQUIPMENT- Accessories and Parts for Electronic Equipment Varistor for Across-the-line use as transient protection on 120 V ac	LR-97864	220~620 V	☆
VDE	----	Varistor IEC 61051-1:2007-04 61051-2:1991 61051-2-2:1991	118623	220~620 V	□

Recognized Part numbers

Rating	Varistor voltage (V)	Part number			
		TND10SE***K TND10SV***K	TND12SE***K TND12SV***K	TND14SE***K TND14SV***K	TND20SE***K
221K	220	○ ● ☆ □		○ ● ☆ ■	○ ● ☆ □
241K	240	○ ● ☆ □		○ ● ☆ ■	○ ● ☆ □
271K	270	○ ● ☆ □		○ ● ☆ ■	○ ● ☆ □
431K	430	○ ● ☆ □	○ ☆ ■	○ ● ☆ ■	○ ● ☆ □
471K	470	○ ● ☆ □	○ ☆ ■	○ ● ☆ ■	○ ● ☆ □
511K	510	○ ● ☆ □	○ ☆ ■	○ ● ☆ ■	○ ● ☆ □
561K	560	○ ● ☆ □	○ ☆ ■	○ ● ☆ ■	○ ● ☆ □
621K	620	○ ● ☆ □	○ ☆ ■	○ ● ☆ ■	○ ● ☆ □

***K": Rating

○ : UL1449, ● : UL1414, ☆ : CSA, □ : VDE, ■ : VDE and IEC 60950-1:2005,Annex Q

***Coverage of UL1449**

In UL1449, the coverage is prescribed according to surge current as follows.

Type	Equipment where TNR is used	Varistor Rating
Type 3	Cord Connected Direct Plug-In	TND10SE(621K), TND12SE(431K-621K) TND10SV(621K), TND12SV(431K-621K)
Type 2	Permanently Connected	TND14SE(221K-621K), TND20SE(221K-621K) TND14SV(221K-621K)
Others	Others	TND10SE(221K-511K) TND10SV(221K-511K)

***Recognized marking**

UL, CSA : on the products VDE : on the package label

● This Specifies the lead forming specifications for Disk Type (V, SE, H series)

◆ FORM

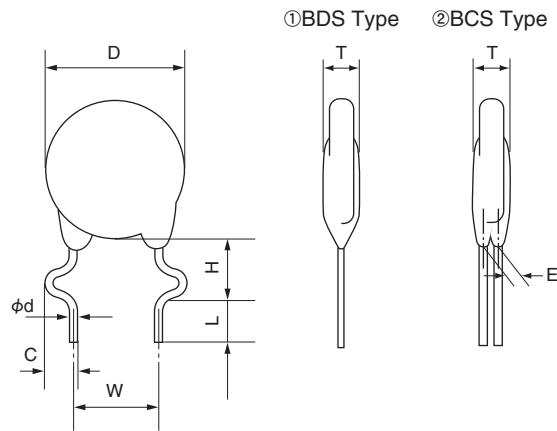

◆ DIMENSIONS

Unit : mm

Type	5V, 7V, 9V, 9H	10V, 12V, 14V, 12H, 15H	20V, 20SE, 23H
Lead style code	BDS	BCS	BCS
D	refer to each spec.	refer to each spec.	refer to each spec.
T	refer to each spec.	refer to each spec.	refer to each spec.
H	6.0 ^{+2.0} -1.0	6.0 ^{+2.0} -1.0	6.0 ^{+2.0} -1.0
L	5.0±1.0	5.0±1.0	5.0±1.0
W	5.0±1.0	7.5±1.0	10.0±1.0
φd	0.6±0.05	0.8±0.05	0.8±0.05
C	2.0±0.5	2.0±0.5	2.0±0.5
E	—	refer to each spec.	refer to each spec.

◆ PART NUMBERING SYSTEM (BULK)

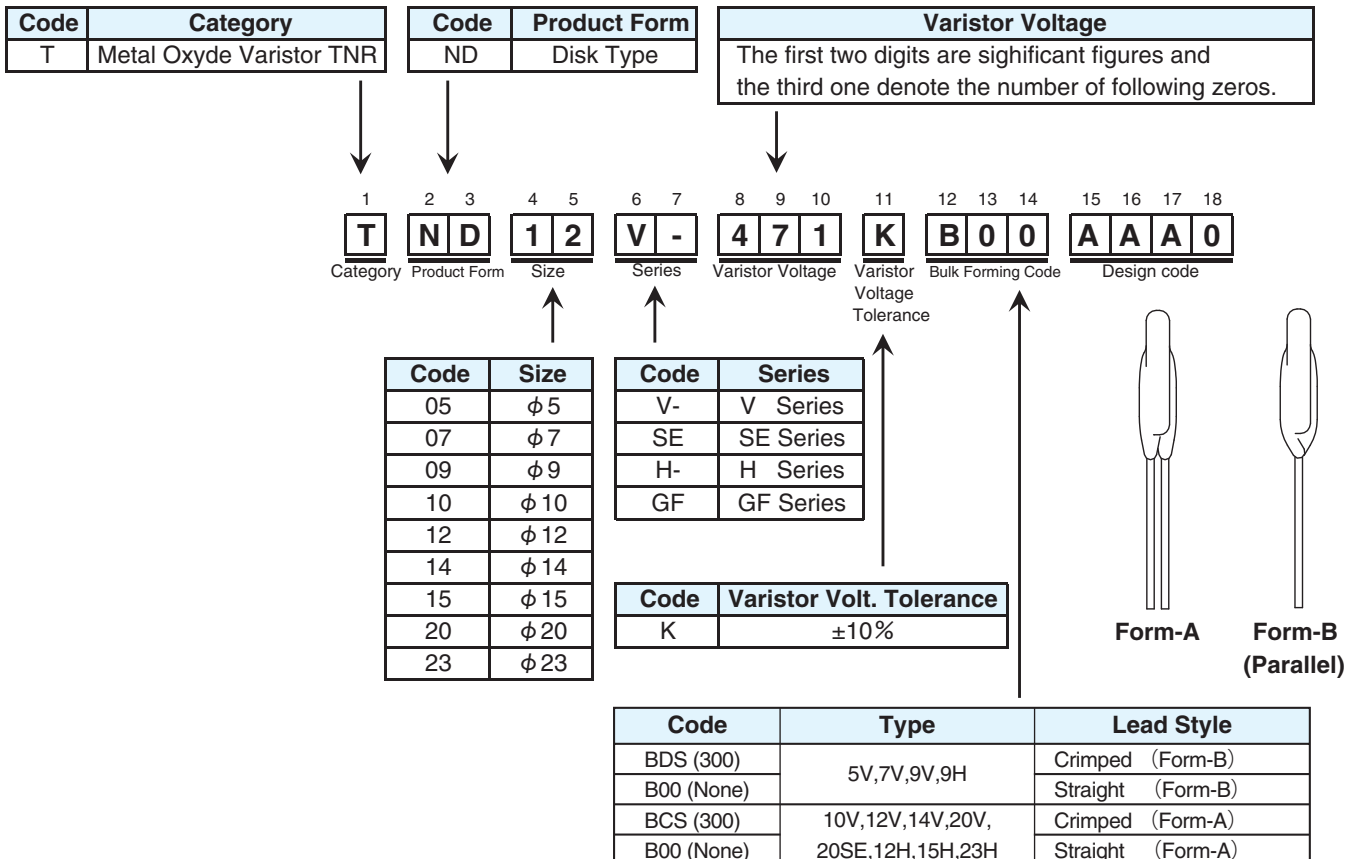

Note : The Code (300) is the Previous Code.

- This Specifies taping specifications for TNR varistors which have normal disk diameter of 5 to 15mm and nominal varistor voltage of 15 to 510V.
- These taping specifications conform to JIS C 0805.

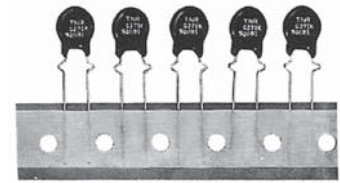

◆PART NUMBERING SYSTEM

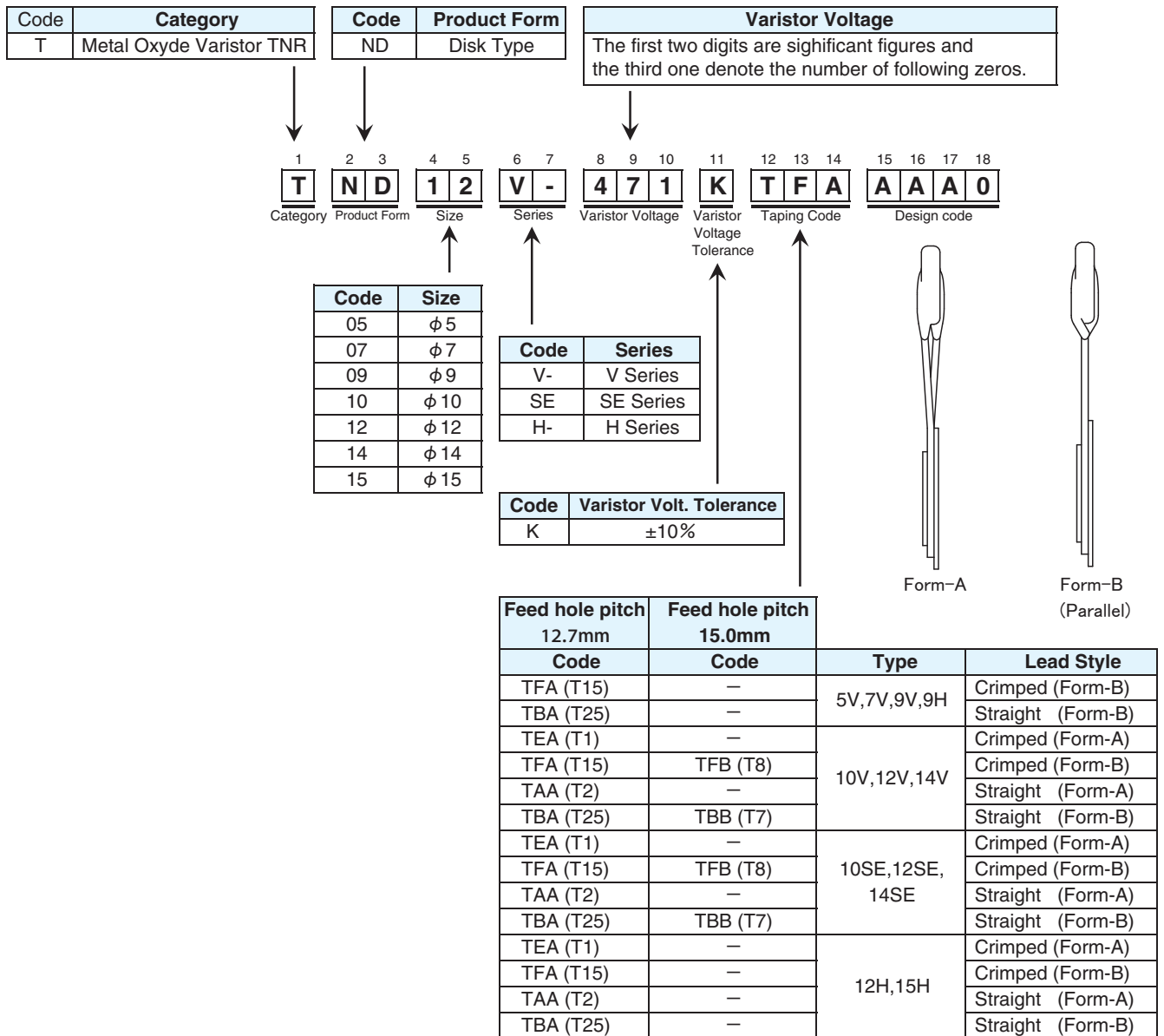

Note : The Code (T1,T15,T2,T25,T8,T7) are the old taping code.

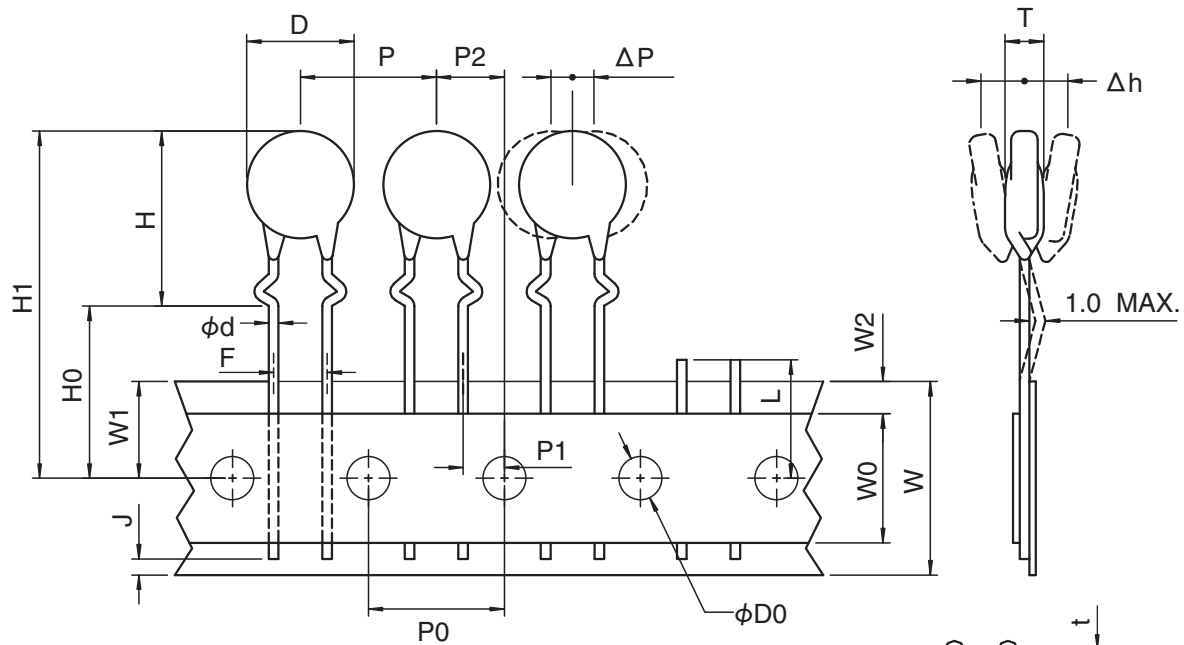
◆5V, 7V, 9V, 9H : TYPE TFA(T15) (Crimped Lead)

Type	5V	7V	9V	9H
Height (H Max.)	13.0	14.5	17.5	16.0
Component Height (H1 Max.)	30.0	31.0	34.0	33.0

◆TYPE TFA(T15)

Parameter	Code	Dimensions (mm)	Note
Diameter of component	D	—	Refer to the applicable detail spec
Thickness of component	T	—	Refer to the applicable detail spec
Lead diameter	φd	0.6±0.05	
Pitch of component	P	12.7±1.0	
Feed hole pitch	P0	12.7±0.3	Cumulative pitch error : ±1 mm/20 pitches
Feed hole diameter	φD0	4.0±0.2	
Feed hole center to lead	P1	3.85±0.7	Measured at the upper end of tape
Feed hole center to component center	P2	6.35±1.3	
Feed hole position	W1	9.0±0.5	
Lead spacing	F	5.0±0.8	
Deviation across tape	Δh	0±2.0	
Deviation along tape	ΔP	0±1.0	
Carrier tape width	W	18.0± ^{0.0} _{0.5}	
Hold down tape width	W0	5.0 Min.	
Total tape thickness	t	0.6±0.3	
Hold down tape position	W2	3.0 Max.	
Seating plane height	H0	16.0±0.5	
Component height	H1	—	Please refer to the above list
Lead position	J	6.0 Max.	
Defective article cut position	L	11.0 Max.	

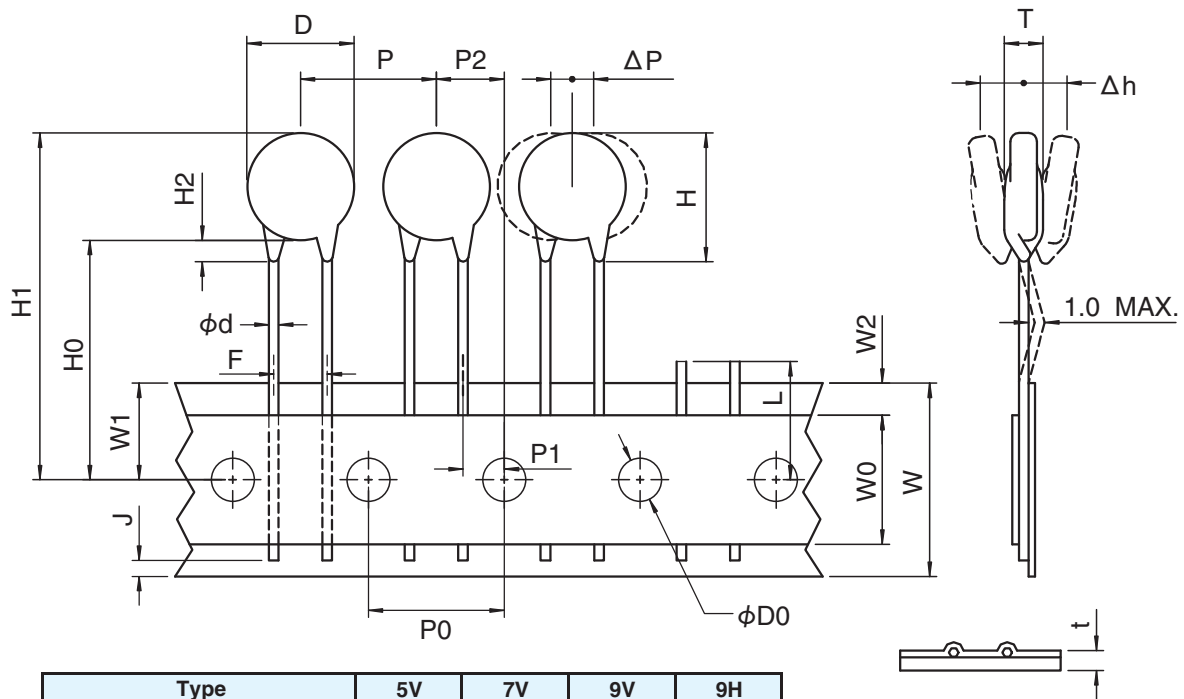
◆ 5V, 7V, 9V, 9H : TYPE TBA(T25) (Straight Lead)

Type	5V	7V	9V	9H
Height (H Max.)	10.0	11.5	14.5	14.0
Component Height (H1 Max.)	29.0	30.0	33.0	32.0

◆TYPE TBA(T25)

Parameter	Code	Dimensions (mm)	Note
Diameter of component	D	—	Refer to the applicable detail spec
Thickness of component	T	—	Refer to the applicable detail spec
Lead diameter	φd	0.6±0.05	
Pitch of component	P	12.7±1.0	
Feed hole pitch	P0	12.7±0.3	Cumulative pitch error : ±1 mm/20 pitches
Feed hole diameter	φD0	4.0±0.2	
Feed hole center to lead	P1	3.85±0.7	Measured at the upper end of tape
Feed hole center to component center	P2	6.35±1.3	
Feed hole position	W1	9.0±0.5	
Lead spacing	F	5.0±0.8	
Deviation across tape	Δh	0±2.0	9V : 34.0 Max.
Deviation along tape	ΔP	0±1.0	
Carrier tape width	W	18.0± ^{0.8} _{0.8}	
Hold down tape width	W0	5.0 Min.	
Total tape thickness	t	0.6±0.3	
Hold down tape position	W2	3.0 Max.	
Height from tape center to component base	H0	20.0± ^{0.8} _{0.8}	
Component height	H1	—	Please refer to the above list
	H2	3.0 Max.	
Lead position	J	6.0 Max.	
Defective article cut position	L	11.0 Max.	

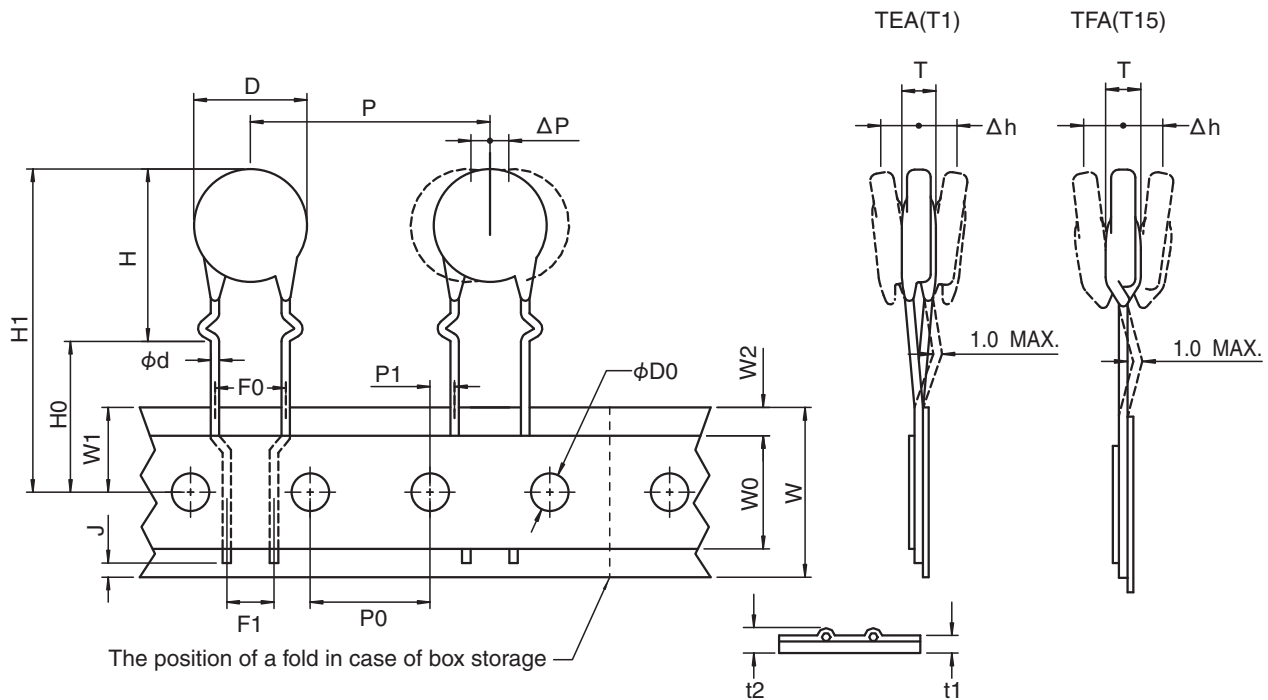
◆10V, 12V, 14V, 10SE, 12SE, 14SE, 12H, 15H : TYPE TEA(T1), TFA(T15) (Crimped Lead)

Type	10V	12V	14V	10SE	12SE	14SE	12H	15H
Height (H Max.)	17.5	19.0	21.0	21.0	24.0	25.0	21.0	24.0
Component Height (H1 Max.)	35.0	36.0	38.0	38.0	41.0	42.0	38.0	41.0

◆TYPE TEA(T1), TFA(T15)

Parameter	Code	Dimensions (mm)	Note
Diameter of component	D	—	Refer to the applicable detail spec
Thickness of component	T	—	Refer to the applicable detail spec
Lead diameter	φd	0.8±0.05	
Pitch of component	P	25.4±1.0	
Feed hole pitch	P0	12.7±0.3	Cumulative pitch error : ±1 mm/20 pitches
Feed hole diameter	φD0	4.0±0.2	
Feed hole center to lead	P1	2.6±0.5	Measured at the upper end of tape
Feed hole position	W1	9.0±0.5	
Lead spacing	F0	7.5±0.8	
	F1	5.0 Nom.	
Deviation across tape	Δh	0±2.0	
Deviation along tape	ΔP	0±1.0	
Carrier tape width	W	18.0 ^{+1.0} _{-0.5}	
Hold down tape width	W0	5.0 Min.	
Total tape thickness	t	0.6±0.3	
Hold down tape position	W2	3.0 Max.	
Seating plane height	H0	16.0±1.0	
Component height	H1	—	Please refer to the above list
Lead position	J	6.0 Max.	

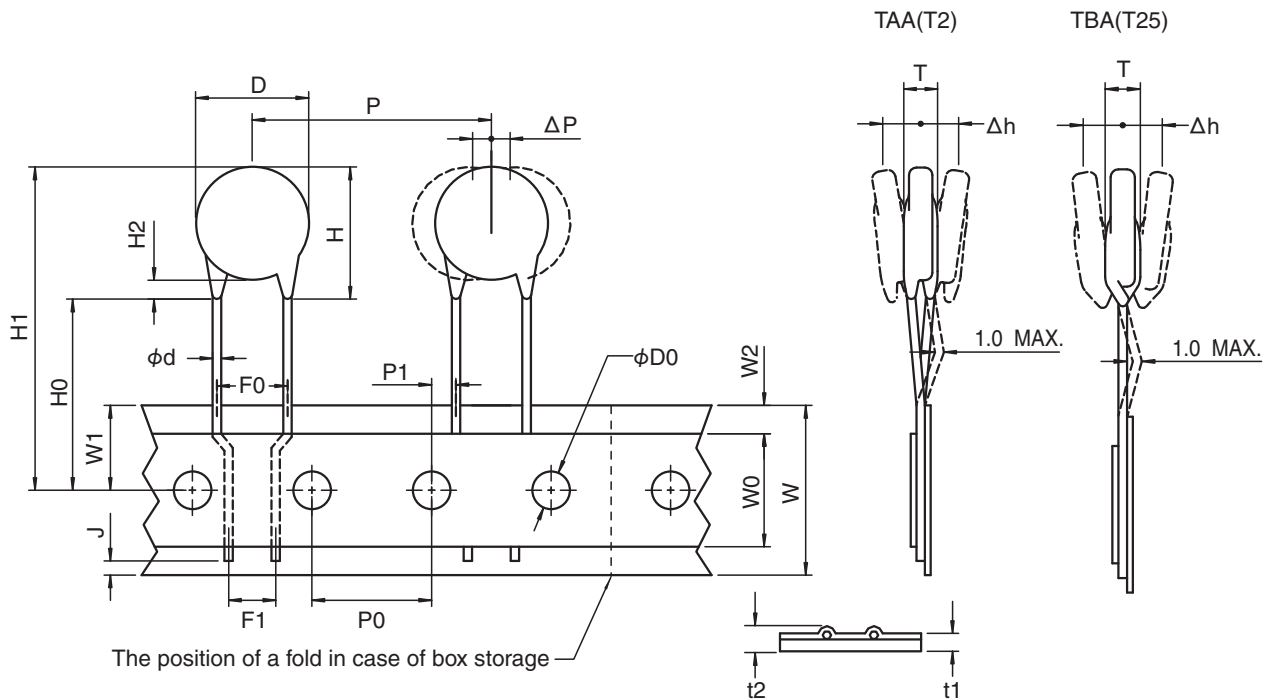
◆10V, 12V, 14V, 10SE, 12SE, 14SE, 12H, 15H : TYPE TAA(T2), TBA(T25) (Straight Lead)

Type	10V	12V	14V	10SE	12SE	14SE	12H	15H
Height (H Max.)	15.5	17.0	19.0	18.5	23.0	24.0	17.0	20.0
Component Height (H1 Max.)	40.0	41.0	43.0	43.0	48.0	49.0	41.0	44.0

◆TYPE TAA(T2), TBA(T25)

Parameter	Code	Dimensions (mm)	Note
Diameter of component	D	—	Refer to the applicable detail spec
Thickness of component	T	—	Refer to the applicable detail spec
Lead diameter	φd	0.8±0.05	
Pitch of component	P	25.4±1.0	
Feed hole pitch	P0	12.7±0.3	Cumulative pitch error : ±1 mm/20 pitches
Feed hole diameter	φD0	4.0±0.2	
Feed hole center to lead	P1	2.6±0.5	Measured at the upper end of tape
Feed hole position	W1	9.0±0.5	
Lead spacing	F0	7.5±0.8	
	F1	5.0 Nom.	
Deviation across tape	Δh	0±2.0	
Deviation along tape	ΔP	0±1.0	
Carrier tape width	W	18.0±0.5	
Hold down tape width	W0	5.0 Min.	
Total tape thickness	t	0.6±0.3	
Hold down tape position	W2	3.0 Max.	
Height from tape center to component base	H0	20.0 Min.	SE : 19.0 Min.
Component height	H1	—	Please refer to the above list
	H2	3.0 Max.	
Lead position	J	6.0 Max.	

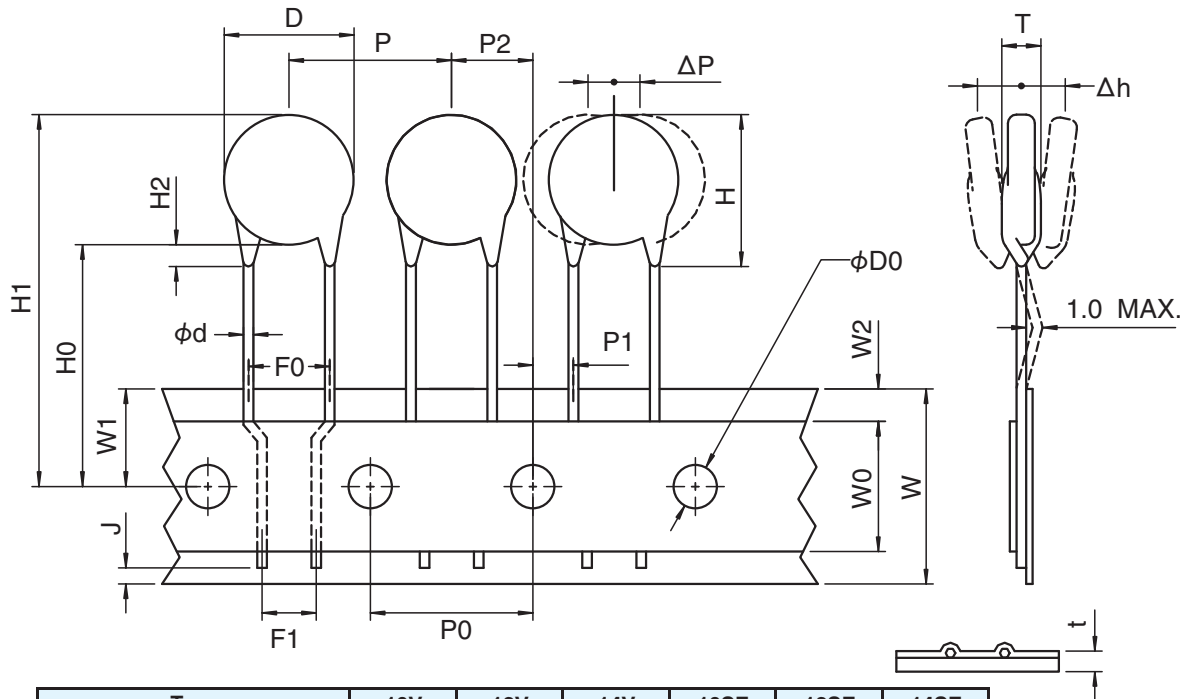
◆10V, 12V, 14V, 10SE, 12SE, 14SE : TYPE TBB(T7) (Straight Lead, 15mm Pitch)

Type	10V	12V	14V	10SE	12SE	14SE
Height (H Max.)	15.5	17.0	19.0	18.5	23.0	24.0
Component Height (H1 Max.)	37.0	39.0	41.0	40.0	45.0	46.0

◆TYPE TBB(T7)

Parameter	Code	Dimensions (mm)	Note
Diameter of component	D	—	Refer to the applicable detail spec (14V : 15.0 Max.)
Thickness of component	T	—	Refer to the applicable detail spec
Lead diameter	φd	0.8±0.05	
Pitch of component	P	15.0±1.0	14SE : 30.0 ±1.0 mm
Feed hole pitch	P0	15.0±0.3	Cumulative pitch error : ±1 mm/20 pitches
Feed hole diameter	φD0	4.0±0.2	
Feed hole center to lead	P1	3.75±0.5	Measured at the upper end of tape
Feed hole center to component center	P2	7.5±1.3	
Feed hole position	W1	9.0±0.5	
Lead spacing	F0	7.5±0.8	
	F1	5.0 Nom.	
Deviation across tape	Δh	0±2.0	
Deviation along tape	ΔP	0±1.3	
Carrier tape width	W	18.0± ^{1.0} _{0.5}	
Hold down tape width	W0	5.0 Min.	
Total tape thickness	t	0.6±0.3	
Hold down tape position	W2	3.0 Max.	
Height from tape center to component base	H0	20.0± ^{1.5} _{1.0}	
Component height	H1	—	Please refer to above list
	H2	3.0 Max.	
Lead position	J	6.0 Max.	

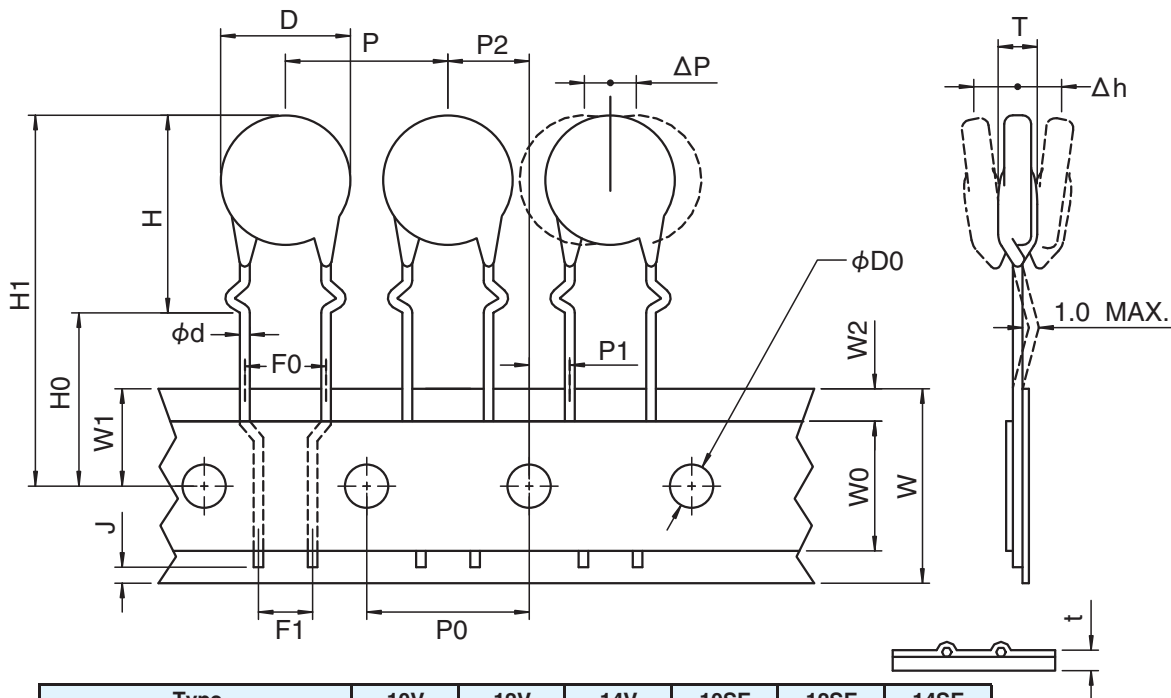
◆10V, 12V, 14V, 10SE, 12SE, 14SE : TYPE TFB(T8) (Crimped Lead, 15mm Pitch)

Type	10V	12V	14V	10SE	12SE	14SE
Height (H Max.)	17.5	19.0	21.0	21.0	24.0	25.0
Component Height (H1 Max.)	35.0	36.0	38.0	38.0	41.0	42.0

◆TYPE TFB(T8)

Parameter	Code	Dimensions (mm)	Note
Diameter of component	D	—	Refer to the applicable detail spec (14V : 15.0 Max.)
Thickness of component	T	—	Refer to the applicable detail spec
Lead diameter	φd	0.8±0.05	
Pitch of component	P	15.0±1.0	14SE : 30.0±1.0 mm
Feed hole pitch	P0	15.0±0.3	Cumulative pitch error : ±1 mm/20 pitches
Feed hole diameter	φD0	4.0±0.2	
Feed hole center to lead	P1	3.75±0.5	Measured at the upper end of tape
Feed hole center to component center	P2	7.5±1.3	
Feed hole position	W1	9.0±0.5	
Lead spacing	F0	7.5±0.8	
	F1	5.0 Nom.	
Deviation across tape	Δh	0±2.0	
Deviation along tape	ΔP	0±1.3	
Carrier tape width	W	18.0±0.5	
Hold down tape width	W0	5.0 Min.	
Total tape thickness	t	0.6±0.3	
Hold down tape position	W2	3.0 Max.	
Seating plane height	H	—	10V ; 17.5 Max. 14V ; 21.0 Max.
	H0	16.0±1.0	
Component height	H1	—	Please refer to above list
Lead position	J	6.0 Max.	

◆Packaging

		B o x			
Configuration					
Dimensions (mm)		TFA, TBA (T15, T25)	TEA, TFA, TAA, TBA (T1, T15, T2, T25)		TFB, TBB, TLB (T8, T7, T71)
		5V, 7V, 9V, 9H	10V, 12V, 14V, 12H, 15H	10SE, 12SE, 14SE	10V, 12V, 10SE, 12SE, 14SE, 10SV, 12SV, 14SV
	W	325±5	330±5	340 max.	340 max.
	H	47±3	57±3	65 max.	65 max.
	B	280±10	315±10	360 max.	360 max.

◆Packaging Quantity

Type	Taping Code	150K~271K	331K~621K
5V,7V,9V,9H	TFA, TBA(T15, T25)	1500	1000
10V,12V,14V	TEA, TFA, TAA, TBA (T1, T15, T2, T25)	800	500
10SE,12SE,14SE		600	500
12H,15H		800	500
10V,12V,14V	TFB, TBB (T8, T7)	1000	1000
10SE		1000	800
12SE,14SE		500	400
10SV,12SV	TLB (T71)	500	500
14SV		300	300

NOTE : The code (T1, T15, T2, T25, T8, T7) are the old taping code

◆Others

- 1) On the box or the reel, the following are noted.
 1. Part number
 2. Lot number
 3. Quantity
 4. Country of origin
- 2) Minimum order quantity shall be the packaging quantity per one box one reel.

MINIMUM ORDER QUANTITY

Please order by units of minimum order quantity.

◆Disk Type

Series	Type	Varistor Voltage Range (V)	Straight Lead Quantity (pcs)	Formed/Cut Lead Quantity (pcs)
V	5V, 7V, 9V	All Voltage Range	100	100
	10V, 12V	All Voltage Range	100	100
	14V	15~1200	100	100
		1500~1800	50	50
	20V	18~1100	50	50
1200~1800		25	25	
SE	20SE	All Voltage Range	50	50
H	9H, 12H, 15H	All Voltage Range	100	100
	23H	All Voltage Range	50	50
GF	15GF	All Voltage Range	50	—
	23GF	All Voltage Range	25	—
32HP	—	All Voltage Range	5	—

◆Axial Lead Type

Series	Type	Varistor Voltage Range (V)	Straight Lead Quantity (pcs)	Formed/Cut Lead Quantity (pcs)
A	4A	All Voltage Range	100	—
	10A	All Voltage Range	50	—

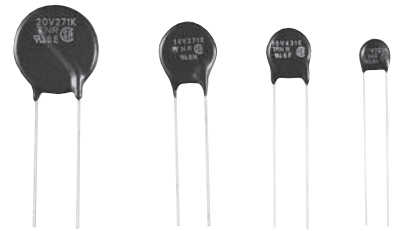

◆FEATURES

- Large surge capability (the surge current ratings of TNR V series, by 8/20 μs, are about two times larger than TNR G series).
- Large energy capability (1.5 time larger than TNR G series).
- One rank smaller TNR V has same peak current as TNR G.
- Excellent voltage non-linear coefficient.
Low clamping voltage.
- Symmetrical V-I characteristics (No polarity).
- Fast response.
- Stable characteristics against repeated surges.
- Superior temperature characteristics.
- High reliability
- UL, CSA and VDE recognized components
UL 1449 3rd File : E323623
UL 1414 File : E65426 (Except "12V")
CSA File : LR97864
VDE File : 118623

◆APPLICATIONS

- Protection for semiconductors from over voltage.
- Protection for electronic instruments from lightning surges.
- Absorption of on-off surges from motors and relays.

Operating Temperature Range: -40 to +85°C
Storage Temperature Range: -50 to +125°C

◆PART NUMBERING SYSTEM

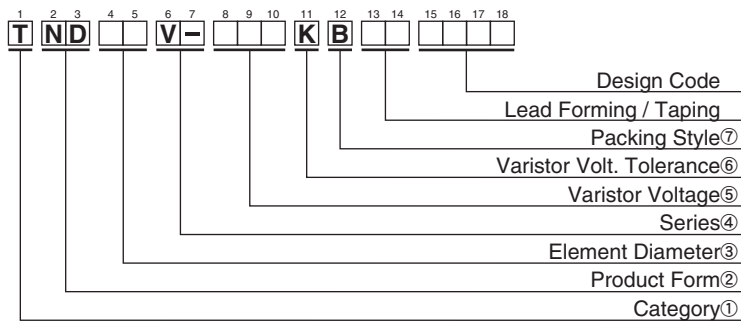

①Category	
T	Metal Oxide Varistors TNR

②Product Form	
ND	Disk Type

③Element Diameter	
05	φ 5 mm
07	φ 7 mm
09	φ 9 mm
10	φ10 mm
12	φ12 mm
14	φ14 mm
20	φ20 mm

④Series	
V-	V Series

⑤Varistor Voltage	
The first two digits are significant figures and the third one denotes the number of following zeros.	

⑥Varistor Volt. Tolerance	
K	±10%

⑦Packing Style	
B	Bulk
T	Taping



V Series

◆STANDARD RATINGS (Type 5V)

Part Number	Previous Part Number (Just for your reference)	Maximum Ratings					Max. Clamping Voltage		Capacitance Typical @1kHz (pF)	Varistor Voltage V _{0.1mA} (V)	T Max. (mm)
		Max. Allowable Voltage		Max. Peak Current	Max. Energy	Rated Wattage	(A)	(V)			
		AC (Vrms)	DC (V)	8/20μs(A)	2ms(J)	(W)					
TND05V-180KB00AAA	TNR5V180K	11	14	250A/1 time 125A/2 times	0.4	0.01	1	40	2540	18 (16~ 20)	4.5
TND05V-220KB00AAA	TNR5V220K	14	18		0.5			48	2090	22 (20~ 24)	
TND05V-270KB00AAA	TNR5V270K	17	22		0.7			60	1790	27 (24~ 30)	
TND05V-330KB00AAA	TNR5V330K	20	26		0.8			73	1480	33 (30~ 36)	
TND05V-390KB00AAA	TNR5V390K	25	30		0.9			86	1310	39 (35~ 43)	
TND05V-470KB00AAA	TNR5V470K	30	37		1.1			104	1140	47 (42~ 52)	
TND05V-560KB00AAA	TNR5V560K	35	44		1.3			123	1000	56 (50~ 62)	
TND05V-680KB00AAA	TNR5V680K	40	55	1.6	150	870	68 (61~ 75)				
TND05V-820KB00AAA	TNR5V820K	50	65	800A/1 time 600A/2 times	2.5	0.1	5	145	400	82 (74~ 90)	4.1
TND05V-101KB00AAA	TNR5V101K	60	85		3			175	350	100 (90~110)	4.3
TND05V-121KB00AAA	TNR5V121K	75	100		3.5			210	310	120 (108~132)	4.5
TND05V-151KB00AAA	TNR5V151K	95	125		4.5			260	270	150 (135~165)	4.8
TND05V-181KB00AAA	TNR5V181K	110	145		5			325	190	180 (162~198)	4.3
TND05V-201KB00AAA	TNR5V201K	130	170		6			355	110	200 (185~225)	4.4
TND05V-221KB00AAA	TNR5V221K	140	180		6.5			380	110	220 (198~242)	4.5
TND05V-241KB00AAA	TNR5V241K	150	200		7.5			415	100	240 (216~264)	4.6
TND05V-271KB00AAA	TNR5V271K	175	225		8			475	90	270 (247~303)	4.8
TND05V-331KB00AAA	TNR5V331K	210	270		9.5			570	80	330 (297~363)	5.1
TND05V-361KB00AAA	TNR5V361K	230	300		11			620	80	360 (324~396)	5.3
TND05V-391KB00AAA	TNR5V391K	250	320		12			675	70	390 (351~429)	5.4
TND05V-431KB00AAA	TNR5V431K	275	350		13.5			745	70	430 (387~473)	5.6
TND05V-471KB00AAA	TNR5V471K	300	385		15			810	60	470 (423~517)	5.8

◆DIMENSIONS [mm]

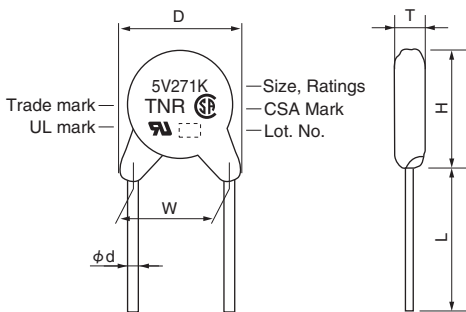

D Max.	H Max.	T Max.	L Min.	φd ±0.05	W ±1.0
7.5	10.0	Ref. to RATINGS	20.0	0.6	5.0

◆V-I CURVE

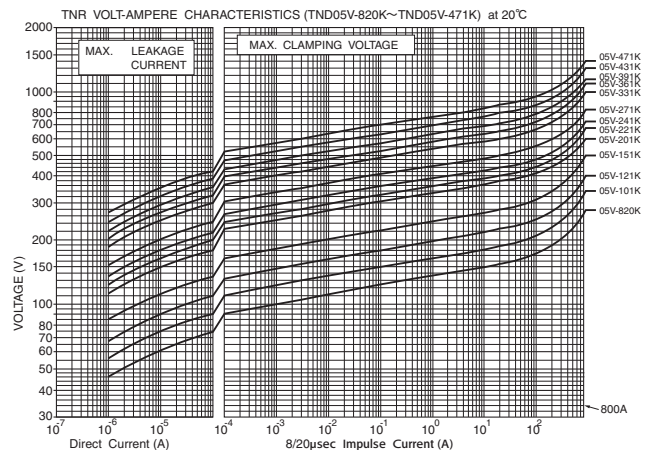
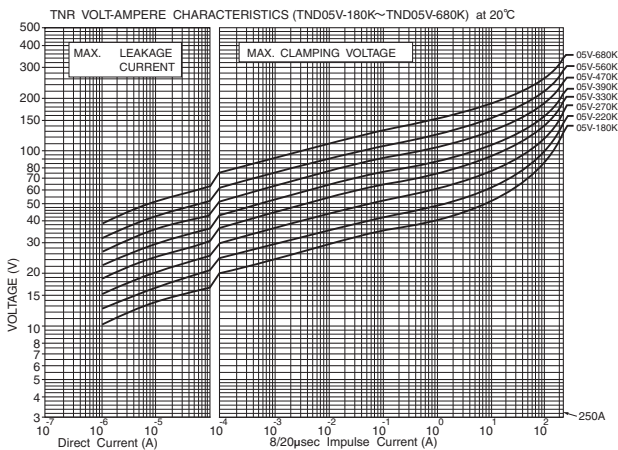



V Series

◆STANDARD RATINGS (Type 7V)

Part Number	Previous Part Number (Just for your reference)	Maximum Ratings					Max. Clamping Voltage		Capacitance Typical @1kHz (pF)	Varistor Voltage V _{1mA} (V)	T Max. (mm)
		Max. Allowable Voltage		Max. Peak Current	Max. Energy	Rated Wattage	(A)	(V)			
		AC (Vrms)	DC (V)	8/20μs(A)	2ms(J)						
TND07V-150KB00AAA0	TNR7V150K	8	12		0.7			30	4600	15 (13~ 17)	4.5
TND07V-180KB00AAA0	TNR7V180K	11	14		0.9			36	3800	18 (16~ 20)	4.5
TND07V-220KB00AAA0	TNR7V220K	14	18		1.1			43	3200	22 (20~ 24)	4.6
TND07V-270KB00AAA0	TNR7V270K	17	22	500A/1 time	1.3			53	2800	27 (24~ 30)	4.7
TND07V-330KB00AAA0	TNR7V330K	20	26		1.6	0.02	2.5	65	2300	33 (30~ 36)	4.9
TND07V-390KB00AAA0	TNR7V390K	25	30	250A/2 times	1.9			77	2100	39 (35~ 43)	4.8
TND07V-470KB00AAA0	TNR7V470K	30	37		2.3			93	1900	47 (42~ 52)	4.9
TND07V-560KB00AAA0	TNR7V560K	35	44		2.7			110	1700	56 (50~ 62)	5.0
TND07V-680KB00AAA0	TNR7V680K	40	55		3.3			135	1500	68 (61~ 75)	5.2
TND07V-820KB00AAA0	TNR7V820K	50	65		5			135	800	82 (74~ 90)	4.1
TND07V-101KB00AAA0	TNR7V101K	60	85		6			165	700	100 (90~110)	4.3
TND07V-121KB00AAA0	TNR7V121K	75	100		7			200	650	120 (108~132)	4.5
TND07V-151KB00AAA0	TNR7V151K	95	125		9			250	600	150 (135~165)	4.8
TND07V-181KB00AAA0	TNR7V181K	110	145		11			300	430	180 (162~198)	4.3
TND07V-201KB00AAA0	TNR7V201K	130	170		12.5			340	250	200 (185~225)	4.4
TND07V-221KB00AAA0	TNR7V221K	140	180	1750A/1 time	13.5			360	230	220 (198~242)	4.5
TND07V-241KB00AAA0	TNR7V241K	150	200		15	0.25	10	395	210	240 (216~264)	4.6
TND07V-271KB00AAA0	TNR7V271K	175	225	1250A/2 times	17			455	190	270 (247~303)	4.8
TND07V-331KB00AAA0	TNR7V331K	210	270		20			545	160	330 (297~363)	5.1
TND07V-361KB00AAA0	TNR7V361K	230	300		23			595	150	360 (324~396)	5.3
TND07V-391KB00AAA0	TNR7V391K	250	320		25			650	140	390 (351~429)	5.4
TND07V-431KB00AAA0	TNR7V431K	275	350		27.5			710	130	430 (387~473)	5.6
TND07V-471KB00AAA0	TNR7V471K	300	385		30			775	120	470 (423~517)	5.8
TND07V-511KB00AAA0	TNR7V511K	320	410		32			845	110	510 (459~561)	6.0

◆DIMENSIONS [mm]

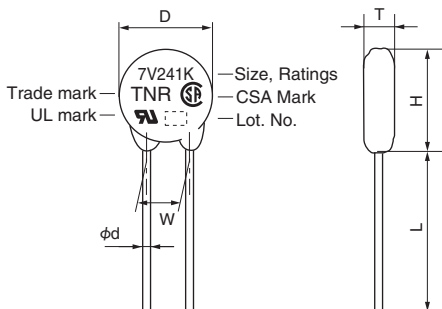

D Max.	H Max.	T Max.	L Min.	φd ±0.05	W ±1.0
8.5	11.5	Ref. to RATINGS	20.0	0.6	5.0

V Series

◆V-I CURVE (Type 7V)

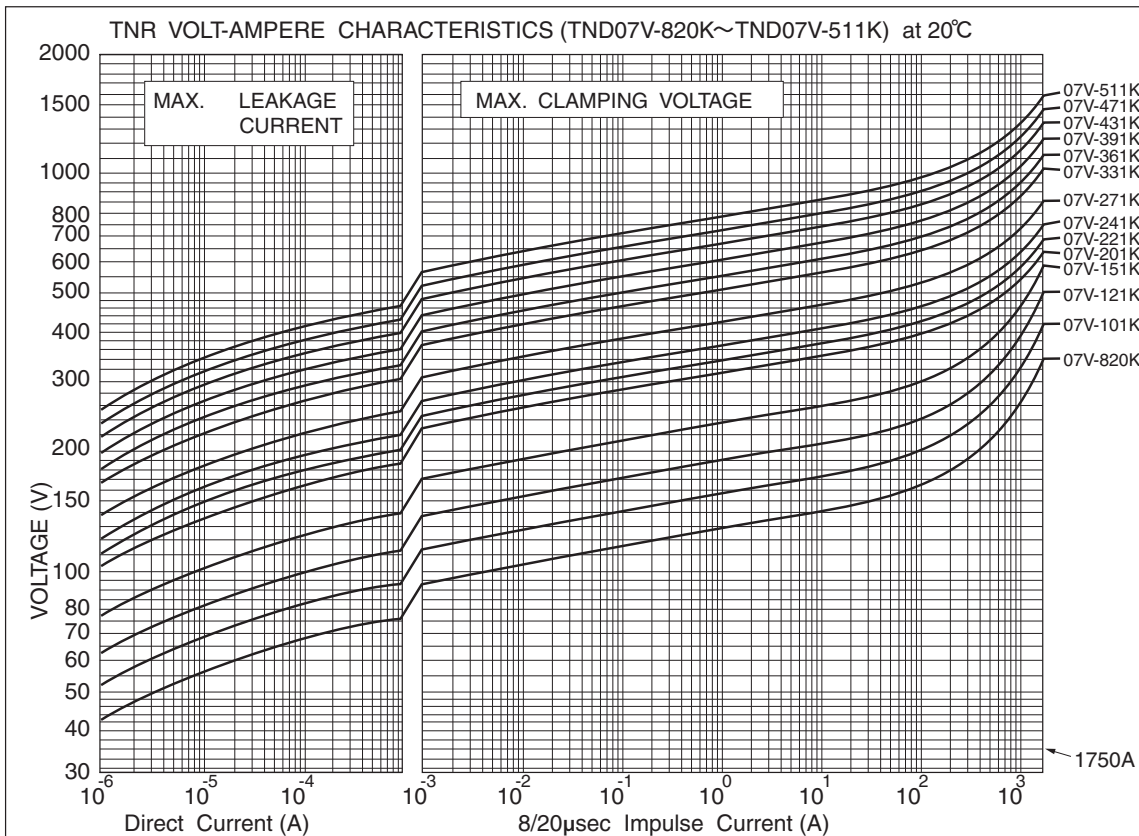
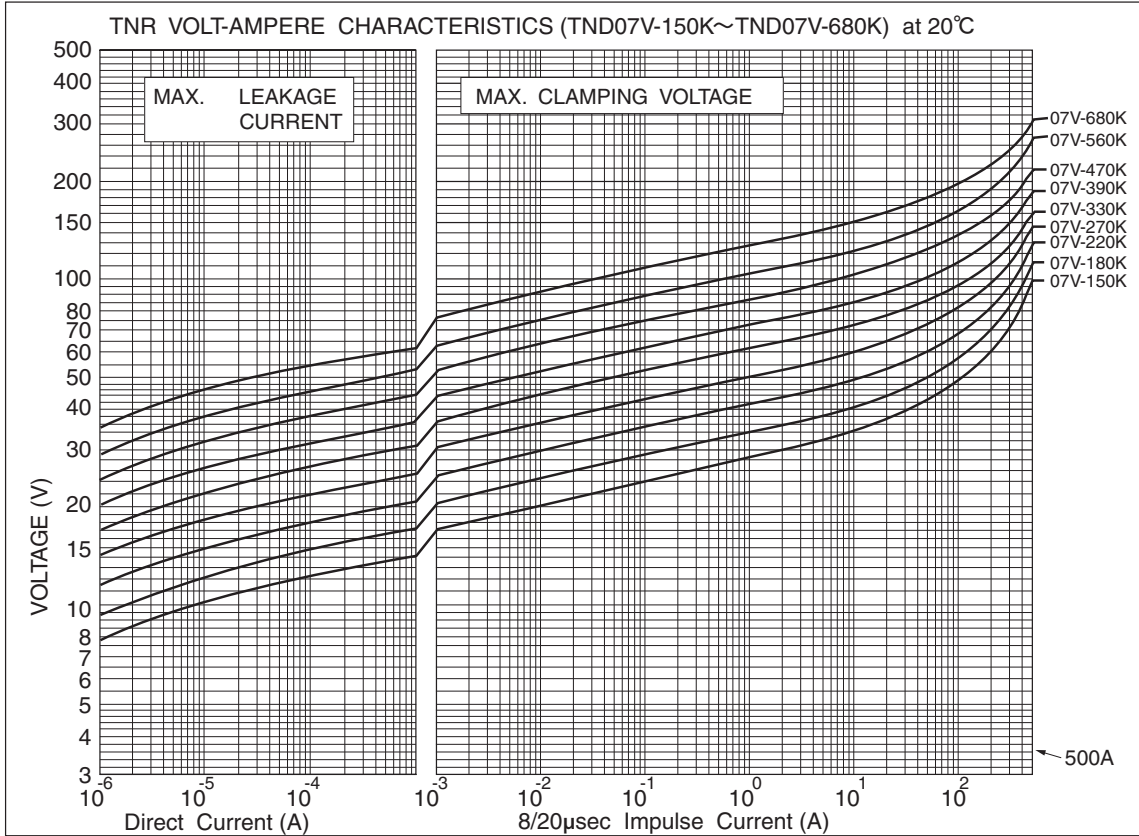



V Series

◆ RATINGS (Type 9V)

Part Number	Previous Part Number (Just for your reference)	Maximum Ratings					Max. Clamping Voltage		Capacitance Typical @1kHz (pF)	Varistor Voltage V _{1mA} (V)	T Max. (mm)
		Max. Allowable Voltage		Max. Peak Current	Max. Energy	Rated Wattage	(A)	(V)			
		AC (Vrms)	DC (V)	8/20μs(A)	2ms(J)						
TND09V-150KB00AAA0	TNR9V150K	8	12		2.0			30	9600	15 (13~ 17)	3.8
TND09V-180KB00AAA0	TNR9V180K	11	14		2.2			36	8000	18 (16~ 20)	3.8
TND09V-220KB00AAA0	TNR9V220K	14	18		2.6			43	7000	22 (20~ 24)	4.0
TND09V-270KB00AAA0	TNR9V270K	17	22	800A/1 time	3.2			53	6000	27 (24~ 30)	4.2
TND09V-330KB00AAA0	TNR9V330K	20	26		4.0	0.02	5	65	5000	33 (30~ 36)	4.5
TND09V-390KB00AAA0	TNR9V390K	25	30	400A/2 times	4.7			77	4500	39 (35~ 43)	4.0
TND09V-470KB00AAA0	TNR9V470K	30	37		5.6			93	4000	47 (42~ 52)	4.2
TND09V-560KB00AAA0	TNR9V560K	35	44		6.7			110	3500	56 (50~ 62)	4.4
TND09V-680KB00AAA0	TNR9V680K	40	55		8.2			135	3200	68 (61~ 75)	4.5
TND09V-820KB00AAA0	TNR9V820K	50	65		10			135	1700	82 (74~ 90)	3.8
TND09V-101KB00AAA0	TNR9V101K	60	85		12			165	1600	100 (90~110)	3.9
TND09V-121KB00AAA0	TNR9V121K	75	100		14.5			200	1400	120 (108~132)	4.1
TND09V-151KB00AAA0	TNR9V151K	95	125		18			250	1300	150 (135~165)	4.4
TND09V-181KB00AAA0	TNR9V181K	110	145		22			300	900	180 (162~198)	4.0
TND09V-201KB00AAA0	TNR9V201K	130	170		25			340	500	200 (185~225)	4.1
TND09V-221KB00AAA0	TNR9V221K	140	180	3000A/1 time	27.5			360	450	220 (198~242)	4.2
TND09V-241KB00AAA0	TNR9V241K	150	200		30	0.25	25	395	400	240 (216~264)	4.3
TND09V-271KB00AAA0	TNR9V271K	175	225	2000A/2 times	35			455	350	270 (247~303)	4.5
TND09V-331KB00AAA0	TNR9V331K	210	270		42			545	300	330 (297~363)	4.8
TND09V-361KB00AAA0	TNR9V361K	230	300		45			595	280	360 (324~396)	5.0
TND09V-391KB00AAA0	TNR9V391K	250	320		50			650	260	390 (351~429)	5.1
TND09V-431KB00AAA0	TNR9V431K	275	350		55			710	240	430 (387~473)	5.3
TND09V-471KB00AAA0	TNR9V471K	300	385		60			775	220	470 (423~517)	5.6
TND09V-511KB00AAA0	TNR9V511K	320	410		67			845	210	510 (459~561)	5.8

◆ DIMENSIONS [mm]

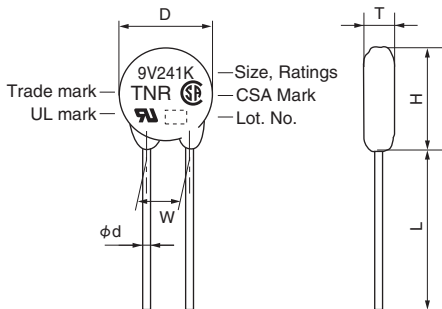

D Max.	H Max.	T Max.	L Min.	φd ±0.05	W ±1.0
11.5	14.5	Ref. to RATINGS	20.0	0.6	5.0



V Series

◆V-I CURVE (Type 9V)

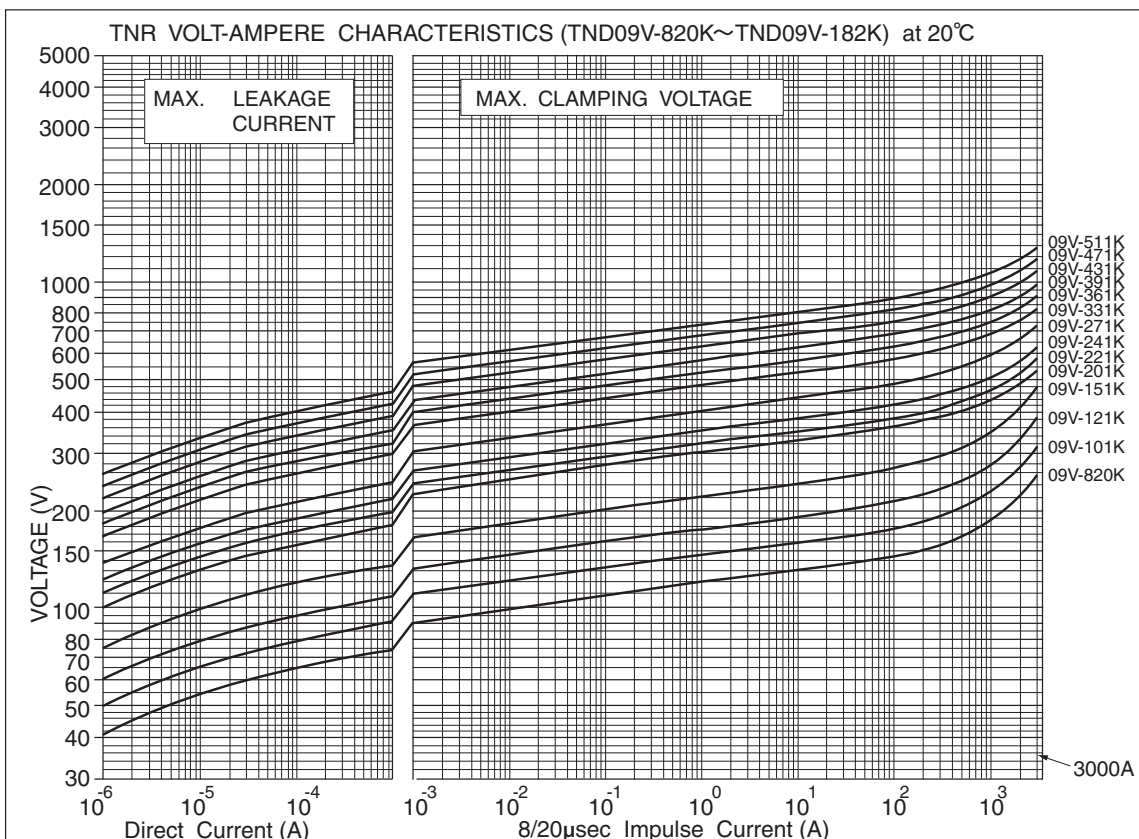
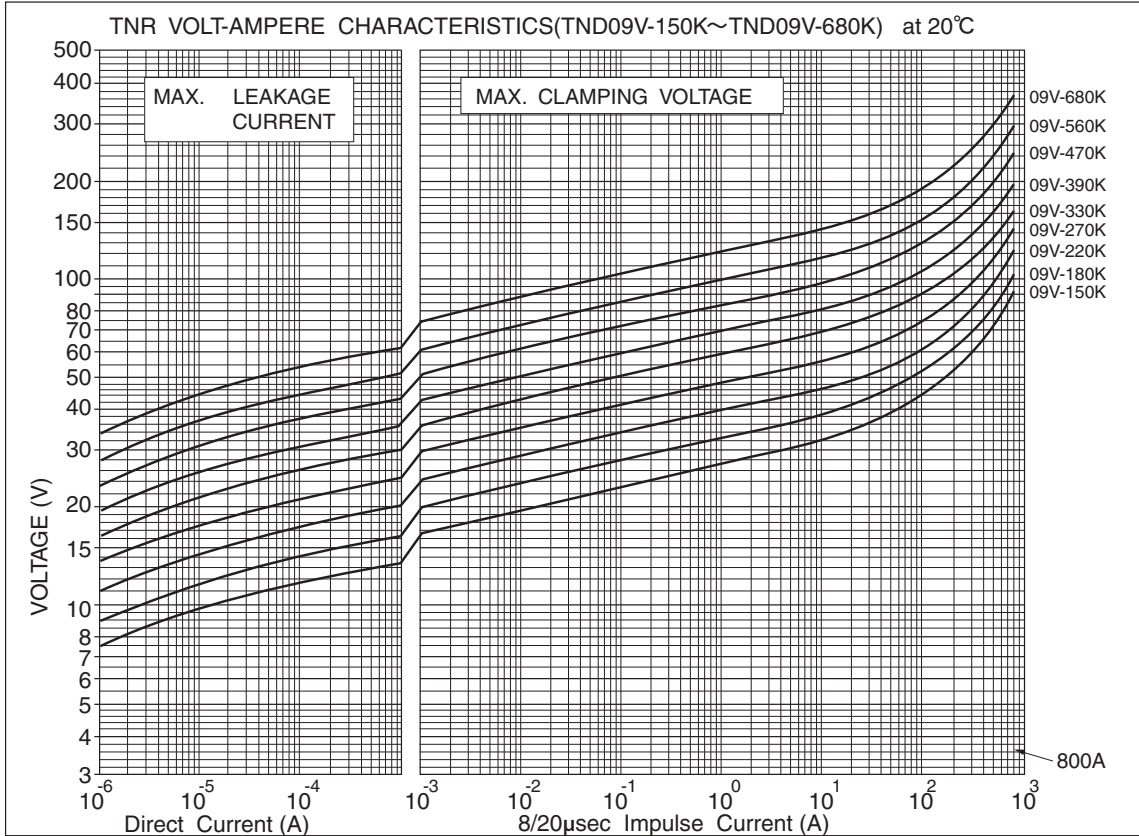

V Series

◆RATINGS (Type 10V)

Part Number	Previous Part Number (Just for your reference)	Maximum Ratings					Max. Clamping Voltage		Capacitance Typical @1kHz	Varistor Voltage V1mA	T Max.	E ±1.0	W2 reference
		Max. Allowable Voltage		Max. Peak Current	Max. Energy	Rated Wattage	(A)	(V)					
		AC (Vrms)	DC (V)	8/20μs(A)	2ms(J)	(W)			(pF)	(V)	(mm)	(mm)	(mm)
TND10V-150KB00AAA0	TNR10V150K	8	12		2.0			30	9600	15 (13~ 17)	4.5	1.0	7.6
TND10V-180KB00AAA0	TNR10V180K	11	14		2.2			36	8000	18 (16~ 20)	4.6	1.1	7.6
TND10V-220KB00AAA0	TNR10V220K	14	18		2.6			43	7000	22 (20~ 24)	4.7	1.2	7.6
TND10V-270KB00AAA0	TNR10V270K	17	22	1000A/1 time	3.2			53	6000	27 (24~ 30)	4.8	1.3	7.6
TND10V-330KB00AAA0	TNR10V330K	20	26		4.0	0.05	5	65	5000	33 (30~ 36)	5.0	1.5	7.6
TND10V-390KB00AAA0	TNR10V390K	25	30	500A/2 times	4.7			77	4500	39 (35~ 43)	4.9	1.3	7.6
TND10V-470KB00AAA0	TNR10V470K	30	37		5.6			93	4000	47 (42~ 52)	5.0	1.4	7.6
TND10V-560KB00AAA0	TNR10V560K	35	44		6.7			110	3500	56 (50~ 62)	5.1	1.6	7.7
TND10V-680KB00AAA0	TNR10V680K	40	55		8.2			135	3200	68 (61~ 75)	5.3	1.8	7.7
TND10V-820KB00AAA0	TNR10V820K	50	65		10			135	1700	82 (74~ 90)	4.5	1.1	7.6
TND10V-101KB00AAA0	TNR10V101K	60	85		12			165	1600	100 (90~ 110)	4.7	1.3	7.6
TND10V-121KB00AAA0	TNR10V121K	75	100		14.5			200	1400	120 (108~ 132)	4.9	1.4	7.6
TND10V-151KB00AAA0	TNR10V151K	95	125		18			250	1300	150 (135~ 165)	5.2	1.7	7.7
TND10V-181KB00AAA0	TNR10V181K	110	145		22			300	900	180 (162~ 198)	4.7	1.1	7.6
TND10V-201KB00AAA0	TNR10V201K	130	170		25			340	500	200 (185~ 225)	4.8	1.2	7.6
TND10V-221KB00AAA0	TNR10V221K	140	180		27.5			360	450	220 (198~ 242)	4.9	1.3	7.6
TND10V-241KB00AAA0	TNR10V241K	150	200		30			395	400	240 (216~ 264)	5.0	1.3	7.6
TND10V-271KB00AAA0	TNR10V271K	175	225		35			455	350	270 (247~ 303)	5.2	1.4	7.6
TND10V-331KB00AAA0	TNR10V331K	210	270		42			545	300	330 (297~ 363)	5.5	1.6	7.7
TND10V-361KB00AAA0	TNR10V361K	230	300		45			595	280	360 (324~ 396)	5.7	1.8	7.7
TND10V-391KB00AAA0	TNR10V391K	250	320	3500A/1 time	50			650	260	390 (351~ 429)	5.8	1.9	7.7
TND10V-431KB00AAA0	TNR10V431K	275	350		55	0.4	25	710	240	430 (387~ 473)	6.0	2.0	7.8
TND10V-471KB00AAA0	TNR10V471K	300	385	2500A/2 times	60			775	220	470 (423~ 517)	6.2	2.1	7.8
TND10V-511KB00AAA0	TNR10V511K	320	410		67			845	210	510 (459~ 561)	6.4	2.3	7.8
TND10V-561KB00AAA0	TNR10V561K	350	460		67			922	195	560 (504~ 616)	6.7	2.5	7.9
TND10V-621KB00AAA0	TNR10V621K	385	505		67			1025	180	620 (558~ 682)	7.1	2.7	8.0
TND10V-681KB00AAA0	TNR10V681K	420	560		67			1120	165	680 (612~ 748)	7.4	2.9	8.0
TND10V-751KB00AAA0	TNR10V751K	460	615		70			1240	150	750 (675~ 825)	7.8	3.1	8.1
TND10V-821KB00AAA0	TNR10V821K	510	670		80			1355	140	820 (738~ 902)	8.1	3.4	8.2
TND10V-911KB00AAA0	TNR10V911K	550	745		90			1500	125	910 (819~1001)	8.6	3.7	8.4
TND10V-102KB00AAA0	TNR10V102K	625	825		100			1650	115	1000 (900~1100)	9.1	4.0	8.5
TND10V-112KB00AAA0	TNR10V112K	680	895		110			1815	105	1100 (990~1210)	9.7	4.4	8.7
TND10V-122KB00AAA0	TNR10V122K	720	980		120			1950	95	1200 (1080~1320)	10.5	4.7*	8.9**
TND10V-152KB00AAA0	TNR10V152K	860	1220		150			2440	85	1500 (1350~1650)	12.4	5.8*	9.5**
TND10V-182KB00AAA0	TNR10V182K	1000	1465		183			2970	70	1800 (1700~1980)	14.4	6.9*	10.2**

*E±2 **W2±2

◆DIMENSIONS [mm]

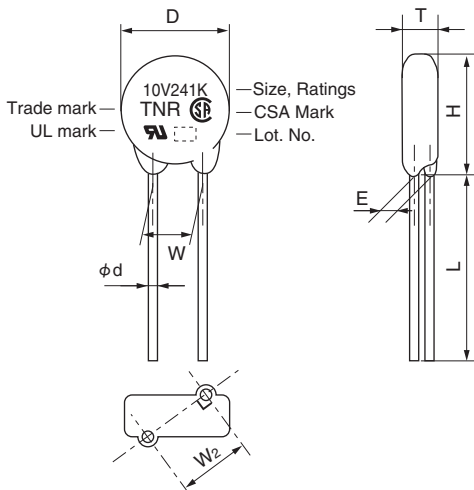

Part Number	D Max.	H Max.	T Max.	L Min.	φd ±0.05	W ±1.0
TND10V-150K to TND10V-511K	11.5	14.5	Ref. to RATINGS	20.0	0.8	7.5
TND10V-561K to TND10V-112K	12.5	15.5				
TND10V-122K to TND10V-182K	13.5	16.5				

V Series

◆V-I CURVE (Type 10V)

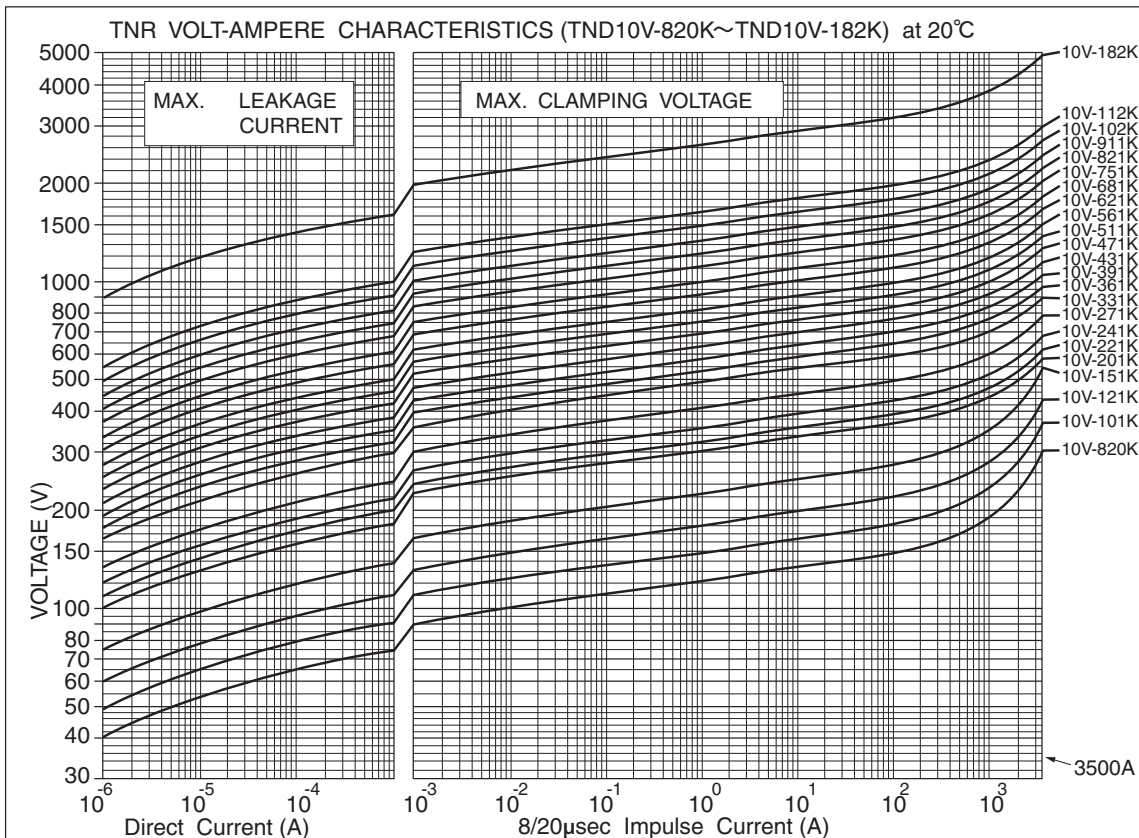
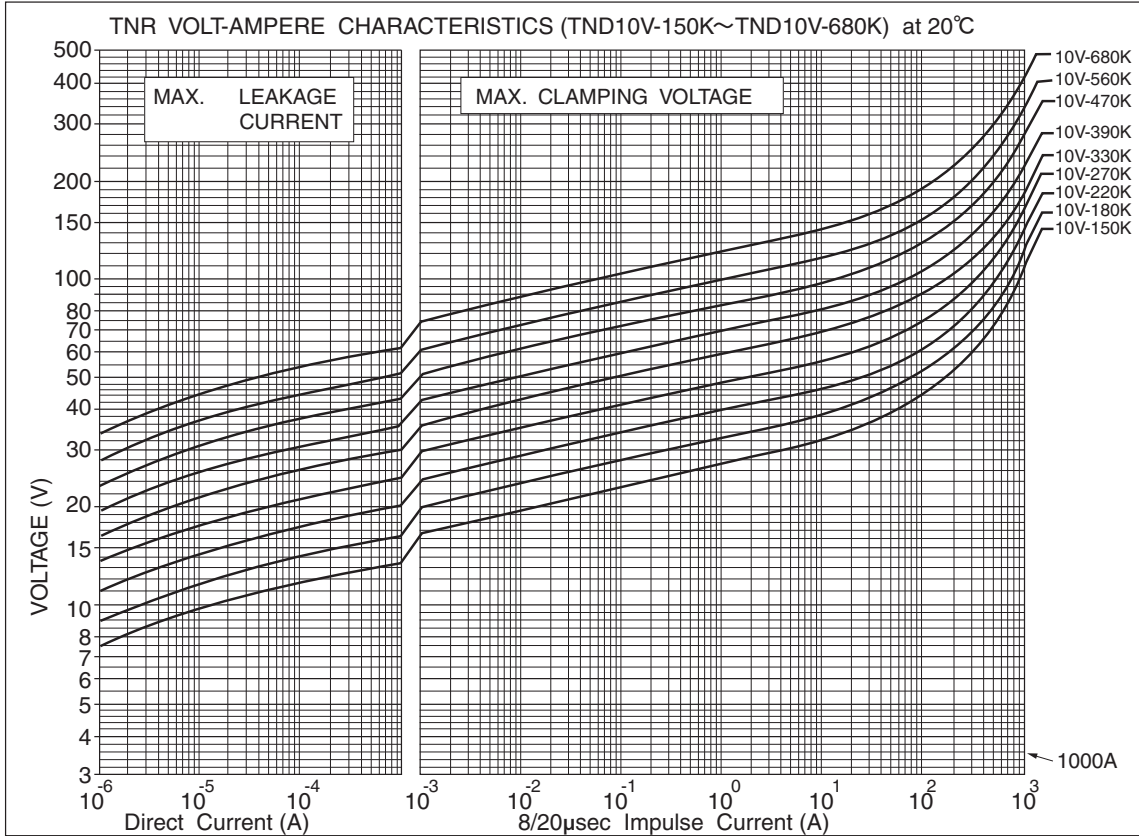

V Series

◆ RATINGS (Type 12V)

Part Number	Previous Part Number (Just for your reference)	Maximum Ratings					Max. Clamping Voltage		Capacitance Typical @1kHz	Varistor Voltage V1mA	T Max.	E ±1.0	W2 reference
		Max. Allowable Voltage		Max. Peak Current	Max. Energy	Rated Wattage	(A)	(V)					
		AC (Vrms)	DC (V)	8/20μs(A)	2ms(J)	(W)			(pF)	(V)	(mm)	(mm)	(mm)
TND12V-431KB00AAA0	TNR12V431K	275	350		55			710	375	430 (387 ~ 473)	6.0	2.0	7.8
TND12V-471KB00AAA0	TNR12V471K	300	385		60			775	345	470 (423 ~ 517)	6.2	2.1	7.8
TND12V-511KB00AAA0	TNR12V511K	320	410		67			845	330	510 (459 ~ 561)	6.4	2.3	7.8
TND12V-561KB00AAA0	TNR12V561K	350	460		67			922	305	560 (504 ~ 616)	6.7	2.5	7.9
TND12V-621KB00AAA0	TNR12V621K	385	505		67			1025	280	620 (558 ~ 682)	7.1	2.7	8.0
TND12V-681KB00AAA0	TNR12V681K	420	560	4,200A/1 time	67			1120	260	680 (612 ~ 748)	7.4	2.9	8.0
TND12V-751KB00AAA0	TNR12V751K	460	615		70	0.4	25	1240	235	750 (675 ~ 825)	7.8	3.1	8.1
TND12V-821KB00AAA0	TNR12V821K	510	670	3,000A/2 times	80			1355	220	820 (738 ~ 902)	8.1	3.4	8.2
TND12V-911KB00AAA0	TNR12V911K	550	745		90			1500	195	910 (819 ~ 1001)	8.6	3.7	8.4
TND12V-102KB00AAA0	TNR12V102K	625	825		100			1650	180	1000 (900 ~ 1100)	9.1	4.0	8.5
TND12V-112KB00AAA0	TNR12V112K	680	895		110			1815	165	1100 (990 ~ 1210)	9.7	4.4	8.7
TND12V-122KB00AAA0	TNR12V122K	720	980		120			1950	150	1200 (1080 ~ 1320)	10.5	4.7*	8.9**
TND12V-152KB00AAA0	TNR12V152K	860	1220		150			2440	135	1500 (1350 ~ 1650)	12.4	5.8*	9.5**
TND12V-182KB00AAA0	TNR12V182K	1000	1465		183			2970	110	1800 (1700 ~ 1980)	14.4	6.9*	10.2**

*E±2 **W2±2

◆ DIMENSIONS [mm]

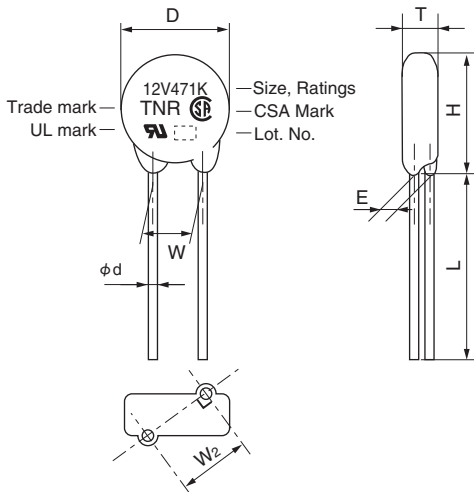

Part Number	D Max.	H Max.	T Max.	L Min.	φd ±0.05	W ±1.0
TND12V-431K to TND12V-102K	14.0	17.0	Ref. to RATINGS	20	0.8	7.5
TND12V-112K	15.0	18.0				
TND12V-122K	16.0	19.0				
TND12V-152K to TND12V-182K	16.0	19.0				



V Series

◆V-I CURVE (Type 12V)

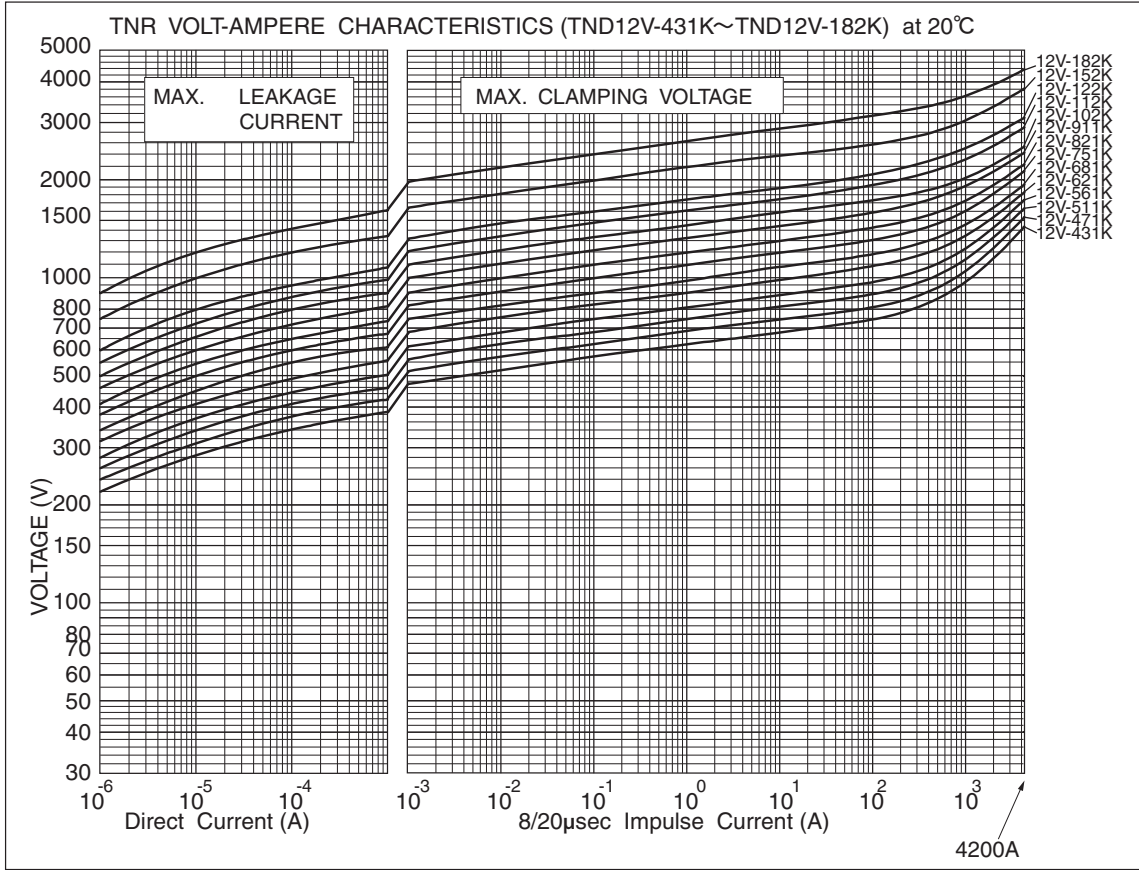

◆RATINGS (Type 14V)

Part Number	Previous Part Number (Just for your reference)	Maximum Ratings					Max. Clamping Voltage	Capacitance Typical @1kHz	Varistor Voltage V1mA	T Max.	E ±1.0	W2 Reference
		Max. Allowable Voltage		Max. Peak Current	Max. Energy	Rated Wattage						
		AC (Vrms)	DC (V)	8/20µs(A)	2ms(J)	(W)						
TND14V-150KB00AAA0	TNR14V150K	8	12		3.6		30	19500	15 (13~ 17)	4.5	1.0	7.6
TND14V-180KB00AAA0	TNR14V180K	11	14		4.3		36	16500	18 (16~ 20)	4.6	1.1	7.6
TND14V-220KB00AAA0	TNR14V220K	14	18		5.3		43	13500	22 (20~ 24)	4.7	1.2	7.6
TND14V-270KB00AAA0	TNR14V270K	17	22	2000A/1 time	6.5		53	12000	27 (24~ 30)	4.8	1.4	7.6
TND14V-330KB00AAA0	TNR14V330K	20	26		7.9	0.1	65	10000	33 (30~ 36)	5.0	1.6	7.7
TND14V-390KB00AAA0	TNR14V390K	25	30	1000A/2 times	9.4		77	9000	39 (35~ 43)	4.9	1.3	7.6
TND14V-470KB00AAA0	TNR14V470K	30	37		11		93	8000	47 (42~ 52)	5.0	1.5	7.6
TND14V-560KB00AAA0	TNR14V560K	35	44		13		110	7500	56 (50~ 62)	5.1	1.7	7.7
TND14V-680KB00AAA0	TNR14V680K	40	55		16		135	6500	68 (61~ 75)	5.3	2.0	7.8
TND14V-820KB00AAA0	TNR14V820K	50	65		20		135	3000	82 (74~ 90)	4.5	1.1	7.6
TND14V-101KB00AAA0	TNR14V101K	60	85		25		165	2700	100 (90~ 110)	4.7	1.3	7.6
TND14V-121KB00AAA0	TNR14V121K	75	100		30		200	2500	120 (108~ 132)	4.9	1.4	7.6
TND14V-151KB00AAA0	TNR14V151K	95	125		37		250	2300	150 (135~ 165)	5.2	1.7	7.7
TND14V-181KB00AAA0	TNR14V181K	110	145		45		300	1650	180 (162~ 198)	4.7	1.1	7.6
TND14V-201KB00AAA0	TNR14V201K	130	170		50		340	950	200 (185~ 225)	4.8	1.2	7.6
TND14V-221KB00AAA0	TNR14V221K	140	180	6000A/1 time	55		360	850	220 (198~ 242)	4.9	1.3	7.6
TND14V-241KB00AAA0	TNR14V241K	150	200		60		395	800	240 (216~ 264)	5.0	1.4	7.6
TND14V-271KB00AAA0	TNR14V271K	175	225	5000A/2 times	70		455	700	270 (247~ 303)	5.2	1.5	7.6
TND14V-331KB00AAA0	TNR14V331K	210	270		80		545	600	330 (297~ 363)	5.5	1.7	7.7
TND14V-361KB00AAA0	TNR14V361K	230	300		90		595	550	360 (324~ 396)	5.7	1.8	7.7
TND14V-391KB00AAA0	TNR14V391K	250	320		100		650	500	390 (351~ 429)	5.8	1.9	7.7
TND14V-431KB00AAA0	TNR14V431K	275	350		110	0.6	710	460	430 (387~ 473)	6.0	2.1	7.8
TND14V-471KB00AAA0	TNR14V471K	300	385		125		775	420	470 (423~ 517)	6.2	2.2	7.8
TND14V-511KB00AAA0	TNR14V511K	320	410		136		845	390	510 (459~ 561)	6.4	2.4	7.9
TND14V-561KB00AAA0	TNR14V561K	350	460		136		922	360	560 (504~ 616)	6.7	2.6	7.9
TND14V-621KB00AAA0	TNR14V621K	385	505		136		1025	330	620 (558~ 682)	7.1	2.8	8.0
TND14V-681KB00AAA0	TNR14V681K	420	560		136		1120	310	680 (612~ 748)	7.4	3.0	8.1
TND14V-751KB00AAA0	TNR14V751K	460	615		150		1240	280	750 (675~ 825)	7.8	3.3	8.2
TND14V-821KB00AAA0	TNR14V821K	510	670	5000A/1 time	165		1355	250	820 (738~ 902)	8.1	3.5	8.3
TND14V-911KB00AAA0	TNR14V911K	550	745		180		1500	230	910 (819~1001)	8.6	3.9	8.5
TND14V-102KB00AAA0	TNR14V102K	625	825	4500A/2 times	200		1650	210	1000 (900~1100)	9.1	4.2	8.6
TND14V-112KB00AAA0	TNR14V112K	680	895		220		1815	190	1100 (990~1210)	9.7	4.6	8.8
TND14V-122KB00AAA0	TNR14V122K	720	980		240		1950	170	1200 (1080~1320)	10.5	4.9*	9.0**
TND14V-152KB00AAA0	TNR14V152K	860	1220		300		2440	150	1500 (1350~1650)	12.4	6.0*	9.6**
TND14V-182KB00AAA0	TNR14V182K	1000	1465		360		2970	120	1800 (1700~1980)	14.4	7.1*	10.3**

*E±2 **W2±2

◆DIMENSIONS [mm]

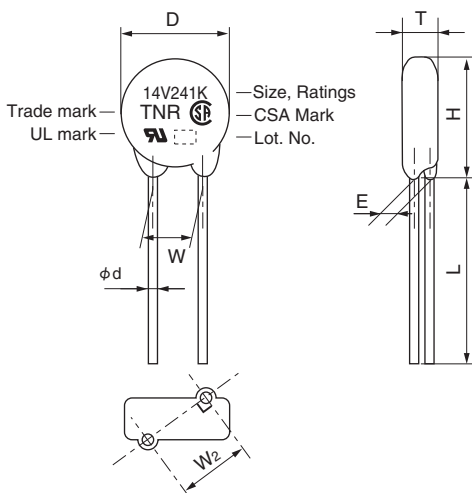

Part Number	D Max.	H Max.	T Max.	L Min.	φd ±0.05	W ±1.0
TND14V-150K to TND14V-511K	15.5	18.5	Ref. to RATINGS	20	0.8	7.5
TND14V-561K to TND14V-112K	16.0	19.0				
TND14V-122K to TND14V-182K	17.0	20.5				

V Series

◆V-I CURVE (Type 14V)

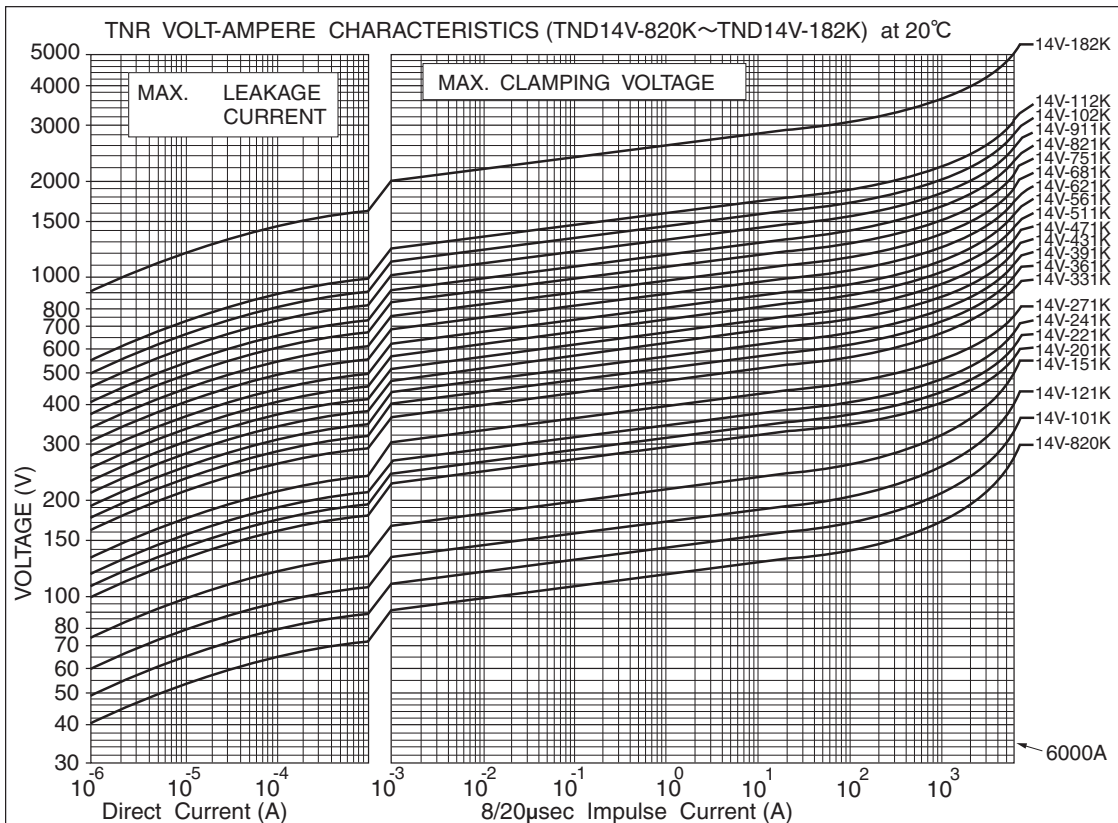
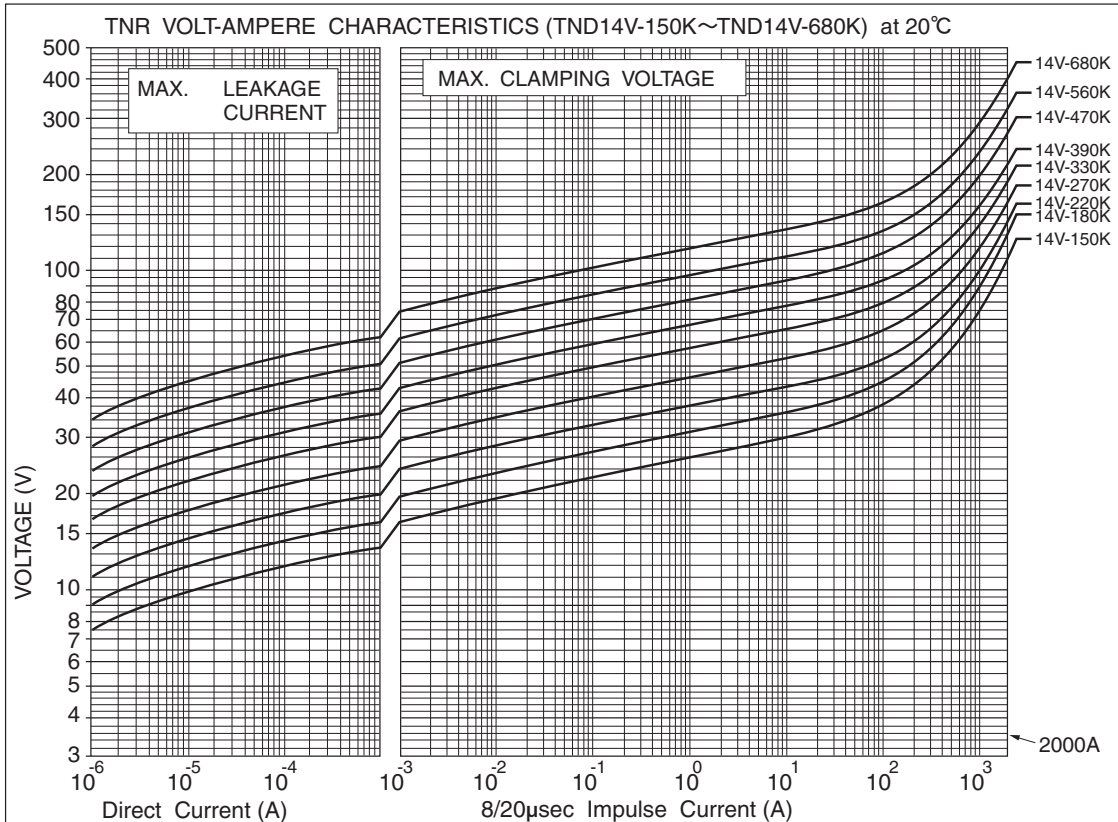

◆ RATINGS (Type 20V)

Part Number	Previous Part Number (Just for your reference)	Maximum Ratings					Max. Clamping Voltage		Capacitance Typical @1kHz	Varistor Voltage V _{1mA}	T Max.	E ±1.0	W ₂ Reference
		Max. Allowable Voltage		Max. Peak Current	Max. Energy	Rated Wattage	(A)	(V)					
		AC (Vrms)	DC (V)	8/20μs(A)	2ms(J)	(W)			(pF)	(V)	(mm)	(mm)	(mm)
TND20V-180KB00AAA0	TNR20V180K	11	14	3000A/1 time	12	0.2	20	36	39000	18 (16~ 20)	5.1	1.1	10.1
TND20V-220KB00AAA0	TNR20V220K	14	18		14			43	33000	22 (20~ 24)	5.2	1.2	10.1
TND20V-270KB00AAA0	TNR20V270K	17	22		17			53	28000	27 (24~ 30)	5.3	1.4	10.1
TND20V-330KB00AAA0	TNR20V330K	20	26	2000A/2 times	21	1.0	100	65	24000	33 (30~ 36)	5.5	1.6	10.1
TND20V-390KB00AAA0	TNR20V390K	25	30		25			77	21000	39 (35~ 43)	5.5	1.3	10.1
TND20V-470KB00AAA0	TNR20V470K	30	37		30			93	19000	47 (42~ 52)	5.6	1.5	10.1
TND20V-560KB00AAA0	TNR20V560K	35	44	10000A/1 time	36	1.0	100	110	17000	56 (50~ 62)	5.7	1.7	10.1
TND20V-680KB00AAA0	TNR20V680K	40	55		44			135	15000	68 (61~ 75)	5.8	2.0	10.2
TND20V-820KB00AAA0	TNR20V820K	50	65		40			135	6700	82 (74~ 90)	4.9	1.2	10.1
TND20V-101KB00AAA0	TNR20V101K	60	85	50	165	6100	100 (90~ 110)	5.1	1.4	10.1			
TND20V-121KB00AAA0	TNR20V121K	75	100	60	200	5600	120 (108~ 132)	5.3	1.5	10.1			
TND20V-151KB00AAA0	TNR20V151K	95	125	75	250	5100	150 (135~ 165)	5.6	1.8	10.2			
TND20V-181KB00AAA0	TNR20V181K	110	145	85	300	3900	180 (162~ 198)	5.1	1.2	10.1			
TND20V-201KB00AAA0	TNR20V201K	130	170	100	340	2700	200 (185~ 225)	5.2	1.2	10.1			
TND20V-221KB00AAA0	TNR20V221K	140	180	7000A/2 times	110	1.0	100	360	2500	220 (198~ 242)	5.3	1.3	10.1
TND20V-241KB00AAA0	TNR20V241K	150	200		120			395	2300	240 (216~ 264)	5.4	1.4	10.1
TND20V-271KB00AAA0	TNR20V271K	175	225		135			455	2000	270 (247~ 303)	5.6	1.5	10.1
TND20V-331KB00AAA0	TNR20V331K	210	270	160	545	1700	330 (297~ 363)	5.9	1.7	10.1			
TND20V-361KB00AAA0	TNR20V361K	230	300	180	595	1500	360 (324~ 396)	6.1	1.9	10.2			
TND20V-391KB00AAA0	TNR20V391K	250	320	195	650	1400	390 (351~ 429)	6.2	2.0	10.2			
TND20V-431KB00AAA0	TNR20V431K	275	350	215	710	1300	430 (387~ 473)	6.4	2.1	10.2			
TND20V-471KB00AAA0	TNR20V471K	300	385	250	775	1200	470 (423~ 517)	6.6	2.3	10.3			
TND20V-511KB00AAA0	TNR20V511K	320	410	273	845	1100	510 (459~ 561)	6.8	2.4	10.3			
TND20V-561KB00AAA0	TNR20V561K	350	460	7500A/1 time	273	1.0	100	922	1000	560 (504~ 616)	7.1	2.6	10.3
TND20V-621KB00AAA0	TNR20V621K	385	505		273			1025	900	620 (558~ 682)	7.5	2.9	10.4
TND20V-681KB00AAA0	TNR20V681K	420	560		273			1120	830	680 (612~ 748)	7.8	3.1	10.5
TND20V-751KB00AAA0	TNR20V751K	460	615	300	1240	750	750 (675~ 825)	8.2	3.4	10.6			
TND20V-821KB00AAA0	TNR20V821K	510	670	325	1355	700	820 (738~ 902)	8.5	3.6	10.6			
TND20V-911KB00AAA0	TNR20V911K	550	745	360	1500	620	910 (819~ 1001)	9.0	4.0	10.8			
TND20V-102KB00AAA0	TNR20V102K	625	825	6500A/2 times	400	1.0	100	1650	560	1000 (900~ 1100)	9.5	4.3	10.9
TND20V-112KB00AAA0	TNR20V112K	680	895		440			1815	510	1100 (990~ 1210)	10.1	4.7	11.0
TND20V-122KB00AAA0	TNR20V122K	720	980		480			1950	450	1200 (1080~ 1320)	10.8	5.1*	11.2**
TND20V-152KB00AAA0	TNR20V152K	860	1220	600	2440	390	1500 (1350~ 1650)	12.8	6.2*	11.8**			
TND20V-182KB00AAA0	TNR20V182K	1000	1465	720	2970	340	1800 (1700~ 1980)	14.8	7.4*	12.4**			

*E±2 **W2±2

◆ DIMENSIONS [mm]

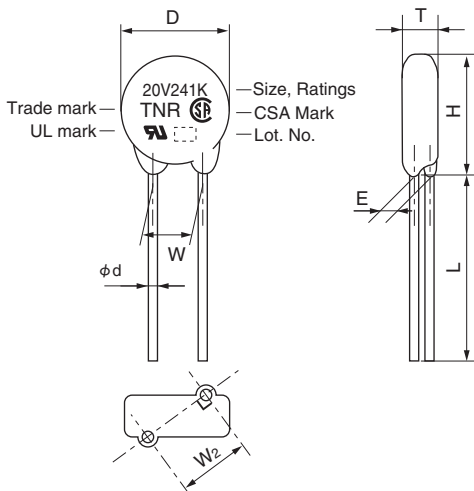

Part Number	D Max.	H Max.	T Max.	L Min.	φd ±0.05	W ±1.0
TND20V-180K to TND20V-511K	21.5	24.5	Ref. to Ratings	20	0.8	10.0
TND20V-561K to TND20V-112K	22.5	25.5				
TND20V-122K to TND20V-182K	23.5	28.0				

V Series

◆V-I CURVE (Type 20V)

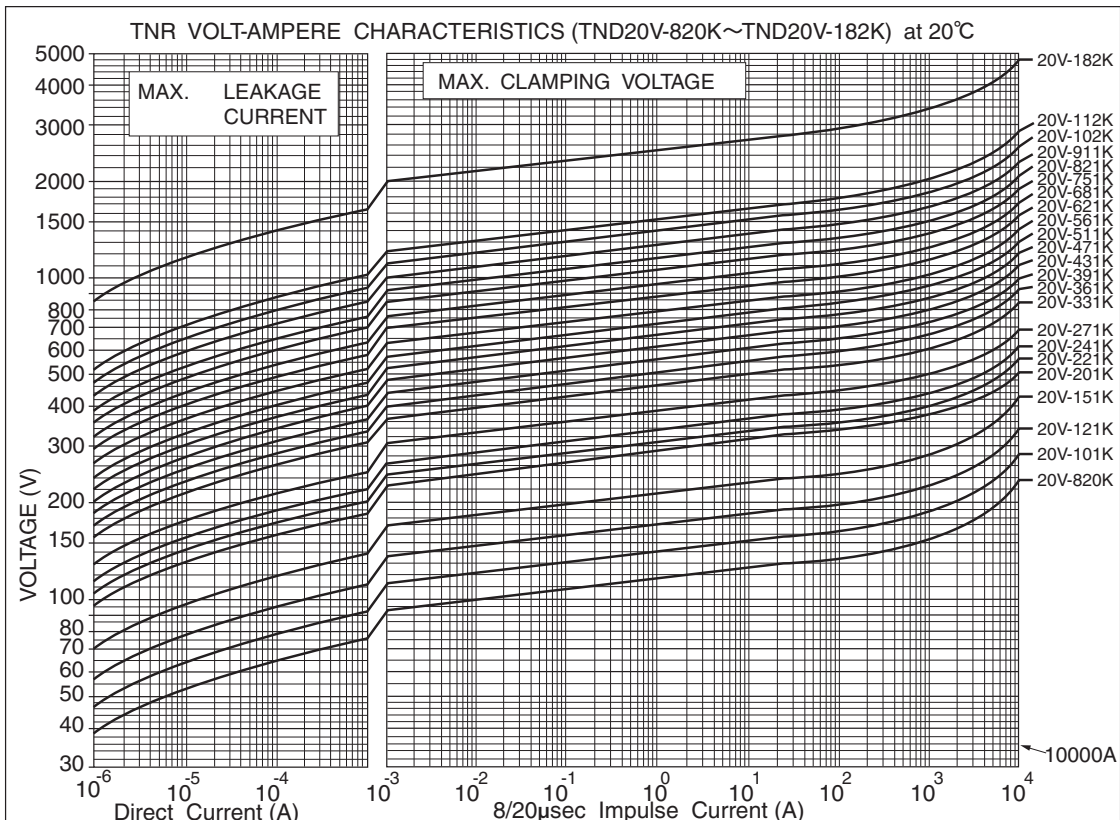
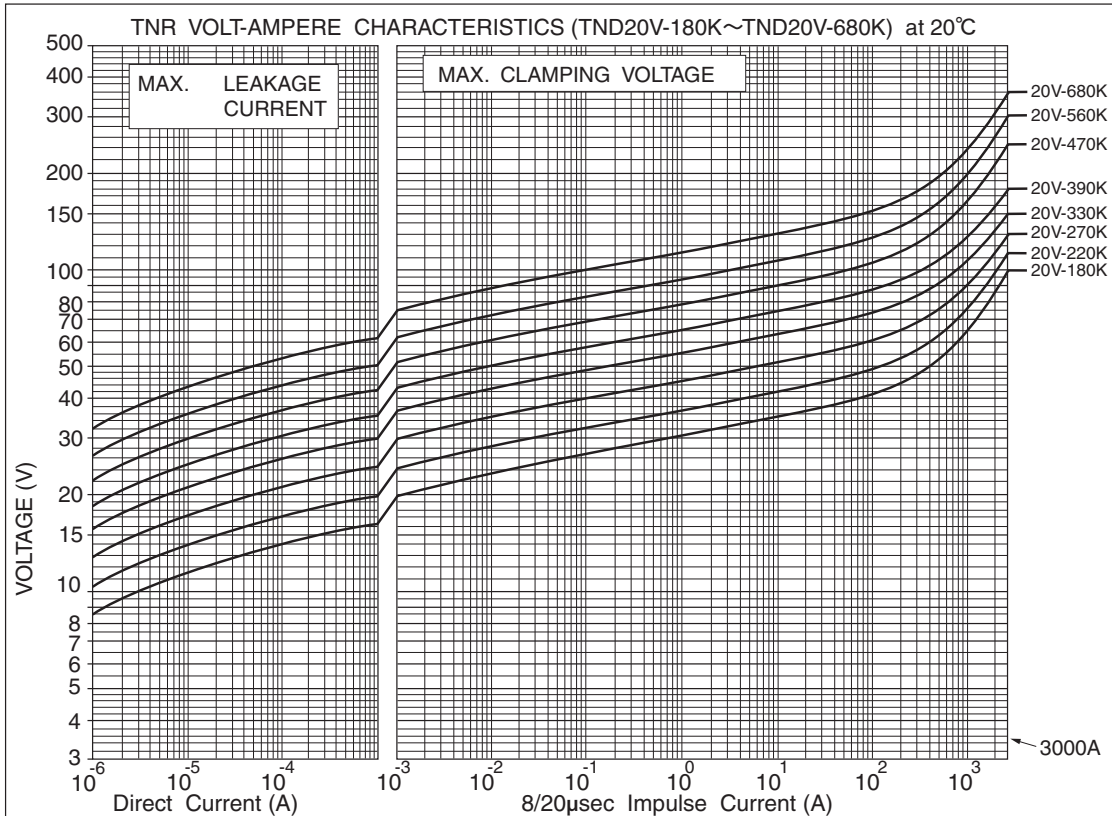



V Series

◆GENERAL SPECIFICATIONS

Item	Test Conditions	Specifications						
Standard Test Condition	20±5°C, 65±20%RH unless specified. However, if it does not affect test result, the condition can be 20±15°C, 65±20%RH also.							
Varistor Voltage	Voltage across varistor at specified current. <table border="1" style="margin-left: 20px;"> <thead> <tr> <th>Type</th> <th>Current CmA</th> </tr> </thead> <tbody> <tr> <td>5V</td> <td>0.1</td> </tr> <tr> <td>7V, 9V, 10V, 12V, 14V, 20V</td> <td>1.0</td> </tr> </tbody> </table>	Type	Current CmA	5V	0.1	7V, 9V, 10V, 12V, 14V, 20V	1.0	Satisfy the specification
Type	Current CmA							
5V	0.1							
7V, 9V, 10V, 12V, 14V, 20V	1.0							
Maximum Allowable Voltage	Maximum continuous AC voltage (50 to 60Hz AC) and maximum DC voltage which can be applied.	Satisfy the specification						
Maximum Peak Surge Current	Maximum surge current (8/20µs pulse wave to be applied once, or twice, 2 minutes apart) for varistor voltage change within ±10% of the initial value.	Satisfy the specification						
Energy Rating	Maximum energy (2 ms. square wave to be applied once) for varistor voltage change within ±10% of the initial value.	Satisfy the specification						
Rated Wattage	Maximum power (50 to 60Hz AC power to be applied for 1000 hours at 85±2°C) for varistor voltage change within ±10% of the initial value.	Satisfy the specification						
Maximum Clamping Voltage	Maximum voltage across varistor when 8/20µs rated current surge is applied.	Satisfy the specification						
Capacitance	Varistor's capacitance at 1kHz, standard test condition.	For reference only.						
Voltage Temperature Coefficient	$\frac{V_{cmA} \text{ at } 85^{\circ}\text{C} - V_{cmA} \text{ at } 25^{\circ}\text{C}}{V_{cmA} \text{ at } 25^{\circ}\text{C}} \times \frac{1}{60} \times 100 (\%/^{\circ}\text{C})$ VcmA : Actual varistor voltage	Within ±0.05%/°C						
Insulation	Short circuit the two leads of varistor, and put the varistor body into metal balls (1.6mm diameter) leaving 2mm epoxy coating outside. Then, apply 2.5kVrms between the leads and the metal balls for 60±5 sec..	The varistor shall withstand with no abnormality.						

◆ENVIRONMENTAL CHARACTERISTICS

Item	Test Conditions	Specifications
High Temperature Storage (Dry heat)	The specimen shall be subjected 125±2°C for 1000±12 hours without load.	ΔVcmA ≤±5% However, on varistors have nominal varistor voltages from 15V to 68V, the varistor voltage change shall be ΔVcmA ≤±10%
Low Temperature Storage	The specimen shall be subjected -40±2°C for 1000±12 hours without load.	ΔVcmA ≤±5%
Damp heat (Humidity)	The specimen shall be subjected to 40±2°C, 90 to 95%RH for 1000±12 hours without load.	ΔVcmA ≤±5%
Temperature Cycle	The temperature cycle shown below shall be repeated 5 cycles. -40±3°C, 30 minutes ⇄ +85±2°C, 30 minutes	ΔVcmA ≤±5% No remarkable damage
High Temperature Operating	The specimen shall be subjected to 85±2°C with the maximum allowable voltage for 1000±12 hours.	ΔVcmA ≤±10%
Damp heat Operating	The specimen shall be subjected to 40±2°C, 90 to 95%RH with the maximum allowable voltage for 1000±12 hours.	ΔVcmA ≤±10%

Varistor voltage change of forward direction shall be measured in the test of unipolar surge life and DC load life.

Varistor voltage change is measured after stored at Standard Test Conditions for 1 to 2 hours.

Note : For 42V battery line, please contact our sales office.



◆MECHANICAL CHARACTERISTICS

Item	Test Conditions	Specifications												
Resistance to Soldering Heat	Each lead shall be dipped into a solder bath having a temperature of 350±10°C to a point 2.0 to 2.5 mm from the body of the unit, be held there for 3 ⁺¹ ₀ sec and then be stored at room temperature for 1 to 2 hours. The ΔVcmA and mechanical damage shall be examined. or Each lead shall be dipped into a solder bath having a temperature of 260±10°C to a point 2.0 to 2.5 mm from the body of the unit, be held there for 10±1 sec and then be stored at room temperature for 1 to 2 hours. The ΔVcmA and mechanical damage shall be examined.	ΔVcmA ≤±5% No remarkable damage												
Solderability	Each lead shall be dipped into a methanol solution (about 25%) of rosin for 5 to 10 sec. Then each lead shall be dipped into a solder.	At least, 95% of the leads shall be covered with solder uniformly.												
	<table border="1"> <tr> <td>Solder</td> <td>Pb free (Sn-3.0Ag-0.5Cu)</td> <td>Eutectic (Sn/Pb)</td> </tr> <tr> <td>Solder Temp.</td> <td>245±5°C</td> <td>235±5°C</td> </tr> <tr> <td>Dipping Time</td> <td colspan="2">2±0.5sec.</td> </tr> <tr> <td>Dipping Depth</td> <td colspan="2">1.5 to 2.0mm (from the body)</td> </tr> </table>		Solder	Pb free (Sn-3.0Ag-0.5Cu)	Eutectic (Sn/Pb)	Solder Temp.	245±5°C	235±5°C	Dipping Time	2±0.5sec.		Dipping Depth	1.5 to 2.0mm (from the body)	
	Solder		Pb free (Sn-3.0Ag-0.5Cu)	Eutectic (Sn/Pb)										
	Solder Temp.		245±5°C	235±5°C										
Dipping Time	2±0.5sec.													
Dipping Depth	1.5 to 2.0mm (from the body)													
Lead Pull Strength	Fix varistor body, and suspend specified weight toward direction of lead axis.	No abnormality such as disconnection. ΔVcmA ≤±5%												
	<table border="1"> <tr> <td>Type</td> <td>Lead Diameter</td> <td>Weight</td> </tr> <tr> <td>5V, 7V, 9V</td> <td>0.6mm</td> <td>10N</td> </tr> <tr> <td>10V, 12V, 14V, 20V</td> <td>0.8mm</td> <td>10N</td> </tr> </table>		Type	Lead Diameter	Weight	5V, 7V, 9V	0.6mm	10N	10V, 12V, 14V, 20V	0.8mm	10N			
	Type		Lead Diameter	Weight										
5V, 7V, 9V	0.6mm	10N												
10V, 12V, 14V, 20V	0.8mm	10N												
Lead Bend Strength	Fix varistor body vertically. Then suspend specified weight and bent the varistor body by 90°, and return it to the original position. Carry out the operation in the opposite direction and return the body to the original position.	The leads shall not disconnect, slacken and peel off.												
	<table border="1"> <tr> <td>Type</td> <td>Lead Diameter</td> <td>Weight</td> </tr> <tr> <td>5V, 7V, 9V</td> <td>0.6mm</td> <td>5N</td> </tr> <tr> <td>10V, 12V, 14V, 20V</td> <td>0.8mm</td> <td>5N</td> </tr> </table>		Type	Lead Diameter	Weight	5V, 7V, 9V	0.6mm	5N	10V, 12V, 14V, 20V	0.8mm	5N			
	Type		Lead Diameter	Weight										
5V, 7V, 9V	0.6mm	5N												
10V, 12V, 14V, 20V	0.8mm	5N												
Vibration	Mount varistor body on vibrator, and conduct the following vibration test. Peak-to-Peak amplitude : 1.5mm Vibration frequency range : 10Hz to 55Hz Sweeping time: Approximately one minute for 10Hz → 55Hz → 10Hz Direction and duration of vibration : Three directions of X, Y and Z. Two hours each. Six hours total.	No remarkable appearance abnormality. ΔVcmA ≤±5%												



SE Series

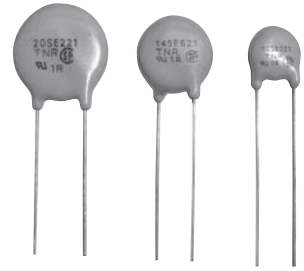

When the surge energy much higher than the rated maximum energy is applied to the varistors, it may blow up and catch fire.
 TNR SE series is to prevent from being caught fire even very high surge energy is applied.
 Thus electric appliance using our TNR SE series can be much safer.

◆FEATURES

- Newly developed non-flammable material (Halogen Free) is used for outer coating.
- The new outer coating will meet UL flammability test.
- At the over voltage test, the new material shall deter burning caused by the high temperature, arc and the large surge current when TNR shall blow up.
- General specifications are same as that of V series, large surge capability TNR.
- Strong to thermal shock. (-40°C - 85°C, 50 cycles)
- UL, CSA and VDE recognized components
 - UL1449 3rd File : E323623
 - UL1414 File : E65426 (Except "12SE")
 - CSA File : LR97864
 - VDE File : 118623

◆APPLICATIONS

- Protection for semiconductors from over voltage.
- Protection for electronic instruments from lightning surge.
- Absorption of on-off surge from motors and relays.

Operating Temperature Range: -40 to +85°C
 Storage Temperature Range: -50 to +125°C

◆PART NUMBERING SYSTEM

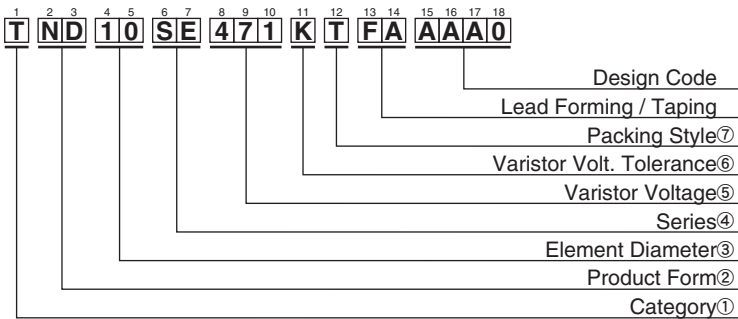

①Category	
T	Metal Oxide Varistors TNR

②Product Form	
ND	Disk Type

③Element Diameter	
10	φ10 mm
12	φ12 mm
14	φ14 mm
20	φ20 mm

④Series	
SE	SE Series

⑤Varistor Voltage	
The first two digits are significant figures and the third one denotes the number of following zeros.	

⑥Varistor Volt. Tolerance	
K	±10%

⑦Packing Style	
B	Bulk
T	Taping

SE Series

◆ RATINGS AND CHARACTERISTICS

Part Number	Previous Part Number (Just for your reference)	Maximum Ratings					Max. Clamping Voltage		Capacitance Typical @1kHz	Varistor Voltage V _{1mA}	Thickness T MAX.
		Max. Allowable Voltage		Max. Peak Current	Max. Energy	Rated Wattage	(A)	(V)			
		AC (Vrms)	DC (V)	8/20μs(A)	2ms(J)	(W)			(pF)	(V)	
TND10SE221KT**AAA0	TNR10SE221K-T**	140	180	3500A/1 time	27.5	0.4	25	360	450	220 (198~242)	6.9
TND10SE241KT**AAA0	TNR10SE241K-T**	150	200		30			395	400	240 (216~264)	
TND10SE271KT**AAA0	TNR10SE271K-T**	175	225		35			455	350	270 (247~303)	
TND10SE431KT**AAA0	TNR10SE431K-T**	275	350	2500A/2 times	55	0.4	25	710	240	430 (387~473)	8.2
TND10SE471KT**AAA0	TNR10SE471K-T**	300	385		60			775	220	470 (423~517)	
TND10SE511KT**AAA0	TNR10SE511K-T**	320	410		67			845	210	510 (459~561)	
TND10SE621KT**AAA0	TNR10SE621K-T**	385	505	67	1025	180	620 (558~682)	11.5			
TND12SE431KT**AAA0	TNR12SE431K-T**	275	350	4200A/1 time	55	0.4	25	710	460	430 (387~473)	8.2
TND12SE471KT**AAA0	TNR12SE471K-T**	300	385		60			775	420	470 (423~517)	
TND12SE511KT**AAA0	TNR12SE511K-T**	320	410		67			845	390	510 (459~561)	
TND12SE621KT**AAA0	TNR12SE621K-T**	385	505	67	1025	330	620 (558~682)	11.5			
TND14SE221KT**AAA0	TNR14SE221K-T**	140	180	6000A/1 time	55	0.6	50	360	850	220 (198~242)	6.9
TND14SE241KT**AAA0	TNR14SE241K-T**	150	200		60			395	800	240 (216~264)	
TND14SE271KT**AAA0	TNR14SE271K-T**	175	225		70			455	700	270 (247~303)	
TND14SE431KT**AAA0	TNR14SE431K-T**	275	350	5000A/2 times	110	0.6	50	710	460	430 (387~473)	8.2
TND14SE471KT**AAA0	TNR14SE471K-T**	300	385		125			775	420	470 (423~517)	
TND14SE511KT**AAA0	TNR14SE511K-T**	320	410		136			845	390	510 (459~561)	
TND14SE621KT**AAA0	TNR14SE621K-T**	385	505	5000A/1 time 4500A/2 times	136			1025	330	620 (558~682)	11.5
TND20SE221KB00AAA0	TNR20SE221K	140	180	10000A/1 time	110	1.0	100	360	2500	220 (198~242)	6.9
TND20SE241KB00AAA0	TNR20SE241K	150	200		120			395	2300	240 (216~264)	
TND20SE271KB00AAA0	TNR20SE271K	175	225		135			455	2000	270 (247~303)	
TND20SE431KB00AAA0	TNR20SE431K	275	350	7000A/2 times	215	1.0	100	710	1300	430 (387~473)	8.2
TND20SE471KB00AAA0	TNR20SE471K	300	385		250			775	1200	470 (423~517)	
TND20SE511KB00AAA0	TNR20SE511K	320	410		273			845	1100	510 (459~561)	
TND20SE621KB00AAA0	TNR20SE621K	385	505	7500A/1 time 6500A/2 times	273			1025	900	620 (558~682)	11.5

** : Taping Code

◆ DIMENSIONS [mm]

TND10SE/TND12SE/TND14SE: Taping product is the standard specifications.

Taping Code (Previous)	Lead Shape	Hole Pitch (mm)
TFA (-T15)	Crimped, Parallel	12.7
TFB (-T8)	Crimped, Parallel	15.0

Taping Code: TFA

Symbol	10SE	~12SE511K	12SE621K	14SE
D	14.0 MAX.	15.0 MAX.	16.0 MAX.	17.5 MAX.
φd	0.8±0.05	←	←	←
P	25.4±1.0	←	←	←
P0	12.7±0.3	←	←	←
φD0	4.0±0.2	←	←	←
P1	2.6±0.5	←	←	←
W1	9.0±0.5	←	←	←
F0	7.5±0.8	←	←	←
Δh	0±2.0	←	←	←
ΔP	0±1.0	←	←	←
W	18.0±0.5	←	←	←
W0	5.0 MIN.	←	←	←
W2	3.0 MAX.	←	←	←
t	0.6±0.3	←	←	←
H0	16.0±1.0	←	←	←
H	21.0 MAX.	23.0 MAX.	24.0 MAX.	25.0 MAX.
H1	38.0 MAX.	41.0 MAX.	←	42.0 MAX.
J	6.0 MAX.	←	←	←

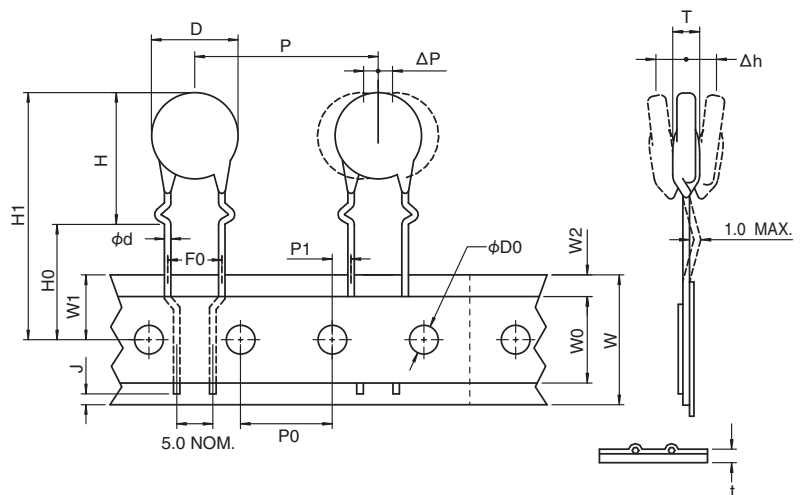

SE Series

Taping Code: TFB

Symbol	10SE	~12SE511K	12SE621K	14SE
D	14.0 MAX.	15.0 MAX.	16.0 MAX.	17.5 MAX.
φd	0.8±0.05	←	←	←
P	15.0±1.0	←	←	30.0±1.0
P0	15.0±0.3	←	←	←
φD0	4.0±0.2	←	←	←
P1	3.75±0.5	←	←	←
W1	9.0±0.5	←	←	←
F0	7.5±0.8	←	←	←
Δh	0±2.0	←	←	←
ΔP	0±1.0	←	←	←
W	18.0±0.5	←	←	←
W0	5.0 MIN.	←	←	←
W2	3.0 MAX.	←	←	←
t	0.6±0.3	←	←	←
H0	16.0±1.0	←	←	←
H	21.0 MAX.	23.0 MAX.	24.0 MAX.	25.0 MAX.
H1	38.0 MAX.	41.0 MAX.	42.0 MAX.	42.0 MAX.
J	6.0 MAX.	←	←	←

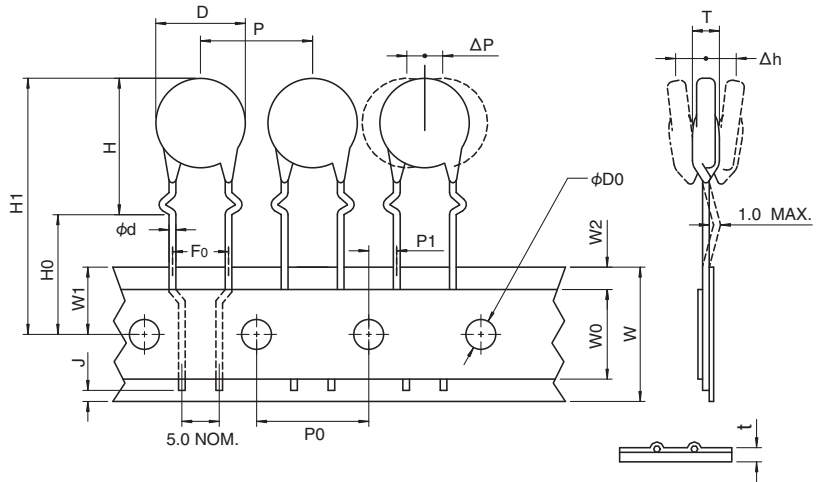

TND20SE: Bulk only

Part Number	D Max.	H Max.	L Min.	φd ±0.05	W ±1.0	E ±1.0
TND20SE221KB00AAA0	22.5	27.5	20	0.8	10	1.3
TND20SE241KB00AAA0						1.4
TND20SE271KB00AAA0						1.5
TND20SE431KB00AAA0						2.1
TND20SE471KB00AAA0						2.3
TND20SE511KB00AAA0						2.4
TND20SE621KB00AAA0	24.5	29.5				2.9

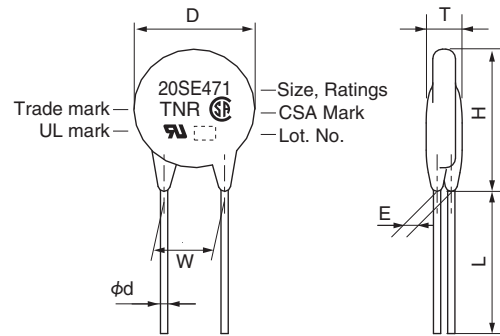

◆ V-I CURVE and PULSE LIFE TIME RATINGS

V-I characteristics and PULSE LIFE TIME RATINGS are same as those of V series.

Please see V-I CURVE and PULSE LIFE TIME RATINGS of V series.

CROSS REFERENCE TABLE

TNR SE SERIES	TNR V SERIES	V-I CURVE GO TO REF. PAGE	PULSE LIFE TIME RATINGS GO TO REF. PAGE
TND10SE221K TND10SE241K TND10SE271K TND10SE431K TND10SE471K TND10SE511K TND10SE621K	TND10V-221K TND10V-241K TND10V-271K TND10V-431K TND10V-471K TND10V-511K TND10V-621K	GO	GO
TND12SE431K TND12SE471K TND12SE511K TND12SE621K	TND12V-431K TND12V-471K TND12V-511K TND12V-621K	GO	GO
TND14SE221K TND14SE241K TND14SE271K TND14SE431K TND14SE471K TND14SE511K TND14SE621K	TND14V-221K TND14V-241K TND14V-271K TND14V-431K TND14V-471K TND14V-511K TND14V-621K	GO	GO
TND20SE221K TND20SE241K TND20SE271K TND20SE431K TND20SE471K TND20SE511K TND20SE621K	TND20V-221K TND20V-241K TND20V-271K TND20V-431K TND20V-471K TND20V-511K TND20V-621K	GO	GO



SE Series

◆GENERAL SPECIFICATIONS

Operating Temperature Range: -40 to +85°C
Storage Temperature Range: -50 to +125°C

Item	Test Conditions	Specifications
Standard Test Condition	20±5°C, 65±20%RH unless specified. However, if it does not affect test result, the condition can be 20±15°C, 65±20%RH also.	
Varistor Voltage	The voltage between the two terminals measured at 1mA DC is called Varistor Voltage. The measurement shall be made as fast as possible to avoid heat affection.	Satisfy the specification
Maximum Allowable Voltage	Maximum continuous AC voltage (50 to 60Hz/AC) and maximum DC voltage which can be applied.	Satisfy the specification
Maximum Peak Surge Current	Maximum surge current (8/20µs pulse wave to be applied once, or twice, 2 minutes apart) for varistor voltage change within ±10% of the initial value.	Satisfy the specification
Energy Rating	Maximum energy (2ms square wave to be applied once) for varistor voltage change within ±10% of the initial value.	Satisfy the specification
Rated Wattage	Maximum power (50 to 60Hz/AC power to be applied for 1000 hours at 85±2°C) for varistor voltage change within ±10% of the initial value.	Satisfy the specification
Maximum Clamping Voltage	Maximum voltage across varistor when 8/20µs rated current surge is applied.	Satisfy the specification
Capacitance	Varistor's capacitance at 1kHz, standard test condition.	For reference only.
Voltage Temperature Coefficient	$\frac{V1mA \text{ at } 85^{\circ}C - V1mA \text{ at } 25^{\circ}C}{V1mA \text{ at } 25^{\circ}C} \times \frac{1}{60} \times 100 (\%/^{\circ}C)$ V1mA : Actual Varistor Voltage	Within ±0.05%/°C
Insulation	Short circuit the two leads of varistor, and put the varistor body into metal balls (1.6mm diameter) leaving 2mm epoxy coating outside. Then, apply 2.5kVrms between the leads and the metal balls for 60±5 sec..	The varistor shall withstand with no abnormality.

◆ENVIRONMENTAL CHARACTERISTICS

Item	Test Conditions	Specifications
High Temperature Storage (Dry heat)	The specimen shall be subjected 125±2°C for 1000±12 hours without load.	ΔV1mA ≤±5%
Low Temperature Storage	The specimen shall be subjected -40±2°C for 1000±12 hours without load.	ΔV1mA ≤±5%
Damp heat (Humidity)	The specimen shall be subjected to 40±2°C, 90 to 95%RH for 1000±12 hours without load.	ΔV1mA ≤±5%
Temperature Cycle	The temperature cycle shown below shall be repeated 50 cycles. -40±3°C, 30 minutes ↔ +85±2°C, 30 minutes	ΔV1mA ≤±5% ΔNo remarkable damage
High Temperature Operating	The specimen shall be subjected to 85±2°C with the maximum allowable voltage for 1000±12 hours.	ΔV1mA ≤±10%
Damp heat Operating	The specimen shall be subjected to 40±2°C, 90 to 95%RH with the maximum allowable voltage for 1000±12 hours.	ΔV1mA ≤±10%

Varistor voltage change of forward direction shall be measured in the test of unipolar surge life and DC load life.

Varistor voltage change is measured after stored at Standard Test Conditions for 1 to 2 hours.

Note : For 42V battery line, please contact our sales office.



◆MECHANICAL CHARACTERISTICS

Item	Test Conditions	Specifications												
Resistance to Soldering Heat	Each lead shall be dipped into a solder bath having a temperature of 350±10°C to a point 2.0 to 2.5 mm from the body of the unit, be held there for 3 ⁺¹ ₀ sec and then be stored at room temperature for 1 to 2 hours. The ΔV _{1mA} and mechanical damage shall be examined. or Each lead shall be dipped into a solder bath having a temperature of 260±10°C to a point 2.0 to 2.5 mm from the body of the unit, be held there for 10±1 sec and then be stored at room temperature for 1 to 2 hours. The ΔV _{1mA} and mechanical damage shall be examined.	ΔV _{1mA} ≤±5% No remarkable damage												
Solderability	Each lead shall be dipped into a methanol solution (about 25%) of rosin for 5 to 10 sec. Then each lead shall be dipped into a solder.	At least, 95% of the leads shall be covered with solder uniformly.												
	<table border="1"> <tr> <td>Solder</td> <td>Pb free (Sn-3.0Ag-0.5Cu)</td> <td>Eutectic (Sn/Pb)</td> </tr> <tr> <td>Solder Temp.</td> <td>245±5°C</td> <td>235±5°C</td> </tr> <tr> <td>Dipping Time</td> <td colspan="2">2±0.5sec.</td> </tr> <tr> <td>Dipping Depth</td> <td colspan="2">1.5 to 2.0mm (from the body)</td> </tr> </table>		Solder	Pb free (Sn-3.0Ag-0.5Cu)	Eutectic (Sn/Pb)	Solder Temp.	245±5°C	235±5°C	Dipping Time	2±0.5sec.		Dipping Depth	1.5 to 2.0mm (from the body)	
	Solder		Pb free (Sn-3.0Ag-0.5Cu)	Eutectic (Sn/Pb)										
	Solder Temp.		245±5°C	235±5°C										
Dipping Time	2±0.5sec.													
Dipping Depth	1.5 to 2.0mm (from the body)													
Lead Pull Strength	Fix varistor body, and suspend specified weight toward direction of lead axis. $\frac{\text{Lead diameter}}{\phi 0.6\text{mm}, \phi 0.8\text{mm}} \quad \frac{\text{Force}}{10 \text{ N}}$	No abnormality such as disconnection. ΔV _{1mA} ≤±5%												
Lead Bend Strength	The varistor shall be secured with its terminal kept vertical and the force specified below shall be applied in the axial direction. The terminal shall gradually be bend by 90 in one direction then back to original position. The damage of the terminal shall be visually examined. $\frac{\text{Lead diameter}}{\phi 0.6\text{mm}, \phi 0.8\text{mm}} \quad \frac{\text{Force}}{2.5 \text{ N}}$	No remarkable damage as remarkable the inner ceramic element or terminal open.												
Vibration	Mount varistor body on vibrator, and conduct the following vibration test. Peak-to-Peak amplitude : 1.5mm Vibration frequency range : 10 to 55Hz Sweeping time: Approximately one minute for 10Hz → 55Hz → 10Hz Direction and duration of vibration : Three directions of X, Y and Z. Two hours each. Six hours total.	No remarkable appearance abnormality. ΔV _{1mA} ±5%												
Flammability test	The varistor shall be subjected to 60 sec. applications of test flame. Burner : Bunsen gas burner 9000kcal / m ³ Diameter of flame nozzle : φ9.5 mm Position : The specimen shall be fixed horizontal. Point of application shall be approximately center of the specimen.	No catching fire, and no flaming drops.												

SV Series



Our newly developed TNR SV series is to prevent from being caught fire even very high surge energy is applied. Thus electric appliance using TNR SV series can be much safer like TNR SE series.

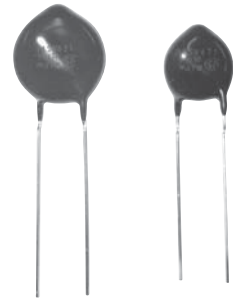

◆FEATURES

- Coating resin is highly non-flammability.
- Coating resin doesn't burn under the flammability test of UL.
- Little scatter at the destruction under over voltage.
- Pb free for RoHS directives.
- Halogen free (Coating resin doesn't contain Halogen).
- Strong to thermal shock (-40°C -85°C, 100 cycles).
- UL, CSA and VDE recognized components
 UL1449 3rd File : E323623
 UL1414 File : E65426 (Except "12SV")
 CSA File : LR97864
 VDE File : 118623

◆APPLICATIONS

- Protection for semiconductors from over voltage.
- Protection for electronic instruments from lightning surge.
- Absorption of on-off surge from motors and relays.

Operating Temperature Range: -40 to +85°C
 Storage Temperature Range: -50 to +125°C

◆PART NUMBERING SYSTEM

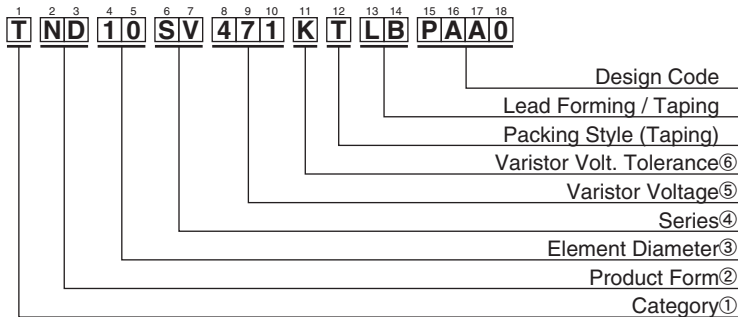

①Category	
T	Metal Oxide Varistors TNR

②Product Form	
ND	Disk Type

③Element Diameter	
10	φ10 mm
12	φ12 mm
14	φ14 mm

④Series	
SV	SV Series

⑤Varistor Voltage
The first two digits are significant figures and the third one denotes the number of following zeros.

⑥Varistor Volt. Tolerance	
K	±10%

◆CAUTIONS and WARNINGS

Varistors may be short-circuit or be destroyed, in case of absorbing over rating voltage or over rating surge. Please connect a current fuse less than 7A rating or a circuit breaker in series with varistors.



SV Series

◆ RATINGS AND CHARACTERISTICS

Part Number	Previous Part Number (Just for your reference)	Maximum Ratings					Max. Clamping Voltage		Capacitance Typical @1kHz	Varistor Voltage V _{1mA}	Thickness T MAX.
		Max. Allowable Voltage		Max. Peak Current	Max. Energy	Rated Wattage	(A)	(V)			
		AC (Vrms)	DC (V)	8/20μs(A)	2ms(J)	(W)			(pF)	(V)	
TND10SV221KTLBPAA0	TNR10SV221K317-T71	140	180	3,500A/1 time	27.5	0.4	25	360	450	220 (198~242)	6.4
TND10SV241KTLBPAA0	TNR10SV241K317-T71	150	200		30			395	400	240 (216~264)	6.5
TND10SV271KTLBPAA0	TNR10SV271K317-T71	175	225		35			455	350	270 (247~303)	6.7
TND10SV431KTLBPAA0	TNR10SV431K317-T71	275	350	2,500A/2 times	55	0.6	50	710	240	430 (387~473)	7.5
TND10SV471KTLBPAA0	TNR10SV471K317-T71	300	385		60			775	220	470 (423~517)	7.7
TND10SV511KTLBPAA0	TNR10SV511K317-T71	320	410		67			845	210	510 (459~561)	7.9
TND10SV621KTLBPAA0	TNR10SV621K317-T71	385	505	67	67		1025	180	620 (558~682)	8.6	
TND12SV431KTLBPAA0	TNR12SV431K317-T71	275	350	4,200A/1 time	55	0.4	25	710	240	430 (387~473)	7.5
TND12SV471KTLBPAA0	TNR12SV471K317-T71	300	385		60			775	220	470 (423~517)	7.7
TND12SV511KTLBPAA0	TNR12SV511K317-T71	320	410		67			845	210	510 (459~561)	7.9
TND12SV621KTLBPAA0	TNR12SV621K317-T71	385	505	3,000A/2 times	67		1025	180	620 (558~682)	8.6	
TND14SV221KTLBPAA0	TNR14SV221K317-T71	140	180	6,000A/1 time	55	0.6	50	360	850	220 (198~242)	6.4
TND14SV241KTLBPAA0	TNR14SV241K317-T71	150	200		60			395	800	240 (216~264)	6.5
TND14SV271KTLBPAA0	TNR14SV271K317-T71	175	225		70			455	700	270 (247~303)	6.7
TND14SV431KTLBPAA0	TNR14SV431K317-T71	275	350	5,000A/2 times	110	0.6	50	710	460	430 (387~473)	7.5
TND14SV471KTLBPAA0	TNR14SV471K317-T71	300	385		125			775	420	470 (423~517)	7.7
TND14SV511KTLBPAA0	TNR14SV511K317-T71	320	410		136			845	390	510 (459~561)	7.9
TND14SV621KTLBPAA0	TNR14SV621K317-T71	385	505	5,000A/1 time 4,500A/2 times	136		1,025	330	620 (558~682)	8.6	

◆ DIMENSIONS [mm]

TND10SV/TND12SV/TND14SV : Taping Products only

Taping Code: TLB

Symbol	10SV	12SV	14SV
D	13.0 MAX.	15.0 MAX.	16.5 MAX.
φd	0.8±0.05	←	←
P	15.0±1.0	15.0±1.0	30.0±1.0
P0	15.0±0.3	←	←
φD0	4.0±0.2	←	←
P1	3.75±0.5	←	←
W1	9.0±0.5	←	←
F0	7.5±0.8	←	←
Δh	0±2.0	←	←
ΔP	0±1.3	←	←
W	18.0±1.0	←	←
W0	5.0 MIN.	←	←
W2	3.0 MAX.	←	←
t	0.6±0.3	←	←
H	20.0 MAX.	25.0 MAX.	27.0 MAX.
H0	19.0±1.0	←	←
H1	46.5 MAX.	←	47.0 MAX.
J	6.0 MAX.	←	←

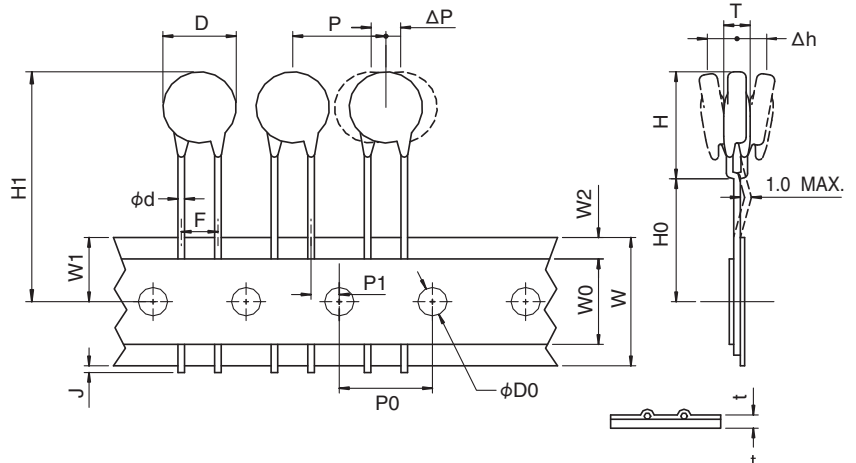

◆ MARKING

EX)

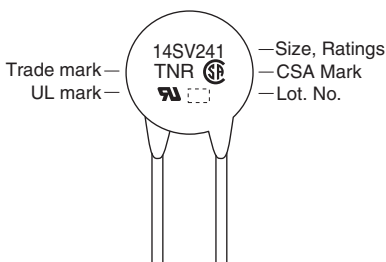



SV Series

◆V-I CURVE and PULSE LIFE TIME RATINGS

V-I characteristics and PULSE LIFE TIME RATINGS are same as those of V series.
Please see V-I CURVE and PULSE LIFE TIME RATINGS of V series.

CROSS REFERENCE TABLE

TNR SE SERIES	TNR V SERIES	V-I CURVE GO TO REF. PAGE	PULSE LIFE TIME RATINGS GO TO REF. PAGE
TND10SV221KTLBPAA0 TND10SV241KTLBPAA0 TND10SV271KTLBPAA0 TND10SV431KTLBPAA0 TND10SV471KTLBPAA0 TND10SV511KTLBPAA0 TND10SV621KTLBPAA0	TND10V-221K TND10V-241K TND10V-271K TND10V-431K TND10V-471K TND10V-511K TND10V-621K		
TND12SV431KTLBPAA0 TND12SV471KTLBPAA0 TND12SV511KTLBPAA0 TND12SV621KTLBPAA0	TND12V-431K TND12V-471K TND12V-511K TND12V-621K		
TND14SV221KTLBPAA0 TND14SV241KTLBPAA0 TND14SV271KTLBPAA0 TND14SV431KTLBPAA0 TND14SV471KTLBPAA0 TND14SV511KTLBPAA0 TND14SV621KTLBPAA0	TND14V-221K TND14V-241K TND14V-271K TND14V-431K TND14V-471K TND14V-511K TND14V-621K		



SV Series

◆GENERAL SPECIFICATIONS

Operating Temperature Range: -40 to +85°C
Storage Temperature Range: -50 to +125°C

Item	Test Conditions	Specifications
Standard Test Condition	20±5°C, 65±20%RH unless specified. However, if it does not affect test result, the condition can be 20±15°C, 65±20%RH also.	
Varistor Voltage	The voltage between the two terminals measured at 1mA DC is called Varistor Voltage. The measurement shall be made as fast as possible to avoid heat affection.	Satisfy the specification
Maximum Allowable Voltage	Maximum continuous AC voltage (50 to 60Hz/AC) and maximum DC voltage which can be applied.	Satisfy the specification
Maximum Peak Surge Current	Maximum surge current (8/20µs pulse wave to be applied once, or twice, 2 minutes apart) for varistor voltage change within ±10% of the initial value.	Satisfy the specification
Energy Rating	Maximum energy (2ms square wave to be applied once) for varistor voltage change within ±10% of the initial value.	Satisfy the specification
Rated Wattage	Maximum power (50 to 60Hz/AC power to be applied for 1000 hours at 85±2°C) for varistor voltage change within ±10% of the initial value.	Satisfy the specification
Maximum Clamping Voltage	Maximum voltage across varistor when 8/20µs rated current surge is applied.	Satisfy the specification
Capacitance	Varistor's capacitance at 1kHz, standard test condition.	For reference only.
Voltage Temperature Coefficient	$\frac{V1mA \text{ at } 85^{\circ}C - V1mA \text{ at } 25^{\circ}C}{V1mA \text{ at } 25^{\circ}C} \times \frac{1}{60} \times 100 (\%/^{\circ}C)$ V1mA : Actual Varistor Voltage	Within ±0.05%/°C
Insulation	Short circuit the two leads of varistor, and put the varistor body into metal balls (1.6mm diameter) leaving 2mm epoxy coating outside. Then, apply 2.5kVrms between the leads and the metal balls for 60±5 sec..	The varistor shall withstand with no abnormality.

◆ENVIRONMENTAL CHARACTERISTICS

Item	Test Conditions	Specifications
High Temperature Storage (Dry heat)	The specimen shall be subjected 125±2°C for 1000±12 hours without load.	ΔV1mA ≤±5%
Low Temperature Storage	The specimen shall be subjected -40±2°C for 1000±12 hours without load.	ΔV1mA ≤±5%
Damp heat (Humidity)	The specimen shall be subjected to 40±2°C, 90 to 95%RH for 1000±12 hours without load.	ΔV1mA ≤±5%
Temperature Cycle	The temperature cycle shown below shall be repeated 100 cycles. -40±3°C, 30 minutes ↔ +85±2°C, 30 minutes	ΔV1mA ≤±5% ΔNo remarkable damage
High Temperature Operating	The specimen shall be subjected to 85±2°C with the maximum allowable voltage for 1000±12 hours.	ΔV1mA ≤±10%
Damp heat Operating	The specimen shall be subjected to 40±2°C, 90 to 95%RH with the maximum allowable voltage for 1000±12 hours	ΔV1mA ≤±10%

Varistor voltage change of forward direction shall be measured in the test of unipolar surge life and DC load life.

Varistor voltage change is measured after stored at Standard Test Conditions for 1 to 2 hours.

Note : For 42V battery line, please contact our sales office.



◆MECHANICAL CHARACTERISTICS

Item	Test Conditions	Specifications												
Resistance to Soldering Heat	Each lead shall be dipped into a solder bath having a temperature of 350±10°C to a point 2.0 to 2.5 mm from the body of the unit, be held there for 3 ⁺¹ ₀ sec and then be stored at room temperature for 1 to 2 hours. The ΔV _{1mA} and mechanical damage shall be examined. or Each lead shall be dipped into a solder bath having a temperature of 260±10°C to a point 2.0 to 2.5 mm from the body of the unit, be held there for 10±1 sec and then be stored at room temperature for 1 to 2 hours. The ΔV _{1mA} and mechanical damage shall be examined.	ΔV _{1mA} ≤±5% No remarkable damage												
Solderability	Each lead shall be dipped into a methanol solution (about 25%) of rosin for 5 to 10 sec. Then each lead shall be dipped into a solder.	At least, 95% of the leads shall be covered with solder uniformly.												
	<table border="1"> <tr> <td>Solder</td> <td>Pb free (Sn-3.0Ag-0.5Cu)</td> <td>Eutectic (Sn/Pb)</td> </tr> <tr> <td>Solder Temp.</td> <td>245±5°C</td> <td>235±5°C</td> </tr> <tr> <td>Dipping Time</td> <td colspan="2">2±0.5sec.</td> </tr> <tr> <td>Dipping Depth</td> <td colspan="2">1.5 to 2.0mm (from the body)</td> </tr> </table>		Solder	Pb free (Sn-3.0Ag-0.5Cu)	Eutectic (Sn/Pb)	Solder Temp.	245±5°C	235±5°C	Dipping Time	2±0.5sec.		Dipping Depth	1.5 to 2.0mm (from the body)	
	Solder		Pb free (Sn-3.0Ag-0.5Cu)	Eutectic (Sn/Pb)										
	Solder Temp.		245±5°C	235±5°C										
Dipping Time	2±0.5sec.													
Dipping Depth	1.5 to 2.0mm (from the body)													
Lead Pull Strength	Fix varistor body, and suspend specified weight toward direction of lead axis. $\frac{\text{Lead diameter}}{\phi 0.6\text{mm}, \phi 0.8\text{mm}} \quad \frac{\text{Force}}{10 \text{ N}}$	No abnormality such as disconnection. ΔV _{1mA} ≤±5%												
Lead Bend Strength	The varistor shall be secured with its terminal kept vertical and the force specified below shall be applied in the axial direction. The terminal shall gradually be bend by 90 in one direction then back to original position. The damage of the terminal shall be visually examined. $\frac{\text{Lead diameter}}{\phi 0.6\text{mm}, \phi 0.8\text{mm}} \quad \frac{\text{Force}}{2.5 \text{ N}}$	No remarkable damage as remarkable the inner ceramic element or terminal open.												
Vibration	Mount varistor body on vibrator, and conduct the following vibration test. Peak-to-Peak amplitude : 1.5mm Vibration frequency range : 10 to 55Hz Sweeping time: Approximately one minute for 10Hz → 55Hz → 10Hz Direction and duration of vibration : Three directions of X, Y and Z. Two hours each. Six hours total.	No remarkable appearance abnormality. ΔV _{1mA} ±5%												
Flammability test	The varistor shall be subjected to 60 sec. applications of test flame. Burner : Bunsen gas burner 9000kcal / m ³ Diameter of flame nozzle : φ9.5 mm Position : The specimen shall be fixed horizontal. Point of application shall be approximately center of the specimen.	No catching fire, and no flaming drops.												

Operating Temperature Range: -40 to +125°C
Storage Temperature Range: -50 to +150°C

◆STANDARD RATINGS

Part Number	Previous Part Number (Just for your reference)	Max. Allowable Voltage		Maximum applicable voltage for a short period	Max. Energy	Max. Clamping Voltage		Varistor Voltage V _{1mA}
		Continuous		5 minutes		(A)	(V)	
		AC (V _{rms})	DC (V)	DC (V)				
TND09H-220KB00AAA0	TNR9H220K	12	16	24	5	2	43	22 (20~24)
TND09H-270KB00AAA0	TNR9H270K	15	19	29				27 (24~30)
TND09H-330KB00AAA0	TNR9H330K	18	24	36				33 (30~36)
TND09H-390KB00AAA0	TNR9H390K	22	28	42				39 (35~43)
TND09H-470KB00AAA0	TNR9H470K	26	34	50				47 (42~52)
TND12H-220KB00AAA0	TNR12H220K	12	16	24	10	5	43	22 (20~24)
TND12H-270KB00AAA0	TNR12H270K	15	19	29				27 (24~30)
TND12H-330KB00AAA0	TNR12H330K	18	24	36				33 (30~36)
TND12H-390KB00AAA0	TNR12H390K	22	28	42				39 (35~43)
TND12H-470KB00AAA0	TNR12H470K	26	34	50				47 (42~52)
TND15H-220KB00AAA0	TNR15H220K	12	16	24	20	10	43	22 (20~24)
TND15H-270KB00AAA0	TNR15H270K	15	19	29				27 (24~30)
TND15H-330KB00AAA0	TNR15H330K	18	24	36				33 (30~36)
TND15H-390KB00AAA0	TNR15H390K	22	28	42				39 (35~43)
TND15H-470KB00AAA0	TNR15H470K	26	34	50				47 (42~52)
TND23H-220KB00AAA0	TNR23H220K	12	16	24	40	25	43	22 (20~24)
TND23H-270KB00AAA0	TNR23H270K	15	19	29				27 (24~30)
TND23H-330KB00AAA0	TNR23H330K	18	24	36				33 (30~36)
TND23H-390KB00AAA0	TNR23H390K	22	28	42				39 (35~43)
TND23H-470KB00AAA0	TNR23H470K	26	34	50				47 (42~52)

◆DIMENSIONS [mm]

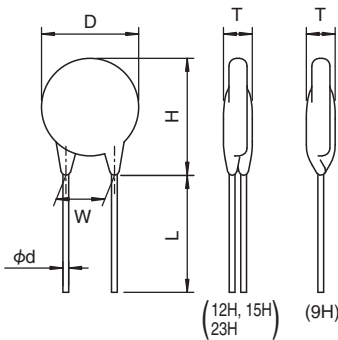

Type	D Max.	H Max.	T Max.	W ±1.0	L Min.	φd ±0.05
9H	10.0	14.0	5.0	5.0	25.0	0.6
12H	14.0	17.0	5.0	7.5	25.0	0.8
15H	17.0	20.0	5.0	7.5	25.0	0.8
23H	24.0	28.0	5.0	10.0	25.0	0.8

◆MARKING

EX)

●9H

●12H~23H

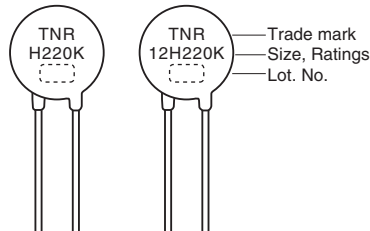

H Series

◆V-I CURVE

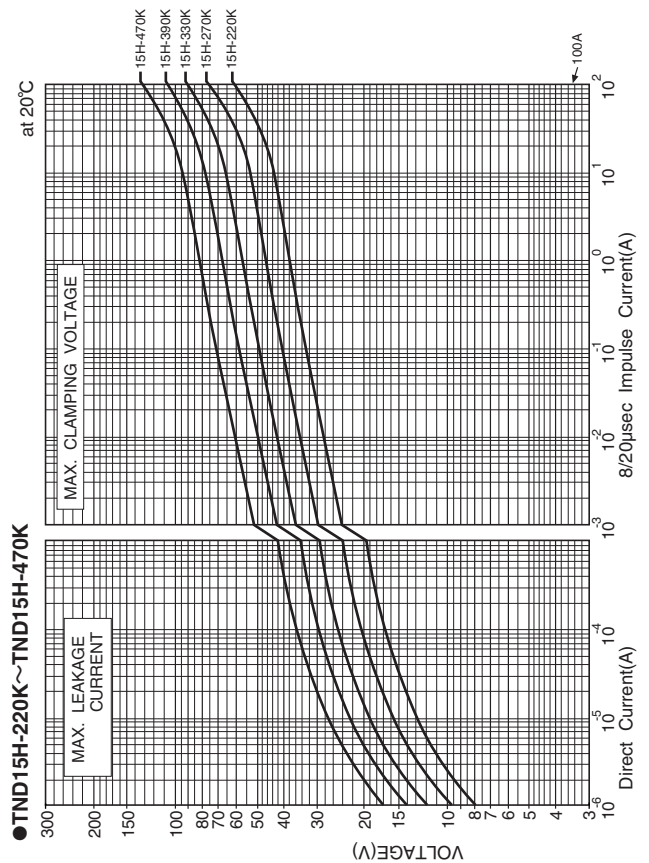
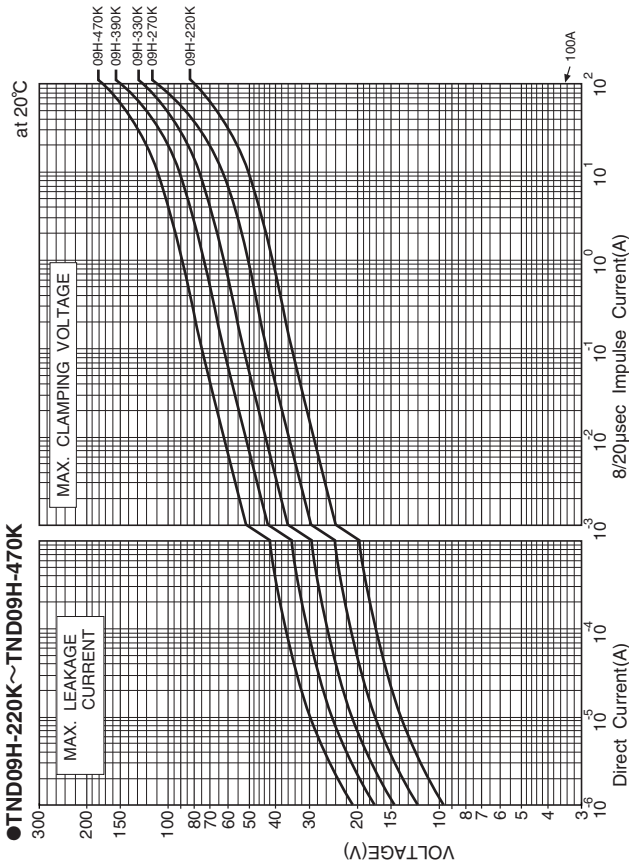
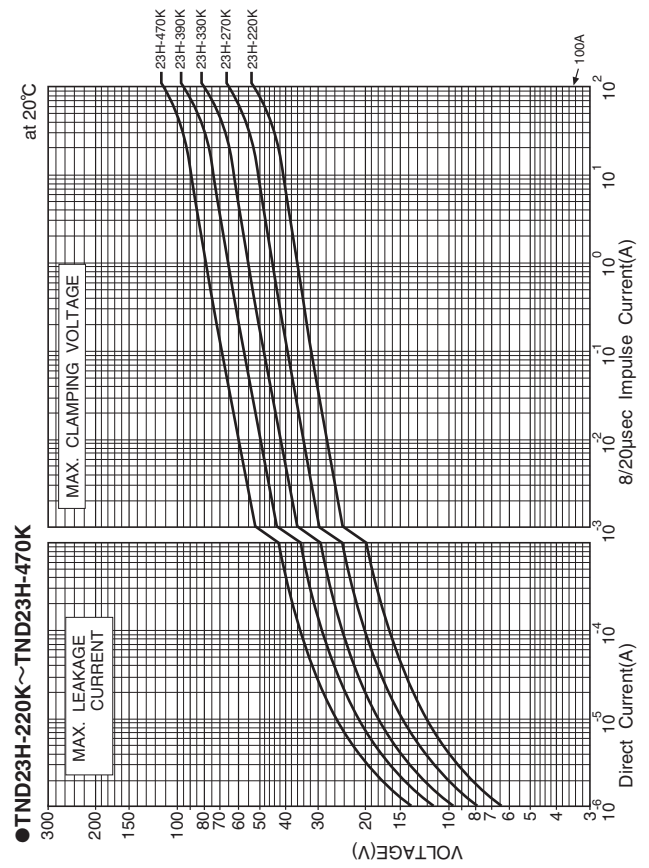
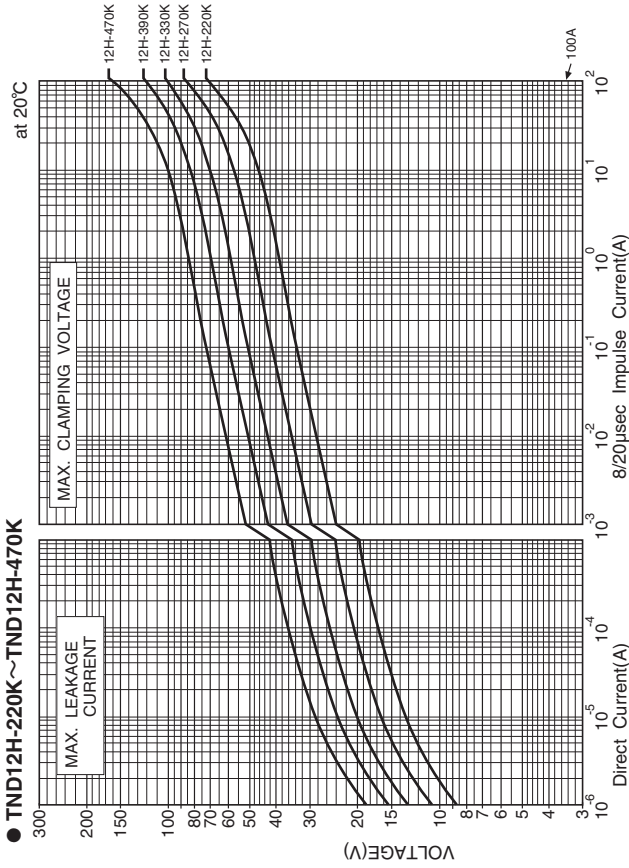



H Series

◆GENERAL SPECIFICATIONS

Operating Temperature Range: -40 to +125°C
Storage Temperature Range: -50 to +150°C

Item	Test Conditions	Specifications
Standard Test Condition	Ambient temperature : 20±15°C Relative humidity : 65±20%RH if there is any doubt about the results, measurement shall be made within the following limits. Ambient temperature : 20±5°C Relative humidity : 65±20%RH	
Varistor Voltage	The voltage between the two terminals measured at 1mA DC is called Varistor Voltage. The measurement shall be made as fast as possible to avoid heat affection.	Satisfy the specification.
Maximum Allowable Voltage	Maximum continuous sinusoidal RMS voltage or Maximum continuous DC voltage which may be applied.	Refer to Ratings.
Maximum applicable voltage for a short period (5 minutes)	Maximum DC voltage to be applied for only 5 minutes.	Refer to Ratings.
Maximum Clamping Voltage	The maximum voltage between the terminals, measured standard impulse current (8/20 μs).	Satisfy the specification.
Maximum Energy	Maximum energy within the ±10% varistor voltage change when 1 impulse 20 ms long is applied.	Satisfy the specification.
Temperature Coefficient	$\frac{V_{1mA \text{ at } 85^\circ\text{C}} - V_{1mA \text{ at } 25^\circ\text{C}}}{V_{1mA \text{ at } 25^\circ\text{C}}} \times \frac{1}{60} \times 100 (\%/^\circ\text{C})$	Within ±0.05 % / °C

◆MECHANICAL CHARACTERISTICS

Item	Test Conditions	Specifications												
Terminal Pull Strength	After gradually applying the force keeping the unit fixed for 10±1 sec. in axial direction, the damage of the terminals shall be visually examined. $\frac{\text{Lead diameter}}{\phi 0.6\text{mm. } \phi 0.8\text{mm}} \quad \frac{\text{Force}}{10 \text{ N}}$	$\Delta V_{1mA} \leq \pm 5\%$ No remarkable damage												
Terminal Bending Strength	The unit shall be secured with its terminal kept vertical and the weight specified below be applied in the axial direction. The terminal shall gradually be bend by 90° in one direction then 90° in the opposite direction, and again back to original position. The damage of the terminal shall be visually examined. $\frac{\text{Lead diameter}}{\phi 0.6\text{mm. } \phi 0.8\text{mm}} \quad \frac{\text{Force}}{5 \text{ N}}$	No remarkable damage												
Vibration	After repeatedly applying a single harmonic vibration (amplitude : 0.75mm) double amplitude : 1.5mm with 1 minute vibration frequency cycle (10Hz → 500Hz → 10Hz) to each three perpendicular directions for 2 hours. Total 6 hours. The devices shall be visually examined.	$\Delta V_{1mA} \leq \pm 5\%$ No remarkable damage												
Resistance to Soldering Heat	Each lead shall be dipped into a solder bath having a temperature of 350±10°C to a point 2.0 to 2.5 mm from the body of the unit, be held there for 3 ₀ ⁺ sec and then be stored at room temperature for 1 to 2 hours. The ΔV _{1mA} and mechanical damage shall be examined. or Each lead shall be dipped into a solder bath having a temperature of 260±10°C to a point 2.0 to 2.5 mm from the body of the unit, be held there for 10±1 sec and then be stored at room temperature for 1 to 2 hours. The ΔV _{1mA} and mechanical damage shall be examined.	$\Delta V_{1mA} \leq \pm 5\%$ No remarkable damage												
Solderability	Each lead shall be dipped into a methanol solution (about 25%) of rosin for 5 to 10 sec. Then each lead shall be dipped into a solder. <table border="1" style="width: 100%; border-collapse: collapse;"> <tr> <td>Solder</td> <td>Pb free (Sn-3.0Ag-0.5Cu)</td> <td>Eutectic (Sn/Pb)</td> </tr> <tr> <td>Solder Temp.</td> <td>245±5°C</td> <td>235±5°C</td> </tr> <tr> <td>Dipping Time</td> <td colspan="2">2±0.5sec.</td> </tr> <tr> <td>Dipping Depth</td> <td colspan="2">1.5 to 2.0mm (from the body)</td> </tr> </table>	Solder	Pb free (Sn-3.0Ag-0.5Cu)	Eutectic (Sn/Pb)	Solder Temp.	245±5°C	235±5°C	Dipping Time	2±0.5sec.		Dipping Depth	1.5 to 2.0mm (from the body)		At least, 95% of the leads shall be covered with solder uniformly.
Solder	Pb free (Sn-3.0Ag-0.5Cu)	Eutectic (Sn/Pb)												
Solder Temp.	245±5°C	235±5°C												
Dipping Time	2±0.5sec.													
Dipping Depth	1.5 to 2.0mm (from the body)													



H Series

◆ ENVIRONMENTAL CHARACTERISTICS

Item	Test Conditions	Specifications
High Temperature Storage (Dry heat)	The specimen shall be subjected 150±2°C for 1000±12 hours without load.	$\Delta V1mA \leq \pm 10\%$
Low Temperature Storage	The specimen shall be subjected -40±2°C for 1000±12 hours without load.	$\Delta V1mA \leq \pm 5\%$
Damp heat (Humidity)	The specimen shall be subjected to 60±2°C, 90 to 95%RH for 1000±12 hours without load.	$\Delta V1mA \leq \pm 10\%$
Temperature Cycle	The temperature cycle shown below shall be repeated 50 cycles. -40±3°C, 30 minutes \leftrightarrow +150±2°C, 30 minutes	$\Delta V1mA \leq \pm 10\%$ Δ No remarkable damage
High Temperature Operating	The specimen shall be subjected to 125±2°C with the maximum allowable voltage for 1000±12 hours.	$\Delta V1mA \leq \pm 20\%$
Damp heat Operating	The specimen shall be subjected to 60±2°C, 90 to 95%RH with the maximum allowable voltage for 1000±12 hours.	$\Delta V1mA \leq \pm 10\%$

Varistor voltage change of forward direction shall be measured in the test of unipolar surge life and DC load life.

Varistor voltage change is measured after stored at Standard Test Conditions for 1 to 2 hours.

Note : For 42V battery line, please contact our sales office.

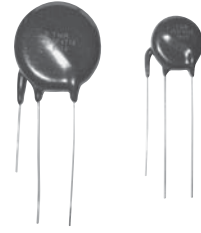

Operating Temperature Range: -40 to +85°C
Storage Temperature Range: -50 to +125°C

◆STANDARD RATINGS

Part Number	Previous Part Number (Just for your reference)	Maximum Ratings					Max. Clamping Voltage V50A (V)	Capacitance Typical @1kHz (pF)	Varistor Voltage V1mA (V)	T Max. (mm)	E ±1.0 (mm)
		Max. Allowable Voltage		Max. Peak Current	Max. Energy	Rated Wattage					
15GF Type		AC(Vrms)	DC(V)	8/20μs(A)	2ms(J)	(W)					
TND15GF271KB00EAA0	TNR15GF271K-E	175	225	2500A/2 times	50	0.6	440	680	270 (243~297)	9	1.5
TND15GF471KB00EAA0	TNR15GF471K-E	300	385		80	0.6	765	450	470 (423~517)	10	2.2
TND15GF821KB00EAA0	TNR15GF821K-E	510	670		110	0.6	1340	280	820 (738~902)	12	3.5
23GF Type		AC (Vrms)	DC (V)	8/20μs(A)	2ms(J)	(W)	V50A (V)	(pF)	(V)	(mm)	(mm)
TND23GF271KB00EAA0	TNR23GF271K-E	175	225	4000A/2 times	90	0.8	440	1850	270 (243~297)	9	1.5
TND23GF471KB00EAA0	TNR23GF471K-E	300	385		150	1.0	765	1200	470 (423~517)	10	2.3
TND23GF821KB00EAA0	TNR23GF821K-E	510	670		190	1.5	1340	800	820 (738~902)	12	3.6

◆DIMENSIONS [mm]

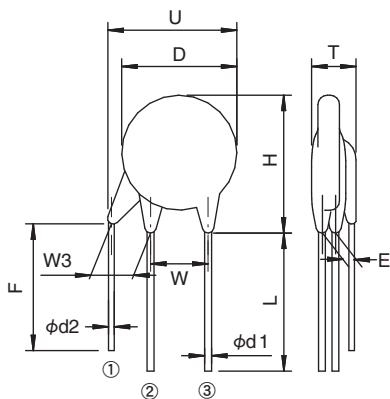

	15GF	23GF
D	18 Max.	25 Max.
T	Refer to Standard Ratings	
H	22 Max.	32 Max.
W	7.5±1	10±1
W3	2.5 Min.	2.5 Min.
L	25 Min.	25 Min.
U	23 Max.	28 Max.
F	17 Min.	17 Min.
E	Refer to Standard Ratings	
φd1	0.8±0.05	0.8±0.05
φd2	0.53±0.05	0.58±0.05

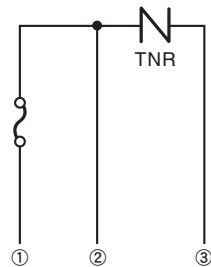

Type	Thermal fuse ratings
15GF	145°C-250V-1A
23GF	145°C-250V-3A

◆MARKING

EX)

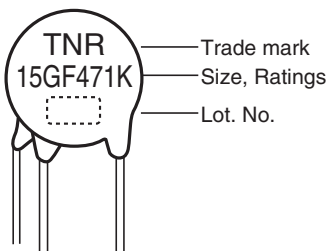



METAL OXIDE VARISTORS TNR™

32HP Series

High Peak Current with tabs



STANDARD RATINGS

Operating Temperature Range: -40 to +85°C

Storage Temperature Range: -50 to +125°C

Part Number	Previous Part Number (Just for your reference)	Maximum Ratings				Max. Clamping Voltage V200A (V)	Capacitance Typical @1kHz (pF)	Varistor Voltage V1mA (V)	
		Max. Allowable Voltage		Max. Peak Current	Max. Energy				
		AC (Vrms)	DC (V)	8/20μs(kA)	2ms(J)				
TNT32HP221KB00AAA0	TNR32HP221K310	140	180	25000A/1 time 20000A/2 times	200	1.2	360	5500	220 (198~ 242)
TNT32HP241KB00AAA0	TNR32HP241K310	150	200		240		395	4800	240 (216~ 264)
TNT32HP271KB00AAA0	TNR32HP271K310	175	225		260		445	4200	270 (243~ 297)
TNT32HP391KB00AAA0	TNR32HP391K310	250	320		350		650	3500	390 (351~ 429)
TNT32HP431KB00AAA0	TNR32HP431K310	275	350		400		710	2700	430 (387~ 473)
TNT32HP471KB00AAA0	TNR32HP471K310	300	385		410		775	2600	470 (423~ 517)
TNT32HP511KB00AAA0	TNR32HP511K310	315	420		420		840	2400	510 (459~ 561)
TNT32HP681KB00AAA0	TNR32HP681K310	420	560		450		1120	2100	680 (612~ 748)
TNT32HP751KB00AAA0	TNR32HP751K310	460	615		500		1240	2000	750 (675~ 825)
TNT32HP821KB00AAA0	TNR32HP821K310	510	670		545		1355	1800	820 (738~ 902)
TNT32HP911KB00AAA0	TNR32HP911K310	550	745	600	1500	1700	910 (819~1001)		
TNT32HP102KB00AAA0	TNR32HP102K310	625	825	620	1650	1000	1000 (900~1100)		
TNT32HP112KB00AAA0	TNR32HP112K310	680	895	640	1815	800	1100 (990~1210)		

DIMENSIONS [mm]

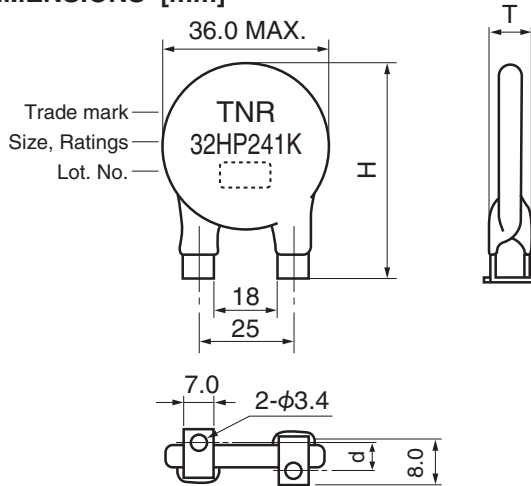

Part Number	H Max.	T Max.	d ±1.0
TNT32HP221KB00AAA0	46.0	7.5	6.8
TNT32HP241KB00AAA0	46.0	7.5	6.7
TNT32HP271KB00AAA0	46.0	7.5	6.5
TNT32HP391KB00AAA0	46.0	7.5	5.8
TNT32HP431KB00AAA0	46.0	7.5	5.6
TNT32HP471KB00AAA0	46.0	7.5	5.4
TNT32HP511KB00AAA0	46.0	10.0	5.2
TNT32HP681KB00AAA0	46.0	10.0	4.2
TNT32HP751KB00AAA0	46.0	10.0	3.9
TNT32HP821KB00AAA0	46.0	10.0	3.5
TNT32HP911KB00AAA0	46.0	10.0	3.0
TNT32HP102KB00AAA0	46.0	11.0	2.5
TNT32HP112KB00AAA0	46.0	11.0	1.9

V-I CURVE

●TNT32HP221K~TNT32HP112K

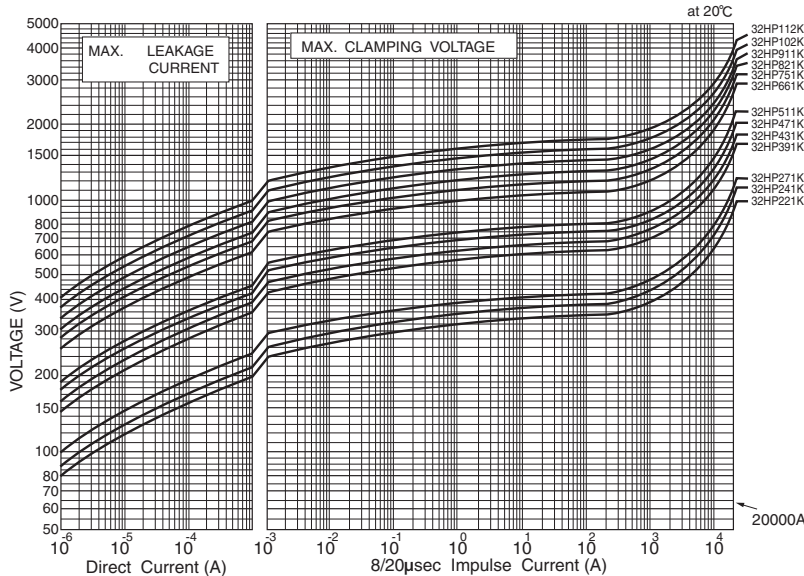

PULSE LIFE TIME RATINGS

●TNT32HP221K~TNT32HP112K

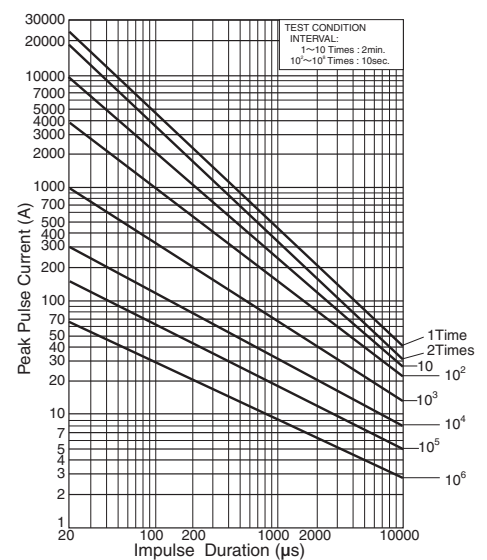



METAL OXIDE VARISTORS TNR™

A Series



High Varistor Voltage (Axial Lead Type)



Operating Temperature Range -40 to +85°C
Storage Temperature Range -50 to +105°C

Part Number	Previous Part Number (Just for your reference)	Maximum Ratings					Max. Clamping Voltage V _{2A} (V)	Varistor Voltage V _{0.1mA} (V)	H Max. (mm)
		Max. Allowable Voltage		Max. Peak Current	Max. Energy	Rated Wattage			
4A Type		AC (Vrms)	DC (V)	8/20μs(A)	2ms(J)	(W)			
TNL04A-122KB00AAA0	TNR4A122K	620	880		1.8	0.05	2200	1200 (1080~ 1320)	11
TNL04A-152KB00AAA0	TNR4A152K	780	1100	40A/1 time	2.0		2600	1500 (1350~ 1650)	12
TNL04A-182KB00AAA0	TNR4A182K	930	1300	20A/2 times	2.5		3100	1800 (1620~ 1980)	13
TNL04A-202KB00AAA0	TNR4A202K	1040	1450		3.0		3500	2000 (1800~ 2200)	15
10A Type		AC (Vrms)	DC (V)	8/20μs(A)	2ms(J)	(W)	V _{5A} (V)	(V)	(mm)
TNL10A-472KB00AAA0	TNR10A472K	2200	3100		10	0.5	8700	4700 (4230~ 5170)	40
TNL10A-562KB00AAA0	TNR10A562K	2600	3700		10		10000	5600 (5040~ 6160)	
TNL10A-682KB00AAA0	TNR10A682K	3200	4500	100A/1 time	10		12000	6800 (6120~ 7480)	50
TNL10A-822KB00AAA0	TNR10A822K	3900	5500	50A/2 times	10		16000	8200 (7380~ 9020)	
TNL10A-103KB00AAA0	TNR10A103K	4700	6700		15	19500	10000 (9000~11000)	55	
TNL10A-123KB00AAA0	TNR10A123K	5700	8100		15	21500	12000 (10800~13200)		

◆DIMENSIONS [mm]

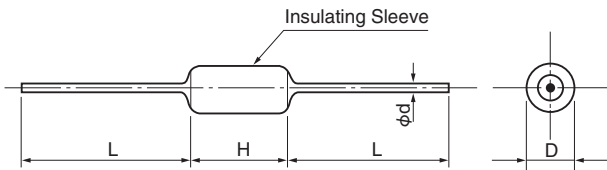

Type	4A Type	10A Type
D	4±1	10±1
L	25 Min.	30 Min.
φd	0.6	1

◆MARKING

EX)

4A Type

10A Type



Trade mark
Ratings
Lot. No.

◆V-I CURVE

●TNL04A-122K~202K

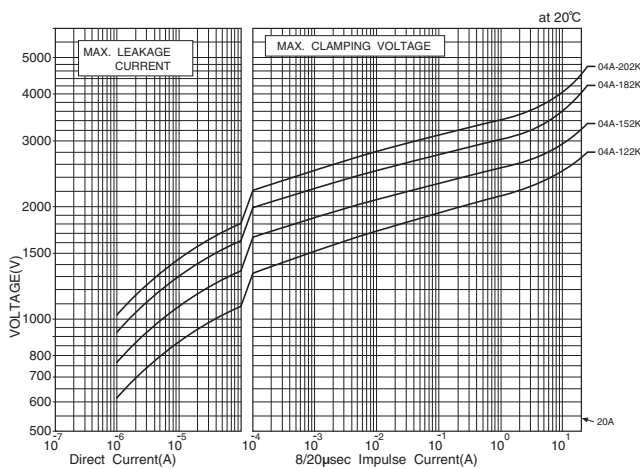

◆V-I CURVE

●TNL10A-472K~123K

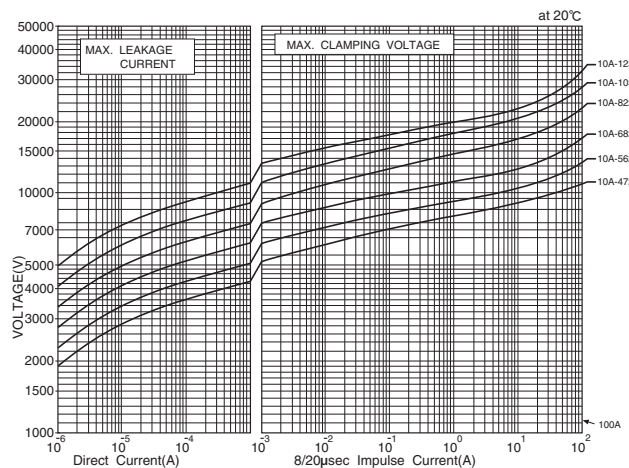



METAL OXIDE VARISTORS TNR™

E Series

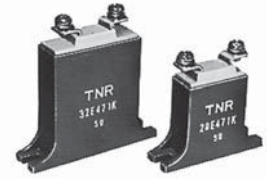

◆FEATURES

- Excellent clamping voltage characteristic and fast response time (<50 ns) when subjected to impulse surges.
- No follow current.
- Any voltage rating within a V1mA range from 200 to 1100V available. (V1mA : varistor voltage.)
- Bilateral and symmetrical V- I characteristics curve.
- The TNR can, therefore, be used both in AC and DC circuits, for protection of either positive or negative transients.
- Large withstanding peak current 8000 to 25000A(8/20μs).

◆APPLICATIONS

- Protection of semiconductors such as transistors, diodes, ICs, thyristors, triacs, etc.
- Protection of various equipment including:
 - *Broadcasting, communications equipment.
 - *Traffic and railway signal systems.
 - *Automatic control devices for power distribution.
 - *Waterworks.
 - *Home entertainment equipment.
- Surge absorption of relays and electromagnetic valves.
- Absorption of surges generated within equipment such as TVs.

◆DIMENSIONS [mm (in.)]

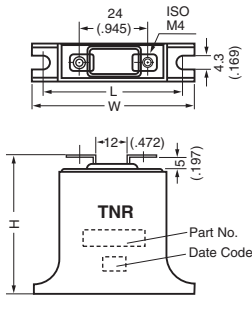

Type	W	H	L
20E	48±1 (1.890±0.039)	42±1 (1.653±0.039)	39±1 (1.535±0.039)
32E	60±1 (2.362±0.039)	55±1 (2.165±0.039)	51±1 (2.008±0.039)

Operating Temperature Range -40 to +85°C
Storage Temperature Range -40 to +110°C

Part Number	Previous Part Number (Just for your reference)	Maximum Ratings					Max. Clamping Voltage V _{100A} (V)	Capacitance Typical @1kHz (pF)	Varistor Voltage V _{1mA} (V)
		Max. Allowable Voltage		Max. Peak Current	Max. Energy	Rated Wattage			
20E Series		AC (Vrms)	DC (V)	8/20μs (kA)	2ms (J)	(W)			
TNB20E-221KB00AAA0	TNR20E221K	140	180	8000A/1 time	80	0.8	360	2200	220 (198~ 242)
TNB20E-241KB00AAA0	TNR20E241K	150	200		95		395	1500	240 (216~ 264)
TNB20E-271KB00AAA0	TNR20E271K	175	225		100		445	1400	270 (243~ 297)
TNB20E-391KB00AAA0	TNR20E391K	250	320		130		650	1200	390 (351~ 429)
TNB20E-431KB00AAA0	TNR20E431K	275	350		140		710	1000	430 (387~ 473)
TNB20E-471KB00AAA0	TNR20E471K	300	385		150		775	950	470 (423~ 517)
TNB20E-511KB00AAA0	TNR20E511K	315	420		160		840	930	510 (459~ 561)
TNB20E-681KB00AAA0	TNR20E681K	420	560		175		1120	850	680 (612~ 748)
TNB20E-751KB00AAA0	TNR20E751K	460	615		190		1240	800	750 (675~ 825)
TNB20E-821KB00AAA0	TNR20E821K	510	670		215		1355	700	820 (738~ 902)
TNB20E-911KB00AAA0	TNR20E911K	550	745	240	1500	600	910 (819~1001)		
TNB20E-102KB00AAA0	TNR20E102K	625	825	245	1650	400	1000 (900~1100)		
TNB20E-112KB00AAA0	TNR20E112K	680	895	250	1815	350	1100 (990~1210)		
32E Series		AC (Vrms)	DC (V)	8/20μs (kA)	2ms (J)	(W)	V _{200A} (V)	(pF)	(V)
TNB32E-221KB00AAA0	TNR32E221K	140	180	25000A/1 time	200	1.2	360	5500	220 (198~ 242)
TNB32E-241KB00AAA0	TNR32E241K	150	200		240		395	4800	240 (216~ 264)
TNB32E-271KB00AAA0	TNR32E271K	175	225		260		445	4200	270 (243~ 297)
TNB32E-391KB00AAA0	TNR32E391K	250	320		350		650	3500	390 (351~ 429)
TNB32E-431KB00AAA0	TNR32E431K	275	350		400		710	2700	430 (387~ 473)
TNB32E-471KB00AAA0	TNR32E471K	300	385		410		775	2600	470 (423~ 517)
TNB32E-511KB00AAA0	TNR32E511K	315	420		420		840	2400	510 (459~ 561)
TNB32E-681KB00AAA0	TNR32E681K	420	560		450		1120	2100	680 (612~ 748)
TNB32E-751KB00AAA0	TNR32E751K	460	615		500		1240	2000	750 (675~ 825)
TNB32E-821KB00AAA0	TNR32E821K	510	670		545		1355	1800	820 (738~ 902)
TNB32E-911KB00AAA0	TNR32E911K	550	745	600	1500	1700	910 (819~1001)		
TNB32E-102KB00AAA0	TNR32E102K	625	825	620	1650	1000	1000 (900~1100)		
TNB32E-112KB00AAA0	TNR32E112K	680	895	640	1815	800	1100 (990~1210)		

Product specifications in this catalog are subject to change without notice. Request our product specifications before purchase and/or use. Please use our products based on the information contained in this catalog and product specifications.



E Series

◆V-I CURVE

●TNB20E-221K~112K

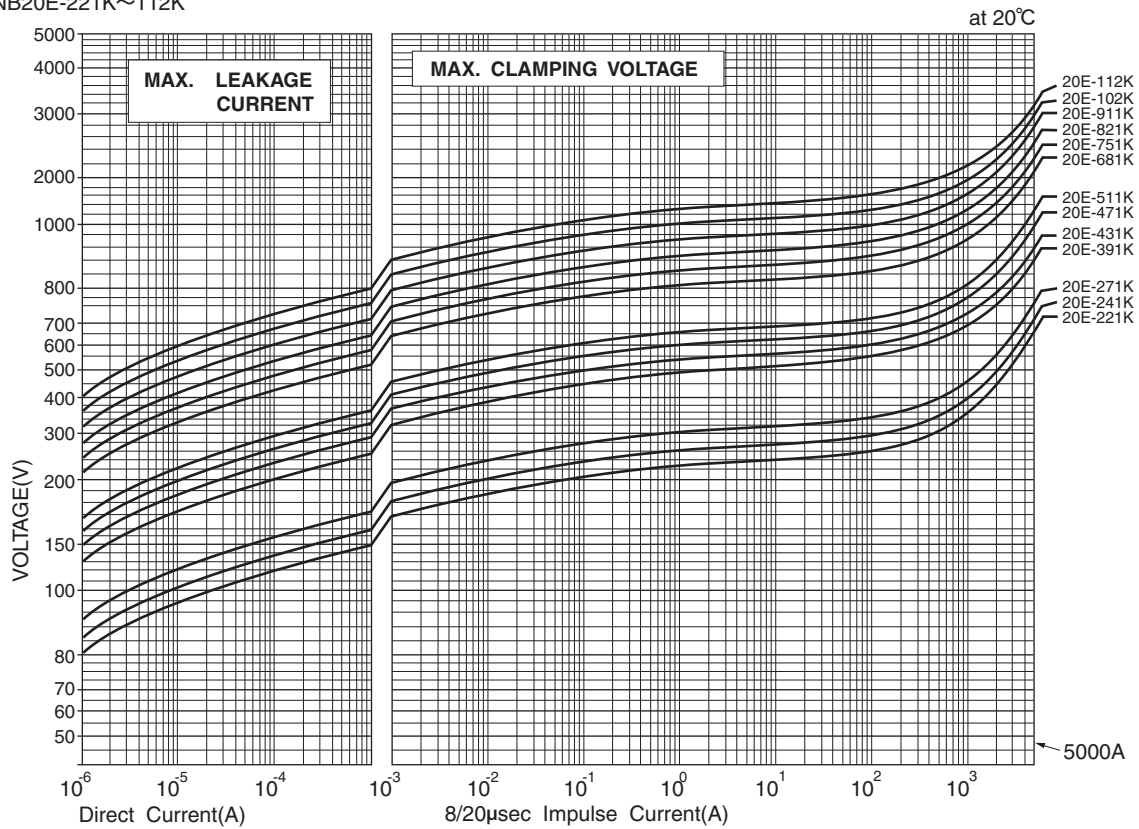

●TNB32E-221K~112K

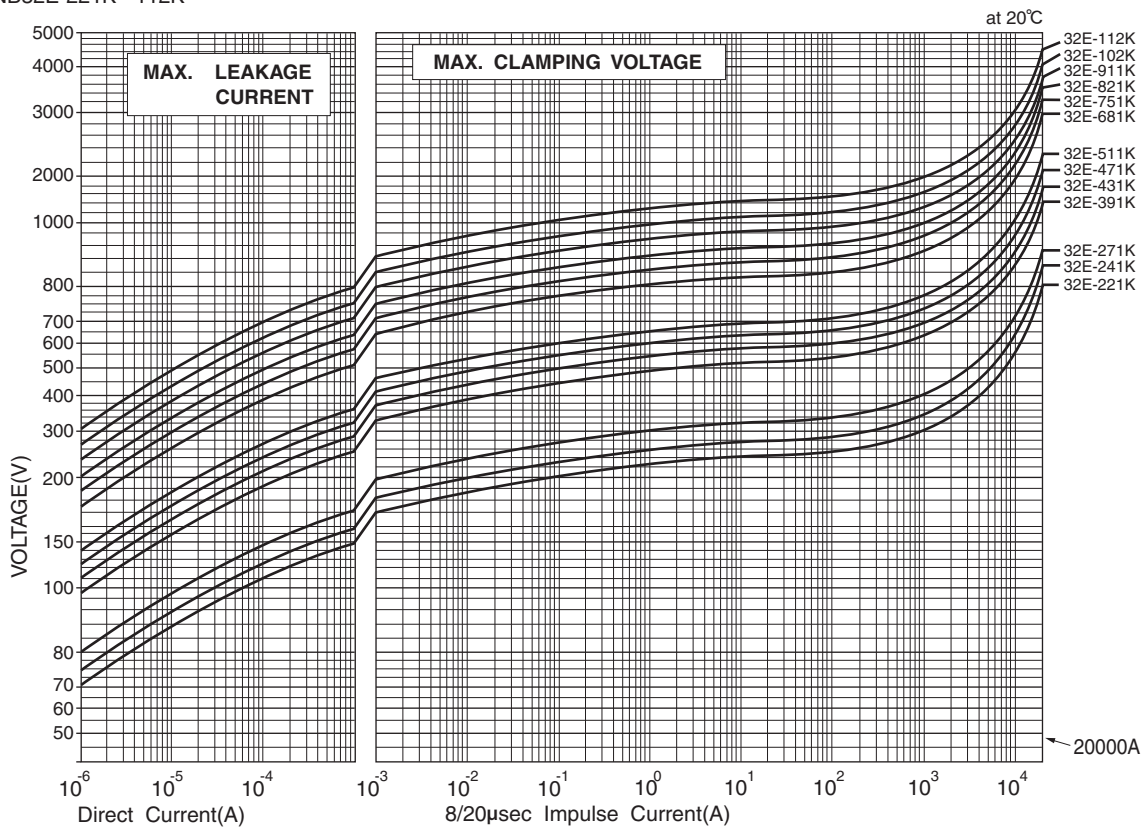

PULSE LIFE TIME RATINGS

When the following factors are different from the specified conditions, the peak pulse current should be revised based on the PULSE LIFE TIME RATINGS.

- Impulse duration time
- Number of impulse

(Impulse Current Wave Form)

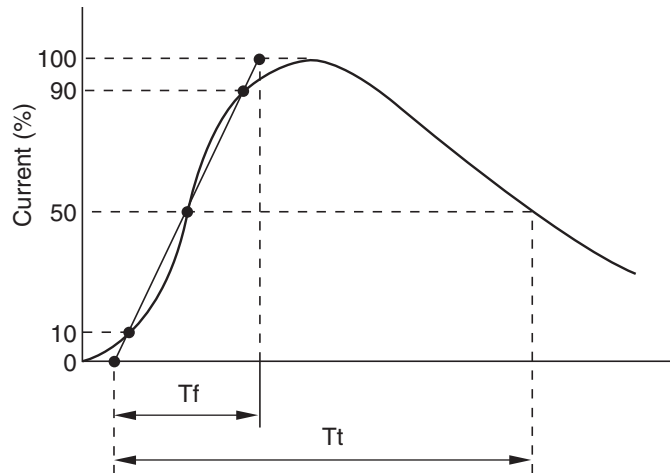

Tf : (Rise Time)

Tt : (Impulse Duration)

●V series

PULSE LIFE TIME RATINGS
(TND05V-180K~680K)

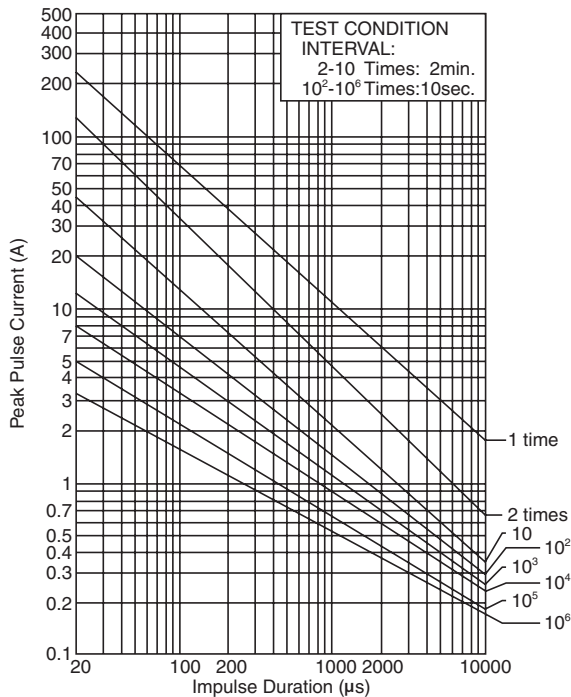

PULSE LIFE TIME RATINGS
(TND05V-820K~471K)

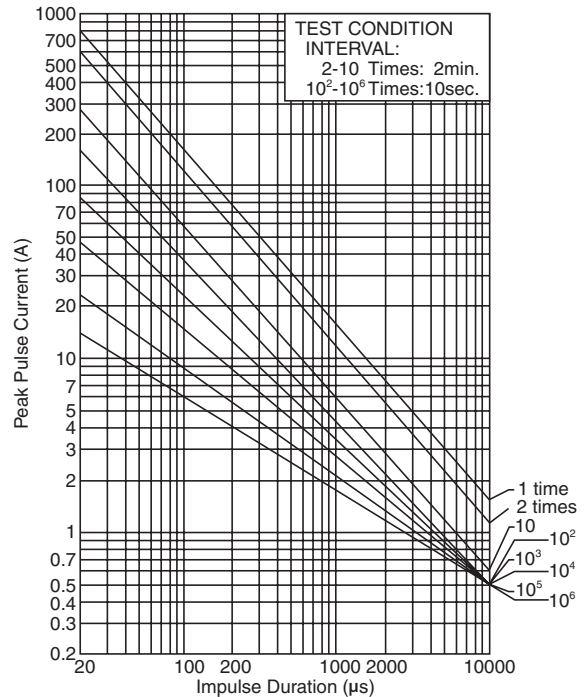



●V series

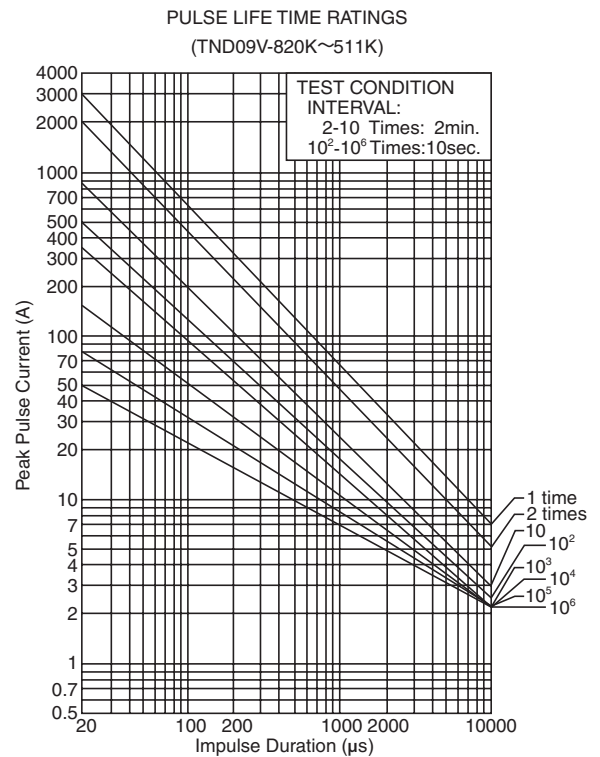
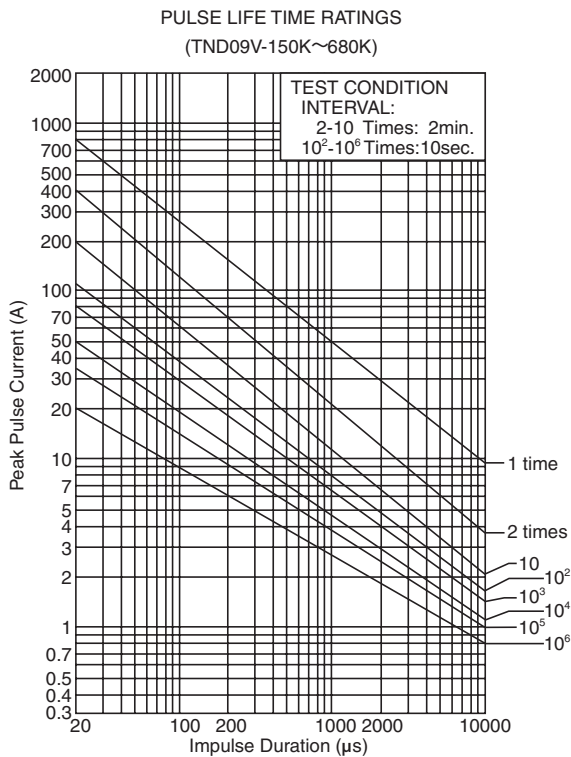
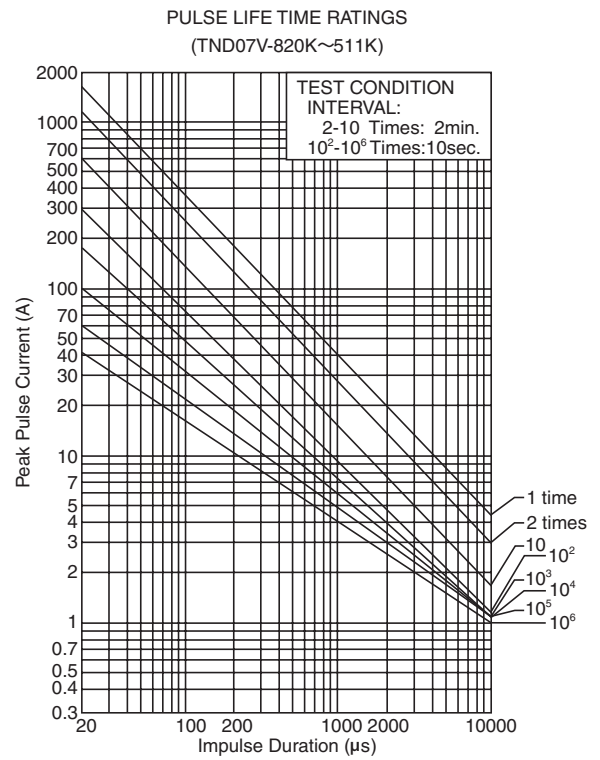
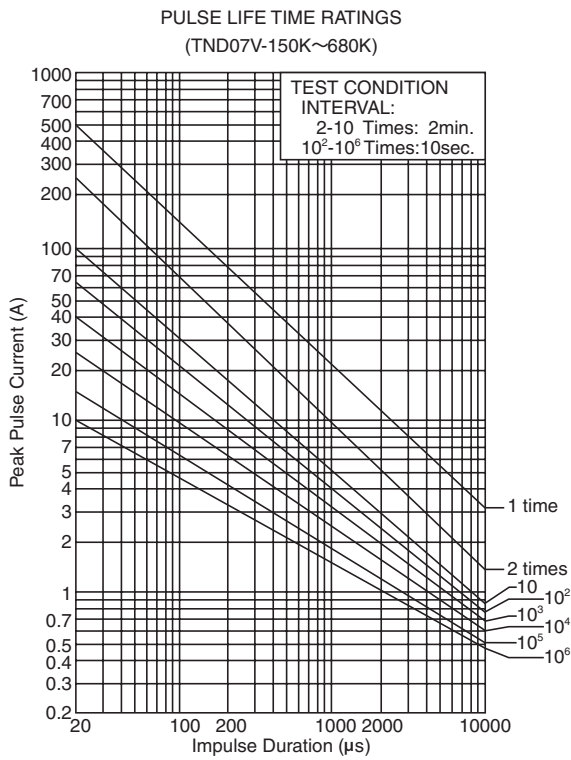

● V series

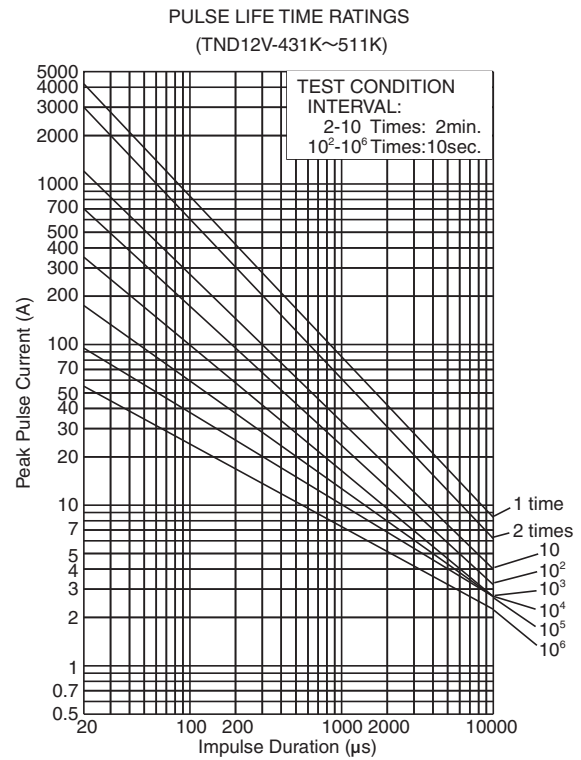
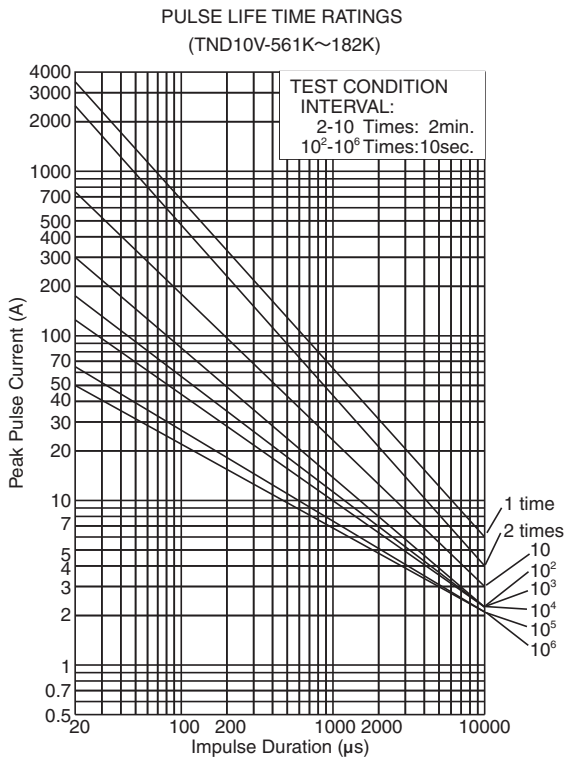
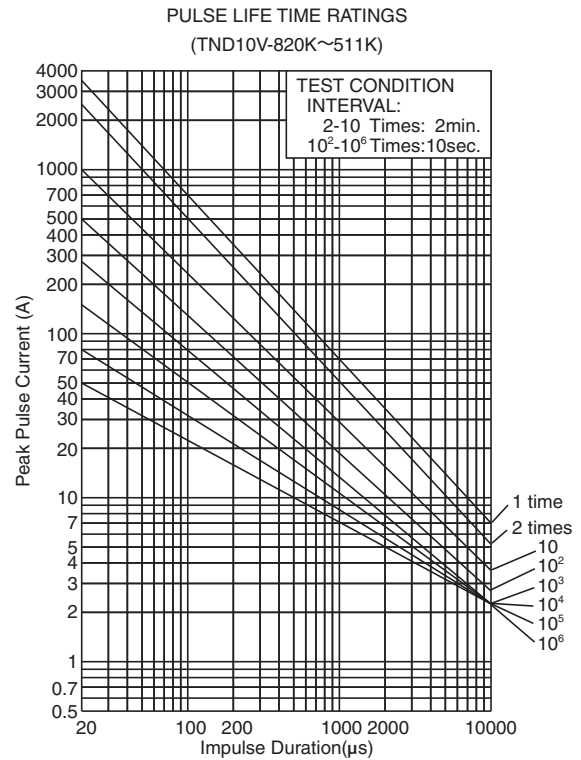
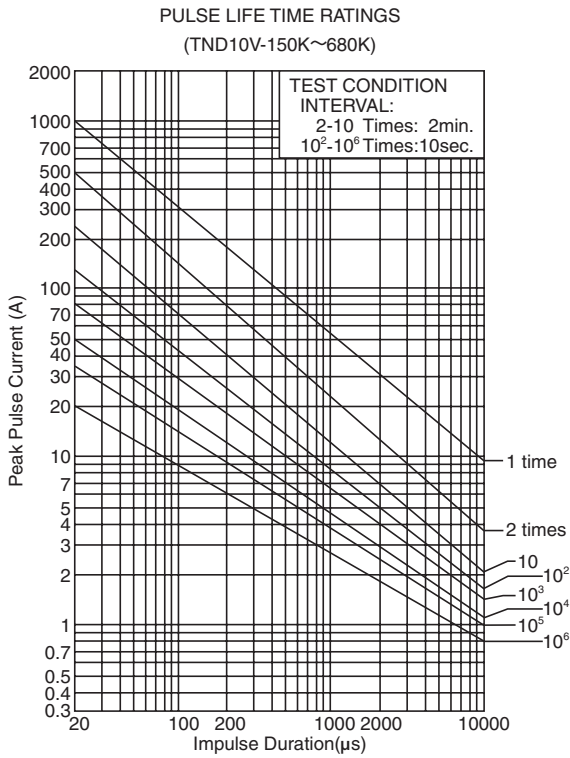



●V series

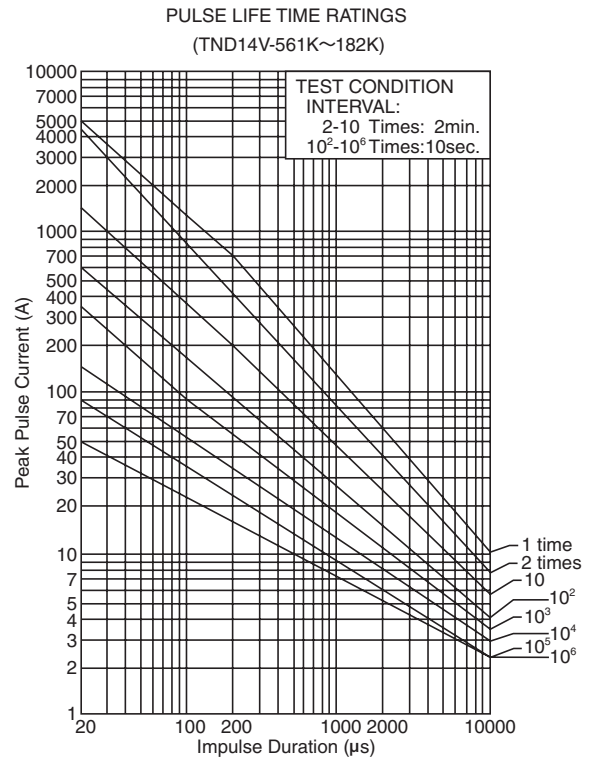
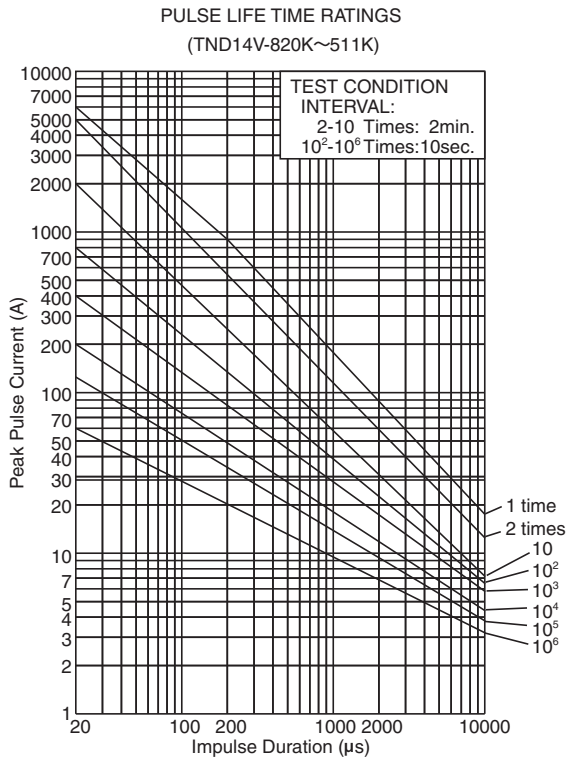
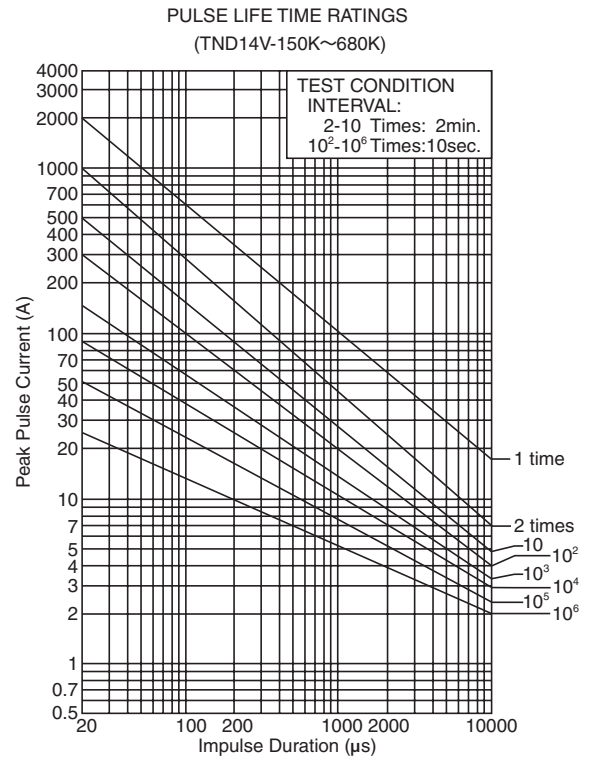
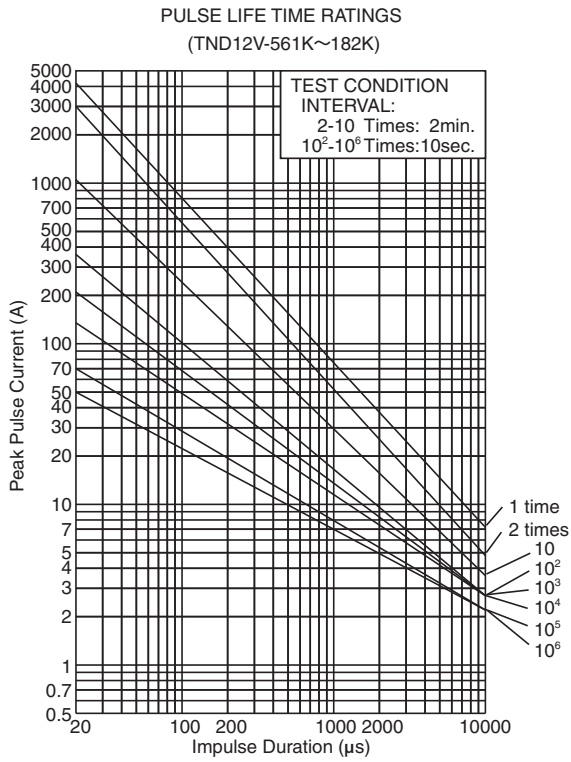



●V series

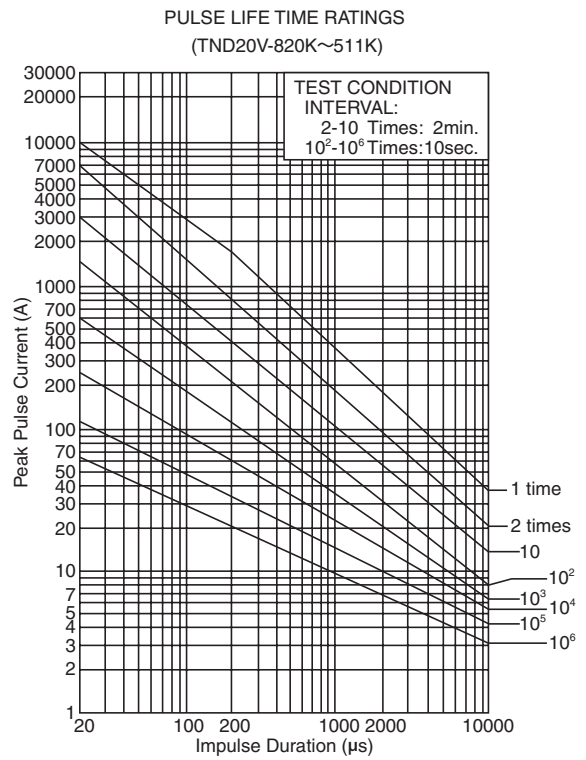
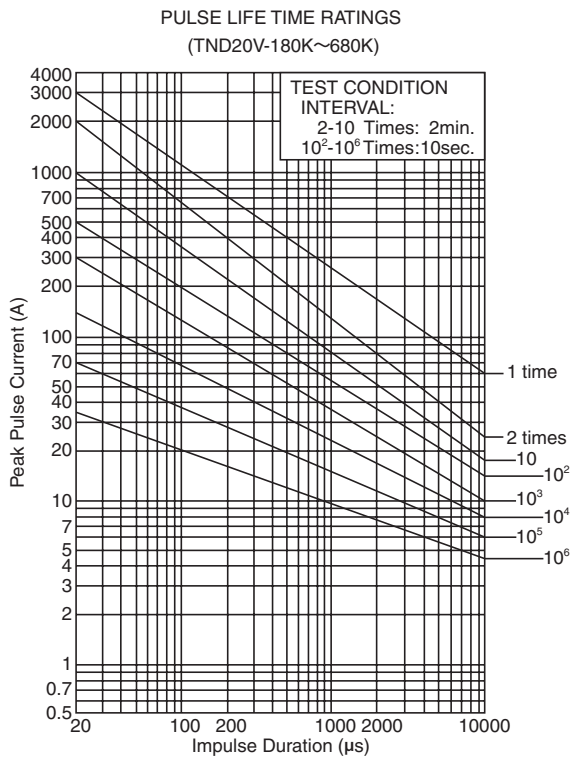

●V series

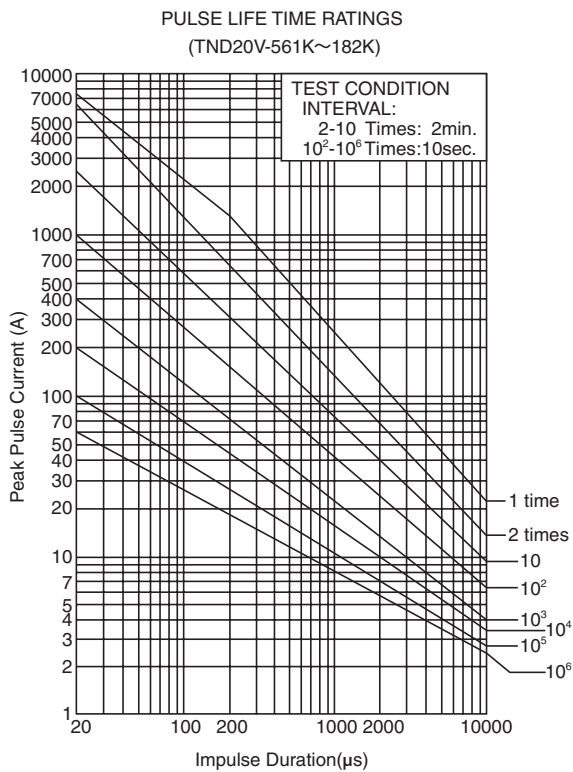

●32HP series

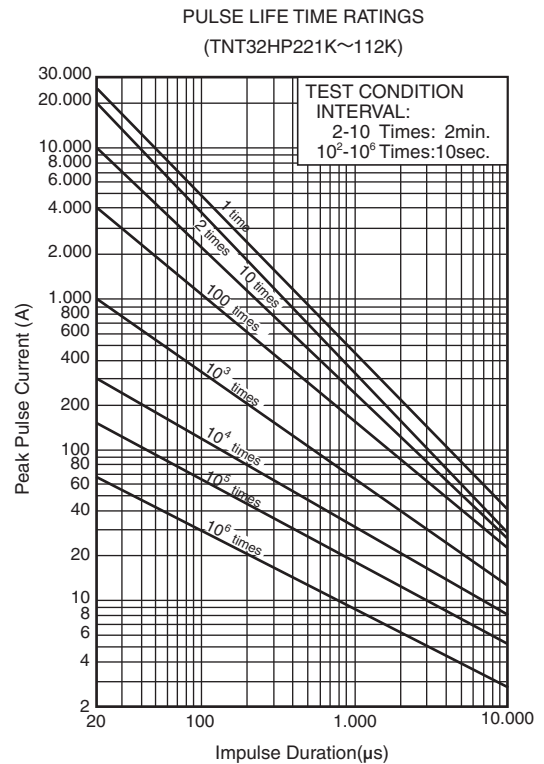

●A series

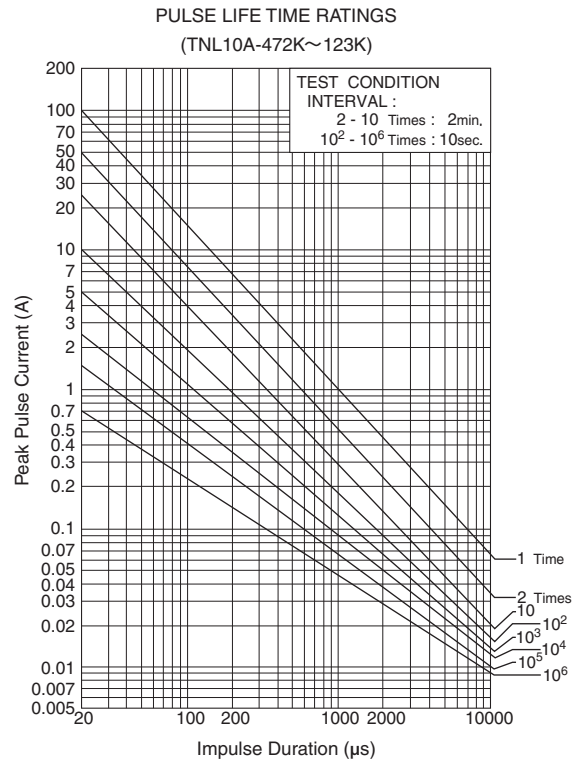
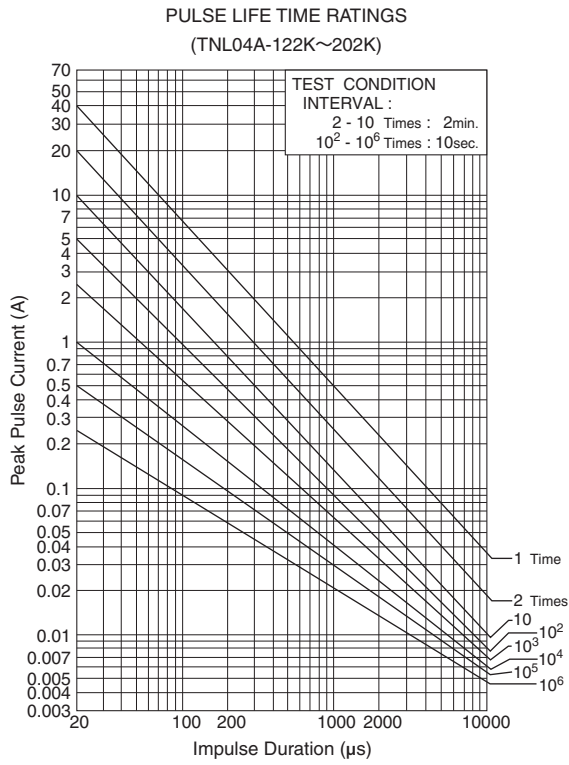

●E series

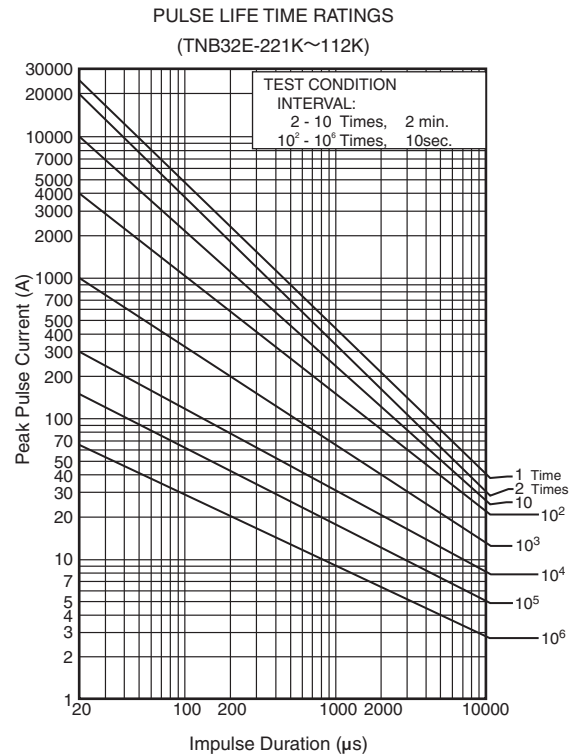
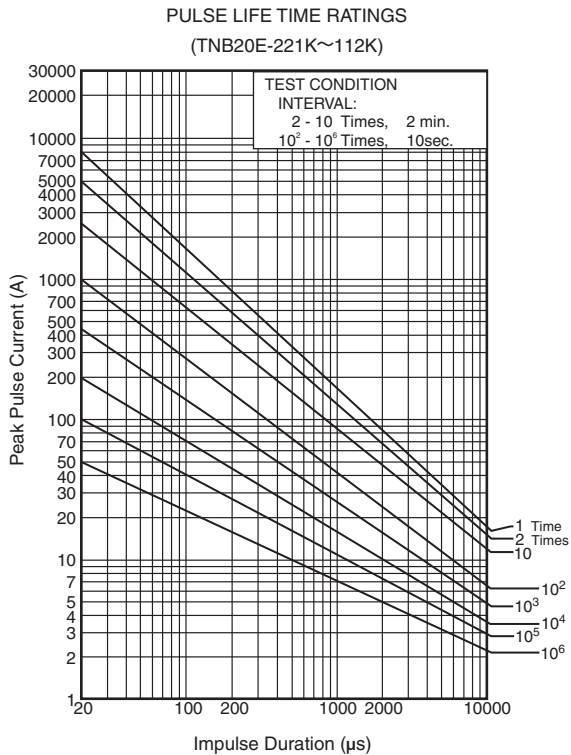

(1) Power Source Circuit

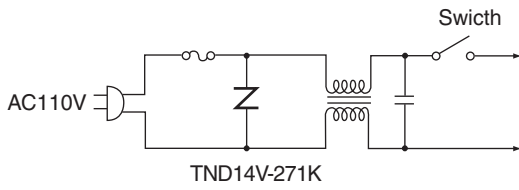

(2) Micro Computer Equipment

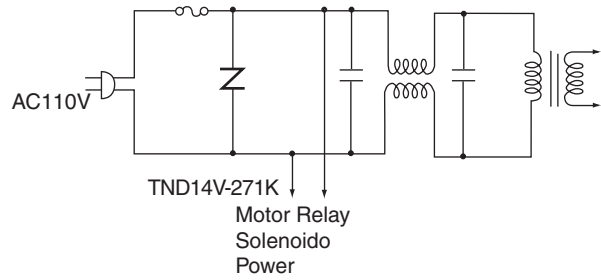

(3) Vending Machine

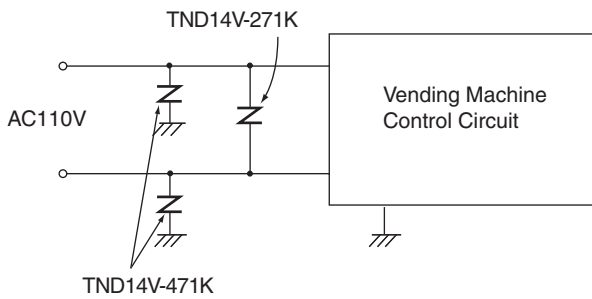

(4) Leakage Current Detector

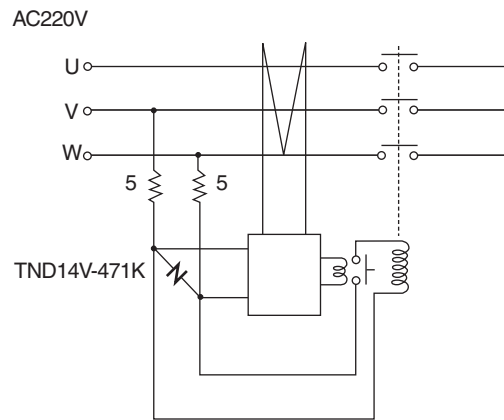

(5) Maganetic Brake

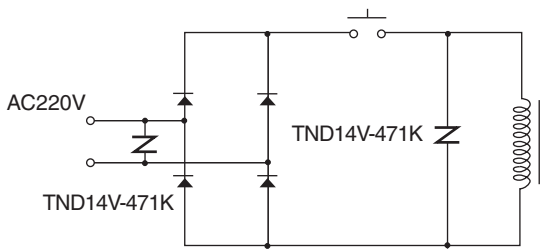

(6) Control of 20kW DC Motor

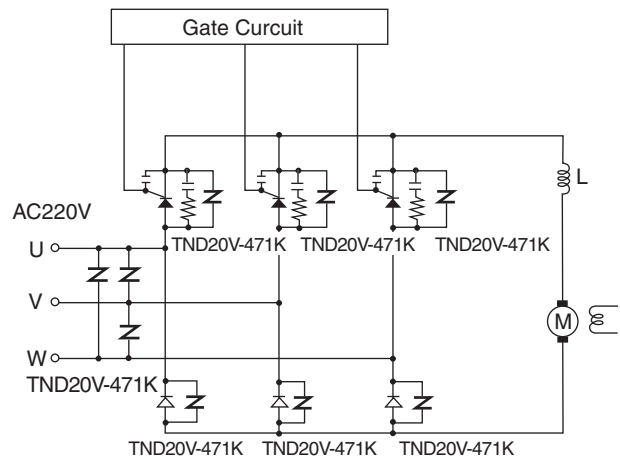

(7) Telephone

