



MULTILAYER CERAMIC CAPACITORS

CAT. No. E1002P

INDEX			
PRODUCT SEARCH	SERIES TABLE	➔	
PRODUCTION GUIDE	PRECAUTIONS AND GUIDELINES	➔	
	PART NUMBERING SYSTEM	➔	
	PACKAGING	➔	
	MINIMUM ORDER QUANTITY	➔	
PRODUCT SPECIFICATIONS	CHIP TYPE	NTS Series	➔
		NTF Series	➔
		THC Series	➔
		TMC Series	➔
	METAL CAP TYPE	NTJ Series	➔
		THP Series	➔
		TMP Series	➔
	RADIAL LEAD TYPE	NTD Series	➔
THD Series		➔	
CHARACTERISTICS DATA		➔	



Item	Series	Rated Voltage Range (V _{dc})	Rated Capacitance Range(μF)	Temperature Characteristics	RoHS Compliant
Chip Type	^(Upgrade!) NTS	25 to 250	0.033 to 33	ΔC/C 25°C=±15% -55°C to +125°C (X7R : EIA)	Compliant
Chip Type	^(Upgrade!) NTF	25 to 250	0.033 to 33		
Metal cap Type	^(New!) NTJ	25 to 250	1.5 to 47		
Lead Type	^(Upgrade!) NTD	25 to 250	0.1 to 33		
Chip Type	THC	25 to 200	0.047 to 47	ΔC/C 20°C=-55 to +20% -25°C to +85°C (E : JIS) ΔC/C 25°C=-56 to +22% -30°C to +85°C (Y5U : EIA) ΔC/C 25°C=-82 to +22% -55°C to +125°C (X7V : EIA)	Compliant : Tin plating, Silver(THC) terminal (Terminal code : N0,R0)
	TMC	25 to 200	0.033 to 10		
Metal cap Type	THP	25 to 200	0.45 to 100		Compliant : Silver plating terminal (Terminal code : 5□)
	TMP	25 to 200	1.5 to 100		
Lead Type	THD	25 to 250	0.1 to 470		Compliant

1 In designing device circuits

- (1) Confirming the installation and operating environment of capacitors, use them within the rated performance limits prescribed in their catalog or product specifications. Otherwise, excessive use conditions cause the capacitors to have catastrophic failure such as short circuit, open circuit or firing.
- (2) Do not apply a DC voltage which exceeds the full rated voltage. The peak voltage of a superimposed AC voltage (ripple voltage) on the DC voltage must not exceed the full rated voltage.
- (3) By considering the temperature characteristic and the DC bias characteristic of the ceramic capacitors, please determine the right capacitance. The capacitance of the capacitors changes in low and high temperature ambiances and depends on the applied bias voltages. The capacitance change (i.e. reduction) may affect the performance of the circuit which is containing the capacitors. Therefore, please examine the capacitors in the actual operational conditions to verify that they are right ones.
- (4) The common failure mode of multilayer ceramic capacitors is contingent insulation breakdown or short circuit. When the capacitors are used in a high-power circuit, they may damage the surroundings of the capacitors when failed. Therefore, the high-power circuit should have protective device/protective devices to shut down the circuit from the capacitor/capacitors. The reliability of the capacitors improves when the ambient temperatures are in the normal temperature range and the applied voltages are low.
- (5) When large high frequency ripple current crosses multilayer ceramic capacitor, the capacitor can vibrate. The phenomenon occurs as the capacitor, has natural vibration frequency due to the mechanical dimensions, resonates to the large high frequency ripple current.

To prevent the resonance, please select the capacitor or change the ripple current frequency.

For your information, we indicate the following resonance frequency to each chip size.

Size Code	Chip Size	(kHz)
NTS, NTF, NTJ, NTD		
31	3.2× 1.6	650, 1200, 1600
32	3.2× 2.5	650, 850, 1200
43	4.5× 3.2	450, 650, 1200
55	5.7× 5.0	350, 450, 850

Size Code		Chip Size	(kHz)
THC, THP	THD		
21		2.0× 1.25	900, 1500, 1800
31		3.2× 1.6	600, 1200, 1600
32	32	3.2× 2.5	600, 750, 1200
43	43	4.5× 3.2	400, 600, 1000
55	55	5.7× 5.0	300, 400, 900
76	76	7.5× 6.3	250, 350, 750
	80	10.0× 9.0	160, 200, 600
	90	20.0× 12.7	90, 160, 500
	99	25.0× 12.7	75, 160, 300

- (6) The capacitance of the capacitors depends on the ambient temperatures and bias voltages. Therefore, please examine the capacitors when they are to be used in a time-constant circuit before the use.
- (7) Consult us for devices that requires high reliability. For components which are used to the devices whose failure affects human life or causes social loss by serious damage, higher reliable designs than general purpose components are required.

2 In designing PC boards

- (1) Put the proper volume of solder (the size of fillet) on PC boards for installing surface mount capacitors, because it directly affects the installed capacitors. The design of copper pad patterns and dimensions should be set so that the proper volume of solder can be provided. The standard land dimensions are shown below.

- (2) Land width of PC boards shall not exceed the width of chip capacitors.

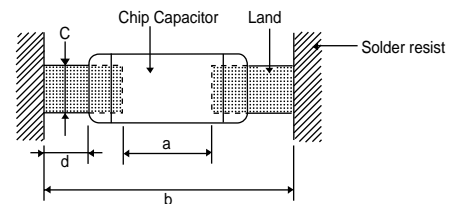

●Chip type		(mm)					
Code	Size Code	21	31	32	43	55	76
a		1.2 to 1.4	2.2 to 2.5	2.2 to 2.5	3.5 to 3.7	4.5 to 4.7	5.0 to 5.2
b		3.0 to 4.6	4.2 to 5.8	4.2 to 5.8	5.5 to 6.1	6.7 to 8.3	8.8 to 10.8
c		0.9 to 1.2	1.2 to 1.6	1.8 to 2.5	2.3 to 3.2	3.5 to 5.0	4.7 to 6.3
d		0.3 to 0.6	0.4 to 0.8	0.5 to 1.0	0.6 to 1.1	0.7 to 1.2	0.8 to 1.3

●Metal Cap type		(mm)		
Code	Size Code	43	55	76
a		2.5 to 3.5	3.5 to 4.5	5.5 to 6.5
b		5.5 to 6.1	6.5 to 7.5	8.8 to 9.8
c		2.3 to 3.2	4.0 to 5.0	5.5 to 6.5
d		0.6 to 1.1	0.5 to 1.5	0.8 to 1.8

- (3) When the multilayer ceramic capacitors are mounted on a substrate, the chips may crack when mechanical stress is put. Also, when the substrate is bent, they may also crack. Therefore, please make sure that the material and size of the substrate and the capacitor positions are right.

- (4) For a leaded capacitor, design the PC boards with the correct terminal hole space equal to the lead space of the capacitor.

3 Installation

- (1) When installing leaded capacitors in the PC boards by means of an automatic insertion machine, minimize the mechanical shock applied to the capacitors by the lead clinch unit of the machine.
- (2) When the capacitors are to be mounted on a substrate, please minimize the shock and weight to the capacitor bodies. The nozzle pressure during the mounting process should be adjusted to 1N~3N maximum in static load.
- (3) Periodically maintain and inspect installation machines.
- (4) Where an adhesive is used to pre-anchor capacitors on PC boards, use appropriate copper pad dimensions, type of adhesive, coating volume, curing temperature and time, etc. to prevent the capacitors from deteriorating.

4 Soldering

- (1) Use flux with a halogen content of less than 0.1 wt. %. Do not use strong acid flux.
- (2) Minimize a volume of flux to coat the PC boards with.
- (3) Follow the soldering conditions prescribed in the catalog or product specifications. Excessive thermal stress affects the performance of the capacitors.
- (4) Note that surface mount capacitors with the size 3.2×1.6 or smaller tend to stand up during vapor phase reflow soldering.
- (5) For reflow soldering, place surface mount capacitors on the PC boards as soon as possible after solder paste was coated.
- (6) Please be aware that thermal deformation of substrates during mounting process cause stress to the substrates. Especially, substrates which are mounting chip capacitors are to be flow soldered to solder leaded parts or solder other parts onto the substrates, please make sure that the deformation during the soldering causes no harm. In fact, the deformation may cause stress to the substrates which leads to the capacitor element cracks/insulation-layer break down/insulation resistance degradation. The effect of the stress due to the deformation depends on the material of the substrates. Therefore, please be aware of the following information.
 - a) Ceramic substrates

The stress due to the deformation of ceramic substrates is thought to be the minimum. Heat contract difference during solder hardening can be the effect to ceramic capacitors mounted on the substrates. So, please avoid forced cooling during the hardening.
 - b) Glass epoxy substrates

The stress due to the deformation and warp of glass epoxy substrates affects ceramic capacitors mounted. The stress depends on the size and material of the substrates, pattern positions and thermal gradient during soldering. Temperature difference between the both sides of the substrates may also cause the stress. When the material of the substrates, which are mounting ceramic capacitors, is FR-4 or the equivalent and other parts are to be flow soldered, the surface of the side with the capacitors shall be sufficiently preheated to 150°C or over before the flow soldering. During the soldering, the temperature difference between the side with the capacitors and the other side of the substrate should be 100°C maximum.
 - c) Metal substrates

The deformation and warp of metal substrates considerably affect ceramic capacitors mounted. Therefore, please use metal caps which can moderate the stress of the substrates.
- (7) After reflow/flow soldering, please cool the PC boards which mounted capacitors naturally in the air.
- (8) Ceramic chip capacitors are solderable by twice maximum in reflow or flow soldering. When the capacitors are to be reflow soldered and then flow soldered, there shall be no additional soldering to the capacitors. However, the capacitors having a size of 5.7×5.0 or larger should be soldered by one time only.
- (9) Due to the nature of ceramic, radical heating or cooling and partial heating may crack the ceramic capacitor element. Please have enough pre-heating process before soldering.
- (10) Ultrasonic cleaning time shall be ten minutes maximum.

When the power of ultrasonic cleaner is too high, the strength of terminations may drop. Therefore, carefully examine the cleaning conditions before use.
- (11) Adjust the amount of solder cream in order that solder fillet shall be 1/2 to 2/3 height of chips. If fillet can confirm, size of 4.5×3.2 or larger is not this limit.
- (12) When more than two chips are mounted on a common land, please separate the chips by the solder resist.
- (13) In hand soldering, please take into consideration the following items.
 1. Fully pre-heat on a heating plate whose surface temperature is 100°C to 150°C .
 2. Soldering iron power shall not exceed 30W.
 3. Soldering iron tip diameter shall not exceed 3mm.
 4. Temperature of iron tip shall be adjusted to not exceed 300°C.
 5. The soldering iron tip shall not touch ceramic body directly.
 6. After soldering, let the products to be room temperature to cool gradually.

5 Soldering profile

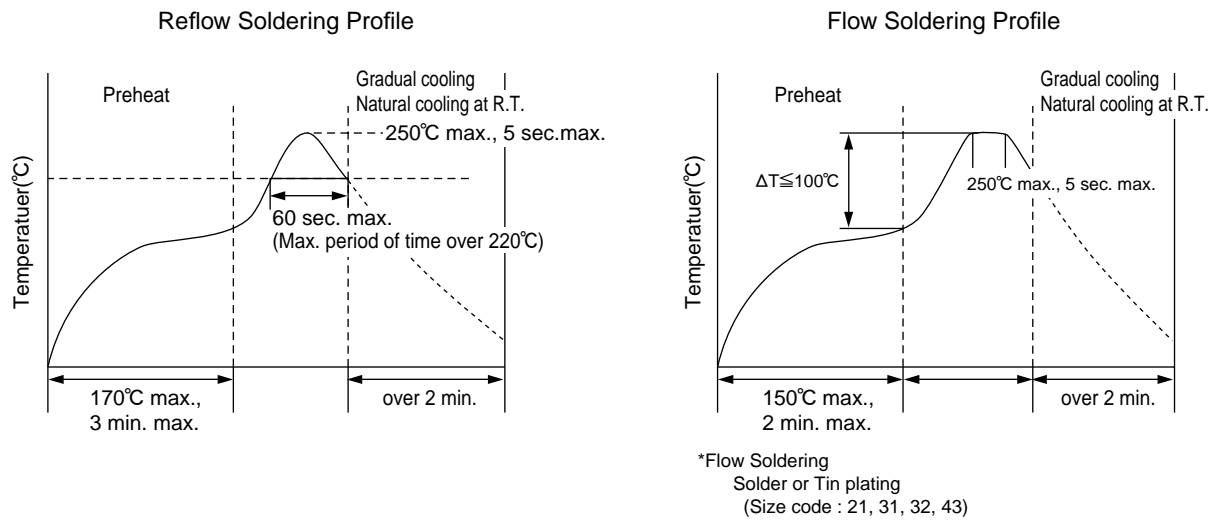

6 Cleaning

- (1) In the case that the assembly boards are washed, choose the appropriate cleaning agent for the washing purpose.
- (2) To determine the cleaning conditions, make sure by means of the actual washing equipment that the performance of the capacitors is not affected.
- (3) In the case that water-soluble flux was used, sufficiently wash the assembly boards.

7 Coating materials

- (1) When ceramic capacitors are to be resin coated or molded, please pay enough attention. Ceramic capacitors molded in resin, and please do not use it. There is fear to destroy a capacitor by stress to occur by the expansion / the shrinkage when resin stiffens. When a thermal expansion shrinkage coefficient in hardening uses big resin, coating in the resin which is soft with capacitors, please make that stress is added to capacitors small as much as possible.
- (2) Confirm that harmful resolution or formation gasses are not generated from the coating materials during the curing process or by spontaneously leaving the coated assembly boards.
- (3) If a coating material is cured at higher temperatures than the Category temperature of the capacitor, the exterior resin will deteriorate resulting in the capacitor damage.

8 Handling

- (1) When cutting off a multi-board to make individual units, curving or twisting the board may crack the capacitors. Appropriate tools should be used to cut it off.
- (2) Excessive mechanical shock to capacitors or their assembly boards may make the capacitors crack.
- (3) Use leaded capacitors without bending their lead wires as much as possible.
- (4) When ceramic capacitors are stored with no load, the capacitance reduces during the storage (named "aging characteristic"). As for the product that capacitance decreased, capacity recovers in an initial value by heat-treating it.
- (5) When the electrodes of the ceramic capacitors are made of silver, needle crystals may form on the electrodes in an ambience containing sulfur compounds.

9 Storage

- (1) Do not store and use capacitors in the following environment. Water or salt water splashes, dew wets or toxic gasses (hydrogen sulfide, sulfurous acid, chlorine, ammonium) fills, Vibration or mechanical shock exceeding the limits prescribed in the catalog or product specifications.
- (2) Do not store capacitors in places that direct sunlight pours down or dewy places.
- (3) Avoid high temperature and humidity.
The storage conditions should be : Temperature=Lower than 40°C
Humidity=Lower than 70% RH



10 Catalogs

Specification in catalogs may be subject to change without notice. Performance test data in the catalogs show typical values, which are not assured in the catalogs.

11 Regarding compliance for EU REACH Regulation

According to the content of REACH handbook (Guidance on requirements for substances in articles which is published on May 2008), our electronic components are "articles without any intended release". Therefore they are not applicable for "Registration" for EU REACH Regulation Article 7 (1).

Reference: Electrolytic Condenser Investigation Society

"Study of REACH Regulation in EU about Electrolytic Capacitor" (publicized on 13 March 2008)

For the details, refer to Guideline of notabilia for fixed multilayer ceramic capacitors for use in electronic equipment, EIAJ RCR-2335 issued by Electronic Industries Association of Japan.

Part Numbering System

The current parts numbering system is changed to new system for global coding.
Your cooperation will be very much appreciated.

◆Multilayer Ceramic Capacitors

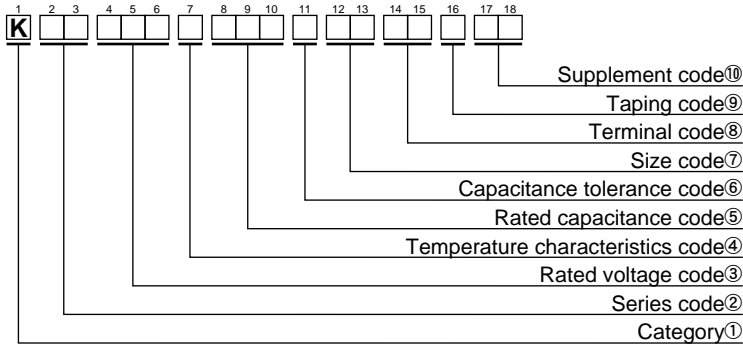

①Category

Code	Details
K	Multilayer Ceramic Capacitors

②Series code

Code	Series
TS	NTS
TF	NTF
TD	NTD
TJ	NTJ
HC	THC
MC	TMC
HD	THD
HP	THP
MP	TMP

③Rated voltage code

Significant digit (two columns) + index (one column) unit : V_{dc}

Code	Rated voltage
250	25V _{dc}
500	50V _{dc}
101	100V _{dc}
201	200V _{dc}
251	250V _{dc}

④Temperature characteristics code

Code	Temp. character	Temp. Range	ΔC/C
E	E	-25 to 85°C	-55 to 20%
B	X7R	-55 to 125°C	±15%

⑤Rated capacitance code

Unit of capacitance with (pF), and a sign of capacitance expresses it in 3 characters.
significant digit (two columns) + index (one column) unit : pF
(Example 1μF=1000000pF)

⑥Capacitance tolerance code

Code	Tolerance
K	±10%
M	±20%
Z	-20 to +80%

⑦Size code

Type : Chip

Code	Dimensions (L×W)
21	2.0×1.25
31	3.2×1.6
32	3.2×2.5
43	4.5×3.2
55	5.7×5.0
76	7.5×6.3

Type : Radial Lead

Code	Dimensions (L×W)
32	5.0×6.5(6.0)
43	6.5×7.0(6.5, 7.5)
55	7.5(8.0)×9.0
76	10.0×11.5
80	13.5×15.0
90	22.5×20.0
99	28.5×20.0

Type : Metal Cap

Code	Dimensions (L×W)
43	4.8×3.5
55	6.0×5.0 (5.3)
76	7.8×6.6

⑧Terminal code

Type : Chip

Code	Terminal
N0	Tin plating
NL	Tin plating Excellent temp. cycle Bending : 1mm
NH	Tin plating Excellent temp. cycle Bending : 2mm
R0	Silver

Type : Radial Lead

Code	Terminal
A0	Straight Lead
B0	Crimped Lead
C0	Straight Lead (copper wire)

Type : Metal Cap

Code	Terminal				
	Series	Elements	Note	Plating	RoHS
AF	NTJ	1	Size code 55	Tin	Compliant
BF	NTJ	2	Size code 55	Tin	Compliant
5A	THP	2	Size code 43 and 55	Silver	Compliant
5B	THP	2	Size code 76	Silver	Compliant
5E	TMP	2	Spring mechanism	Silver	Compliant

⑨Taping code

Code	Taping
T	Taping
B	In pieces

⑩Supplement code

Code	Supplement
00	Standard

◆CHIP TYPE TAPING SPECIFICATION

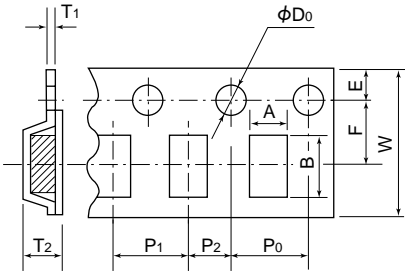

Type	Size Code	Dimensions (mm)										
		A*	B*	W ±0.3	F ±0.05	E ±0.1	P ₁ ±0.1	P ₂ ±0.05	P ₀ ±0.1	φD ±0.1	T ₁ max.	T ₂ max.
Chip type	21	1.45	2.5	8.0	3.5	1.75	4.0	2.0	4.0	1.5	0.6	1.5
	31	1.9	3.5	8.0	3.5	1.75	4.0	2.0	4.0	1.5	0.6	1.5
	32	2.8	3.5	8.0	3.5	1.75	4.0	2.0	4.0	1.5	0.6	2.5
	43	3.65	4.95	12.0	5.5	1.75	8.0	2.0	4.0	1.5	0.6	2.8
	55	5.5	6.25	12.0	5.5	1.75	8.0	2.0	4.0	1.5	0.6	3.5
Metal cap type	43	3.8	5.2	12.0	5.5	1.75	8.0	2.0	4.0	1.5	0.6	6.0
	55	5.3	6.4	16.0	7.5	1.75	8.0	2.0	4.0	1.5	0.6	6.0
	76	6.9	8.2	16.0	7.5	1.75	12.0	2.0	4.0	1.5	0.6	7.5

*Reference

●REEL SPECIFICATIONS

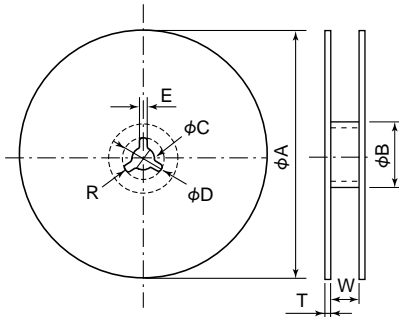

Size Code	Dimensions (mm)				
	NTS, NTF, THC, TMC			NTJ, THP, TMP	
	21, 31, 32	43, 55	76	43	55, 76
φA	178±2	178±2	178±2	178±2	382±2
φB	50min.	50min.	50min.	50min.	80min.
φC	13±0.5	13±0.5	13±0.5	13±0.5	13±0.5
φD	21±0.8	21±0.8	21±0.8	21±0.8	21±0.8
E	2±0.5	2±0.5	2±0.5	2±0.5	2±0.5
W	9±0.5	13±0.5	17±0.5	13±0.5	17±0.5
T	1±0.5	1±0.5	1±0.5	1±0.5	2±0.5
R	1.0	1.0	1.0	1.0	1.0

NTS, NTF, THC, TMC Series quantity per reel (pcs. / reel)

Size Code	21	31	32	43	55	76
Quantity	3,000	3,000	1,600	800	800	500

NTJ, THP, TMP Series quantity per reel (pcs. / reel)

Size Code	43	55	76
Quantity	500	2,000	1,200

Note : Above quantity may vary for rating of capacitor.

Note : Above quantity may vary for rating of capacitor.

◆RADIAL LEAD TYPE TAPING SPECIFICATION

●THD, NTD Series

Available for 32, 43, 55, 76 sizes. Ammo Packaging.

Size Code	Dimensions H (mm)		Quantity per Packing (pcs.)
	Straight lead	Crimped lead	
32	23max.	25max.	2,000
43	24max.	26max.	
55	26max.	28max.	
76	29max.	30max.	1,500

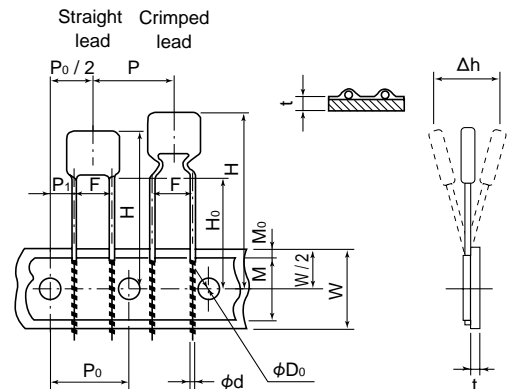

Code	P	P ₀	P ₁	P ₀ / 2	F	W	W / 2	M	M ₀	H ₀	φD ₀	φd	t	Δh
Dimensions (mm)	12.7	12.7	3.85	6.35	5.0	18.0	9.0	13.0	1.5	16.0	4.0	0.5	0.6	0
	±1	±0.3	±0.7	±1.3	+0.8 -0.2	+1.0 -0.5	±0.5	±1	±1.5	min.	±0.2	±0.05	±0.2	±2

MINIMUM ORDER QUANTITY

Please order by units of minimum order quantity.

◆Chip

Size code	Quantity (pcs)
21	300
31	300
32	200
43	100
55	50
76	50

◆Radial Lead

Size code	Quantity (pcs)
32	100
43	100
55	100
76	50
80	10
90	10
99	10

◆Metal Cap

Size code	Quantity (pcs)
All size	100

Upgrade!

NTS Series / **NTF** Series

Upgrade!

Temperature cycle : 1000 cycles



◆FEATURES

1. Large capacitance by small size.
2. Excellent noise absorption.
3. High permissible ripple current capability.
4. NTF: Temperature cycle : 1,000 cycles.

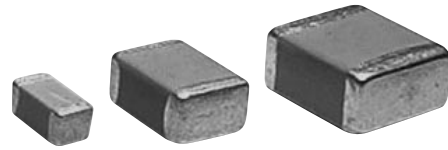

◆APPLICATIONS

1. Smoothing circuit of DC-DC converters.
2. On-board power supplies.
3. Voltage regulators for computers.
3. Noise suppressor for various kinds of equipments.
4. High reliability equipments.

◆CONSTRUCTION

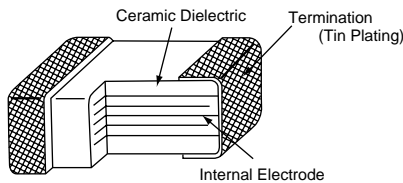

◆RATINGS

1. Category Temperature Range	-55 to +125°C
2. Rated Voltage Range	25, 50, 100, 250V _{dc}
3. Rated Capacitance Range	0.033 to 33μF
4. Rated Capacitance Tolerance	K (±10%), M (±20%)
5. Temperature Characteristics	X7R
6. Rated Ripple Current	See No.5 on the following table

◆SPECIFICATIONS

No.	Items	Specification	Test Condition												
1	Withstand Voltage	No abnormality.	250% of rated voltage shall be applied for 5 seconds. (Only 250V _{dc} product : 475V)												
2	Insulation Resistance	100/C _R (MΩ) or 4000(MΩ) whichever is less.	Rated voltage shall be applied for 60±5 seconds at temperature 25±2°C.												
3	Rated Capacitance	Within specified tolerance.	<table border="1"> <tr> <td></td> <td>C_R≤10μF</td> <td>C_R>10μF</td> </tr> <tr> <td>Temperature</td> <td colspan="2">25±2°C</td> </tr> <tr> <td>Frequency</td> <td>1±0.1kHz</td> <td>120±12Hz</td> </tr> <tr> <td>Voltage</td> <td>1±0.2V_{rms}</td> <td>0.5±0.2V_{rms}</td> </tr> </table>		C _R ≤10μF	C _R >10μF	Temperature	25±2°C		Frequency	1±0.1kHz	120±12Hz	Voltage	1±0.2V _{rms}	0.5±0.2V _{rms}
	C _R ≤10μF	C _R >10μF													
Temperature	25±2°C														
Frequency	1±0.1kHz	120±12Hz													
Voltage	1±0.2V _{rms}	0.5±0.2V _{rms}													
4	Dissipation Factor	5.0% maximum.													
5	Rated Ripple Current	<table border="1"> <tr> <td>Size code</td> <td>31</td> <td>32</td> <td>43</td> <td>55</td> </tr> <tr> <td>Arms</td> <td>0.3</td> <td>0.5</td> <td>1.0</td> <td>2.0</td> </tr> </table>	Size code	31	32	43	55	Arms	0.3	0.5	1.0	2.0	10kHz~1MHz (sine curve) Ripple voltage V _p shall be less than the rated voltage.		
Size code	31	32	43	55											
Arms	0.3	0.5	1.0	2.0											

◆SPECIFICATIONS

No.	Items	Specification	Test Condition															
6	Adhesion	No visible damage.	<p>Substrate 5N (0.51kgf) for 10±1 seconds Capacitor</p>															
7	Bend strength of the face plating	Appearance : No visible damage. $\Delta C/C : \pm 15\%$	<p>The substrate shall be bend at a rate of 1mm/s for 5 seconds.</p> <p>Press Press bar Substrate Capacitor Support Bending capability*</p> <p>*Bending capability NTS : 1mm NTF : 1mm or 2mm</p>															
8	Solderability	Min. 75% of surface of the termination shall be covered with new solder	<table border="1"> <thead> <tr> <th>Solder</th> <th>Pb Free</th> <th>Eutectic</th> </tr> </thead> <tbody> <tr> <td>Solder Temperature</td> <td>245±5°C</td> <td>235±5°C</td> </tr> <tr> <td>Dipping Time</td> <td colspan="2">2±0.5sec.</td> </tr> </tbody> </table>	Solder	Pb Free	Eutectic	Solder Temperature	245±5°C	235±5°C	Dipping Time	2±0.5sec.							
Solder	Pb Free	Eutectic																
Solder Temperature	245±5°C	235±5°C																
Dipping Time	2±0.5sec.																	
9	Resistance to Soldering Heat	Appearance : No visible damage. $\Delta C/C : \pm 15\%$ D.F. : To meet the initial specification. I.R. : To meet the initial specification.	<p>Solder Temperature : 260±5°C Dipping Time : 2±0.5 seconds</p>															
10	Temperature Cycle	Appearance : No visible damage. $\Delta C/C : \pm 15\%$ D.F. : To meet the initial specification. I.R. : To meet the initial specification.	<table border="1"> <thead> <tr> <th>Step</th> <th>Temperature (°C)</th> <th>(min.)</th> </tr> </thead> <tbody> <tr> <td>1</td> <td>Min. Category temperature ±3</td> <td>30±3</td> </tr> <tr> <td>2</td> <td>Room temperature</td> <td>3 max.</td> </tr> <tr> <td>3</td> <td>Max. Category temperature ±3</td> <td>30±3</td> </tr> <tr> <td>4</td> <td>Room temperature</td> <td>3 max.</td> </tr> </tbody> </table> <p>For above temperature cycle. NTS : For 5 cycles NTF : For 1000 cycles</p>	Step	Temperature (°C)	(min.)	1	Min. Category temperature ±3	30±3	2	Room temperature	3 max.	3	Max. Category temperature ±3	30±3	4	Room temperature	3 max.
Step	Temperature (°C)	(min.)																
1	Min. Category temperature ±3	30±3																
2	Room temperature	3 max.																
3	Max. Category temperature ±3	30±3																
4	Room temperature	3 max.																
11	Humidity Load Life	Appearance : No abnormality. $\Delta C/C : \pm 15\%$ D.F. : 10% maximum I.R. : 25/C _R (MΩ) or 1000(MΩ) whichever is less.	<p>Temperature : 40±2°C Humidity : 90 to 95%RH Voltage : Rated voltage Time : 500±²⁴₀hours</p>															
12	Endurance	Appearance : No abnormality. $\Delta C/C : \pm 15\%$ D.F. : 10% maximum I.R. : 50/C _R (MΩ) or 1000(MΩ) whichever is less.	<p>Temperature : 125±3°C Voltage : Rated voltage Time : 1000±⁴⁸₀hours</p>															

*C_R : Rated Capacitance(μF)

◆STANDARD RATINGS

Rated voltage (Vdc)	Rated Capacitance (μF)	Dimensions(mm)				Maximum ripple current (Arms)	Part Number	Previous Part Number (Just for your reference)
		L	W	Tmax.	a			
25	1.0	3.2±0.2	1.6±0.2	1.8	0.5±0.3	0.3	KTS250B105M31N0T00	NTS30X7R1E105MT
	1.5						KTS250B155M31N0T00	NTS30X7R1E155MT
	2.2						KTS250B225M31N0T00	NTS30X7R1E225MT
	3.3	3.2±0.4	2.5±0.3	2.6	0.6±0.3	0.5	KTS250B335M32N0T00	NTS40X7R1E335MT
	4.7						KTS250B475M32N0T00	NTS40X7R1E475MT
	6.8						KTS250B685M32N0T00	NTS40X7R1E685MT
	10	4.5±0.4	3.2±0.4	2.8	0.6±0.3	1.0	KTS250B106M43N0T00	NTS50X7R1E106MT
	15						KTS250B156M43N0T00	NTS50X7R1E156MT
	22						5.7±0.4	5.0±0.4
	33	3.0	KTS250B336M55N0T00	NTS60X7R1E336MT				
50	0.33	3.2±0.2	1.6±0.2	1.8	0.5±0.3	0.3	KTS500B334M31N0T00	NTS30X7R1H334MT
	0.47						KTS500B474M31N0T00	NTS30X7R1H474MT
	0.68						KTS500B684M31N0T00	NTS30X7R1H684MT
	1.0						KTS500B105M31N0T00	NTS30X7R1H105MT
	1.5	3.2±0.4	2.5±0.3	2.6	0.6±0.3	0.5	KTS500B155M32N0T00	NTS40X7R1H155MT
	2.2						KTS500B225M32N0T00	NTS40X7R1H225MT
	3.3						KTS500B335M32N0T00	NTS40X7R1H335MT
	4.7	4.5±0.4	3.2±0.4	2.8	0.6±0.3	1.0	KTS500B475M43N0T00	NTS50X7R1H475MT
	6.8						KTS500B685M43N0T00	NTS50X7R1H685MT
	10						KTS500B106M55N0T00	NTS60X7R1H106MT
15	5.7±0.4	5.0±0.4	2.8	0.8±0.5	2.0	KTS500B156M55N0T00	NTS60X7R1H156MT	
33						KTS101B104M31N0T00	NTS30X7R2A104MT	
100	0.1	3.2±0.2	1.6±0.2	1.8	0.5±0.3	0.3	KTS101B154M31N0T00	NTS30X7R2A154MT
	0.15						KTS101B224M31N0T00	NTS30X7R2A224MT
	0.22						KTS101B334M31N0T00	NTS30X7R2A334MT
	0.33						KTS101B474M31N0T00	NTS30X7R2A474MT
	0.47						KTS101B684M31N0T00	NTS30X7R2A684MT
	1.0						KTS101B105M32N0T00	NTS40X7R2A105MT
	1.5	3.2±0.4	2.5±0.3	2.6	0.6±0.3	0.5	KTS101B155M32N0T00	NTS40X7R2A155MT
	2.2						KTS101B225M32N0T00	NTS40X7R2A225MT
	3.3						KTS101B335M32N0T00	NTS40X7R2A335MT
	4.7	4.5±0.4	3.2±0.4	2.8	0.6±0.3	1.0	KTS101B475M43N0T00	NTS50X7R2A475MT
	6.8						KTS101B685M43N0T00	NTS50X7R2A685MT
	10						KTS101B106M55N0T00	NTS60X7R2A106MT
	15	5.7±0.4	5.0±0.4	2.8	0.8±0.5	2.0	KTS101B156M55N0T00	NTS60X7R2A156MT
	33						KTS101B335M43N0T00	—
	47	5.7±0.4	5.0±0.4	2.8	0.8±0.5	2.0	KTS101B475M43N0T00	—
	68						KTS101B685M43N0T00	—
	100						KTS101B104M31N0T00	—
	250	0.033	3.2±0.2	1.6±0.2	1.8	0.5±0.3	0.3	KTS251B333M31N0T00
0.047		KTS251B473M31N0T00						NTS30X7R2E473MT
0.068		KTS251B683M31N0T00						NTS30X7R2E683MT
0.1		KTS251B104M31N0T00						NTS30X7R2E104MT
0.15		3.2±0.4	2.5±0.3	2.6	0.6±0.3	0.5	KTS251B154M32N0T00	NTS40X7R2E154MT
0.22							KTS251B224M32N0T00	NTS40X7R2E224MT
0.33							KTS251B334M32N0T00	NTS40X7R2E334MT
0.47		4.5±0.4	3.2±0.4	2.8	0.6±0.3	1.0	KTS251B474M43N0T00	NTS50X7R2E474MT
0.68							KTS251B684M43N0T00	NTS50X7R2E684MT
1.0							KTS251B105M55N0T00	NTS60X7R2E105MT
1.5		5.7±0.4	5.0±0.4	2.8	0.8±0.5	2.0	KTS251B155M55N0T00	NTS60X7R2E155MT
33							KTS251B333M31N0T00	NTS30X7R2E333MT

◆PART NUMBERING SYSTEM

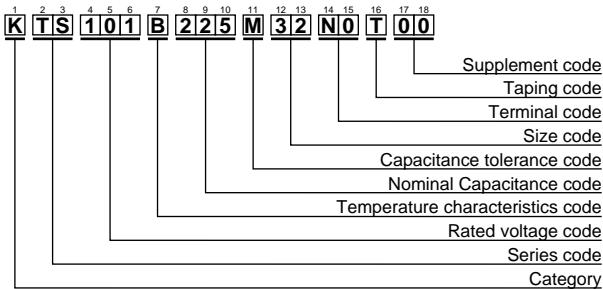

◆DIMENSIONS

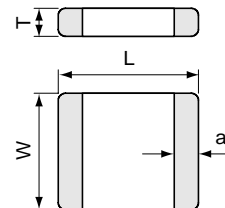

◆STANDARD RATINGS

Rated voltage (Vdc)	Rated Capacitance (μF)	Dimensions(mm)				Maximum ripple current (Arms)	Part Number
		L	W	Tmax.	a		
25	1.0	3.2±0.3	1.6±0.2	1.8	0.7±0.2	0.3	KTF250B105M31NLT00
	1.5						KTF250B155M31NLT00
	2.2						KTF250B225M31NLT00
	3.3	3.2±0.4	2.5±0.3	2.6	0.7±0.2	0.5	KTF250B335M32NHT00
	4.7						KTF250B475M32NHT00
	6.8						KTF250B685M32NHT00
	10	4.5±0.4	3.2±0.4	2.8	0.7±0.2	1.0	KTF250B106M43NHT00
	15						KTF250B156M43NHT00
	22						5.7±0.4
	33	3.0	KTF250B336M55NHT00				
50	0.33	3.2±0.3	1.6±0.2	1.8	0.7±0.2	0.3	KTF500B334M31NLT00
	0.47						KTF500B474M31NLT00
	0.68						KTF500B684M31NLT00
	1.0						KTF500B105M31NLT00
	1.5	3.2±0.4	2.5±0.3	2.6	0.7±0.2	0.5	KTF500B155M32NHT00
	2.2						KTF500B225M32NHT00
	3.3						KTF500B335M32NHT00
	4.7	4.5±0.4	3.2±0.4	2.8	0.7±0.2	1.0	KTF500B475M43NHT00
	6.8						KTF500B685M43NHT00
	10						5.7±0.4
15	KTF500B156M55NHT00						
100	0.1	3.2±0.3	1.6±0.2	1.8	0.7±0.2	0.3	KTF101B104M31NLT00
	0.15						KTF101B154M31NLT00
	0.22						KTF101B224M31NLT00
	0.33						KTF101B334M31NLT00
	0.47						KTF101B474M31NLT00
	0.68						KTF101B684M31NLT00
	1.0	3.2±0.4	2.5±0.3	2.6	0.7±0.2	0.5	KTF101B105M32NHT00
	1.5						KTF101B155M32NHT00
	2.2						KTF101B225M32NHT00
	1.5	4.5±0.4	3.2±0.4	2.8	0.7±0.2	1.0	KTF101B155M43NHT00
	2.2						KTF101B225M43NHT00
	3.3						KTF101B335M43NHT00
	4.7	5.7±0.4	5.0±0.4	2.8	1.0±0.4	2.0	KTF101B475M43NHT00
	4.7						KTF101B475M55NHT00
	6.8						KTF101B685M55NHT00
	250	0.033	3.2±0.3	1.6±0.2	1.8	0.7±0.2	0.3
0.047		KTF251B473M31NLT00					
0.068		KTF251B683M31NLT00					
0.1		3.2±0.4	2.5±0.3	2.6	0.7±0.2	0.5	KTF251B104M31NLT00
0.15							KTF251B154M32NLT00
0.22							KTF251B224M32NLT00
0.33		4.5±0.4	3.2±0.4	2.8	0.7±0.2	1.0	KTF251B334M32NLT00
0.47							KTF251B474M32NLT00
0.68							KTF251B684M32NLT00
1.0		5.7±0.4	5.0±0.4	2.8	1.0±0.4	2.0	KTF251B105M55NLT00
1.5							KTF251B155M55NLT00

◆PART NUMBERING SYSTEM

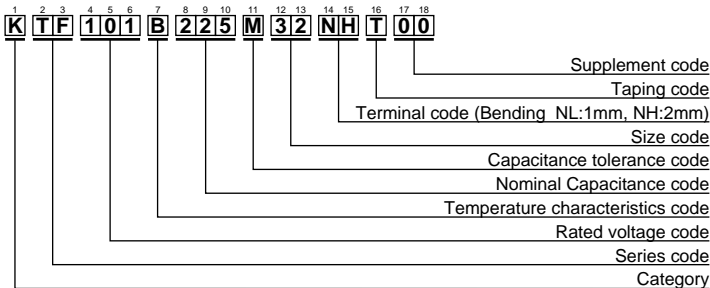

◆DIMENSIONS

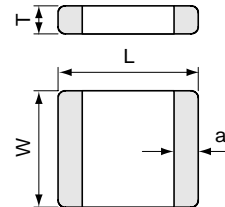

New!

NTJ Series

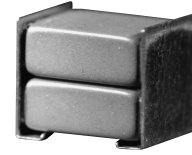

◆FEATURES

1. Small size and large capacitance, high ripple current.
2. Temperature cycle: 1,000 cycles.
3. X7R temperature characteristics.
4. Excellent noise absorption.
5. For reflow soldering use.
6. Suitable for aluminum substrate.

◆APPLICATIONS

1. Smoothing circuit of switching mode AC-DC or DC-DC converter.
2. On-board power supply.
3. Noise suppressor for various kinds of equipments.

◆CUSTOM MADE PRODUCTS

We can offer custom made one element metal cap type capacitors for request of customers. Please contact us if you have questions for details.

◆CONSTRUCTION

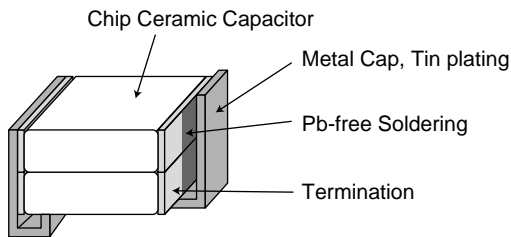

◆RATINGS

1. Category Temperature Range	-55~+125°C
2. Rated Voltage Range	25, 50, 100, 250V _{dc}
3. Rated Capacitance Range	1.5 to 47μF
4. Rated Capacitance Tolerance	M(±20%)
5. Temperature Characteristics	X7R
6. Rated Ripple Current	See No.5 on the following table

◆SPECIFICATIONS

No.	Items	Specification	Test Condition												
1	Withstand Voltage	No abnormality.	250% of rated voltage shall be applied for 5 seconds. (Only 250V _{dc} products : 475V)												
2	Insulation Resistance	100/C _R (MΩ) or 4000(MΩ) whichever is less.	Rated voltage shall be applied for 60±5 seconds at temperature 25±2°C.												
3	Rated Capacitance	Within specified tolerance.	<table border="1"> <tr> <td></td> <td>C_R≤10μF</td> <td>C_R>10μF</td> </tr> <tr> <td>Temperature</td> <td colspan="2">25±2°C</td> </tr> <tr> <td>Frequency</td> <td>1±0.1kHz</td> <td>120±12Hz</td> </tr> <tr> <td>Voltage</td> <td>1±0.2Vrms</td> <td>0.5±0.2Vrms</td> </tr> </table>		C _R ≤10μF	C _R >10μF	Temperature	25±2°C		Frequency	1±0.1kHz	120±12Hz	Voltage	1±0.2Vrms	0.5±0.2Vrms
	C _R ≤10μF	C _R >10μF													
Temperature	25±2°C														
Frequency	1±0.1kHz	120±12Hz													
Voltage	1±0.2Vrms	0.5±0.2Vrms													
4	Dissipation Factor	5.0% maximum													
5	Rated Ripple Current	<table border="1"> <tr> <td>Size</td> <td>55</td> </tr> <tr> <td>Arms</td> <td>3.0</td> </tr> </table>	Size	55	Arms	3.0	10kHz~1MHz (sine curve) Ripple voltage V _p shall be less than the rated voltage.								
Size	55														
Arms	3.0														

◆SPECIFICATIONS

No.	Items	Specification	Test Condition															
6	Temperature Cycle	Appearance : No visible damage. ΔC/C : ±15% D.F. : To meet the initial specification. I.R. : To meet the initial specification.	<table border="1"> <thead> <tr> <th>Step</th> <th>Temperature (°C)</th> <th>(min.)</th> </tr> </thead> <tbody> <tr> <td>1</td> <td>Min. Category temperature ±3</td> <td>30±3</td> </tr> <tr> <td>2</td> <td>Room temperature</td> <td>3 max.</td> </tr> <tr> <td>3</td> <td>Max. Category temperature ±3</td> <td>30±3</td> </tr> <tr> <td>4</td> <td>Room temperature</td> <td>3 max.</td> </tr> </tbody> </table> <p><Cycle> 1000 cycles</p>	Step	Temperature (°C)	(min.)	1	Min. Category temperature ±3	30±3	2	Room temperature	3 max.	3	Max. Category temperature ±3	30±3	4	Room temperature	3 max.
Step	Temperature (°C)	(min.)																
1	Min. Category temperature ±3	30±3																
2	Room temperature	3 max.																
3	Max. Category temperature ±3	30±3																
4	Room temperature	3 max.																
7	Humidity Load Life	Appearance : No abnormality. ΔC/C : ±20% D.F. : 10% max. I.R. : 25/C _R (MΩ) or 1000(MΩ) whichever is less.	Temperature : 40±2°C Humidity : 90 to 95%RH Voltage : Rated voltage Time : 500± ²⁴ ₀ hours															
8	Endurance	Appearance : No abnormality. ΔC/C : ±20% D.F. : 10% max. I.R. : 50/C _R (MΩ) or 1000(MΩ) whichever is less.	Temperature : 125±3°C Voltage : Rated voltage Time : 1000± ⁴⁸ ₀ hours															

*C_R : Rated Capacitance(μF)

◆Note of mountig for NTJ series.

1. The gap of capacitor and a substrate shall be the mounting face.
2. To prevent degradation of temperature cycling capability, if need to be careful about amount of solder that would not go into the inner side of terminations.

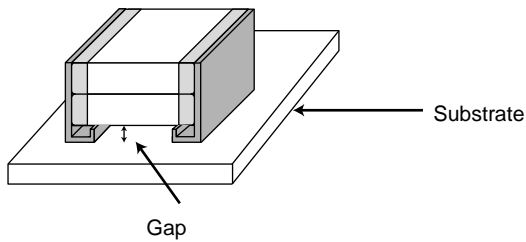

◆STANDARD RATINGS

Rated voltage (Vdc)	Rated Capacitance (μ F)	Dimensions(mm)				Maximum ripple current (Arms)	Part Number
		L	W	Tmax.	a		
25	33	6.0 \pm 0.4	5.3 \pm 0.4	5.5	1.3 \pm 0.3	3.0	KTJ250B336M55BFT00
	47						KTJ250B476M55BFT00
50	15	6.0 \pm 0.4	5.3 \pm 0.4	5.5	1.3 \pm 0.3	3.0	KTJ500B156M55BFT00
	22						KTJ500B226M55BFT00
100	6.8	6.0 \pm 0.4	5.3 \pm 0.4	5.5	1.3 \pm 0.3	3.0	KTJ101B685M55BFT00
	10						KTJ101B106M55BFT00
250	1.5	6.0 \pm 0.4	5.3 \pm 0.4	5.5	1.3 \pm 0.3	3.0	KTJ251B155M55BFT00
	2.2						KTJ251B225M55BFT00

◆PART NUMBERING SYSTEM

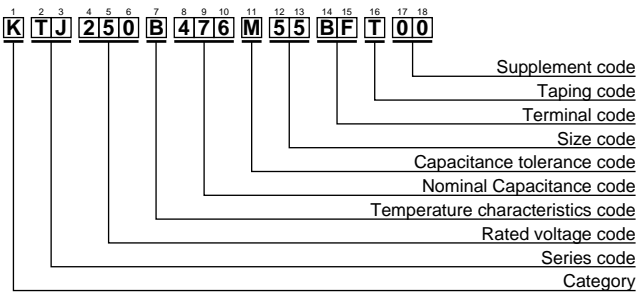

◆DIMENSIONS

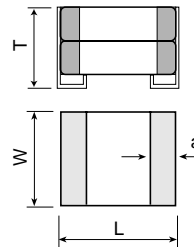



DIPPED RADIAL LEAD MULTILAYER CERAMIC CAPACITORS

Upgrade!

NTD Series

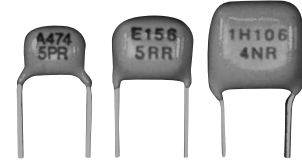

◆FEATURES

1. Small in size and wide capacitance range.
Max. 33 μ F is available.
2. Temperature characteristic is X7R in EIA code.
3. Superior humidity characteristic and long life.
4. Excellent high frequency characteristic due to low ESR.
5. High rated ripple current.
6. 250V_{dc} items are available.
7. Resin(UL94 V-0) used for coating.
8. Pb-free design(also ceramic dielectric)

◆APPLICATIONS

1. Smoothing circuit of switching mode AC-DC or DC-DC converter.
2. Noise suppressor for various kinds of equipments.
3. By-pass or decoupling circuits.
4. Automotive equipments.

◆CONSTRUCTION

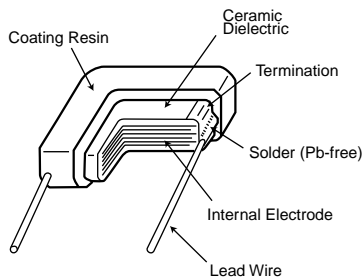

◆RATINGS

1. Category Temperature Range	-55 to +125°C
2. Rated Voltage Range	25, 50, 100, 250 V _{dc}
3. Rated Capacitance Range	0.1 to 33 μ F
4. Rated Capacitance Tolerance	M(\pm 20%)
5. Temperature Characteristics	X7R
6. Rated Ripple Current	See No.5 on the following table

◆SPECIFICATIONS

No.	Items	Specification	Test Condition						
1	Withstand Voltage	Between Terminals	250% of rated voltage shall be applied for 5 seconds. (Only 250V _{dc} products : 475V)						
		Terminals to Coating Resin							
2	Insulation Resistance	100/C _R (M Ω) or 4000(M Ω) whichever is less.	Rated voltage shall be applied for 60 \pm 5 seconds at temperature 25 \pm 2°C.						
3	Rated Capacitance	Within specified tolerance.	<table border="1"> <tr> <td></td> <td>C_R\leq10μF</td> <td>C_R>10μF</td> </tr> <tr> <td>Temperature</td> <td colspan="2">25\pm2°C</td> </tr> </table>		C _R \leq 10 μ F	C _R >10 μ F	Temperature	25 \pm 2°C	
				C _R \leq 10 μ F	C _R >10 μ F				
Temperature	25 \pm 2°C								
4	Dissipation Factor	5.0% maximum.	<table border="1"> <tr> <td>Frequency</td> <td>1\pm0.1kHz</td> <td>120\pm12Hz</td> </tr> <tr> <td>Voltage</td> <td>1\pm0.2V_{rms}</td> <td>0.5\pm0.2V_{rms}</td> </tr> </table>	Frequency	1 \pm 0.1kHz	120 \pm 12Hz	Voltage	1 \pm 0.2V _{rms}	0.5 \pm 0.2V _{rms}
			Frequency	1 \pm 0.1kHz	120 \pm 12Hz				
Voltage	1 \pm 0.2V _{rms}	0.5 \pm 0.2V _{rms}							



DIPPED RADIAL LEAD MULTILAYER CERAMIC CAPACITORS

Upgrade!

NTD Series

◆SPECIFICATIONS

No.	Items	Specification	Test Condition															
5	Rated Ripple Current	Size code	32 43 55															
		Arms	0.3 0.8 1.0															
			10kHz to 1MHz (sine curve) Ripple voltage V_p shall be less than the rated voltage.															
6	Robustness of Terminations	No visible damage.	The force applied shall be :															
	Tension		<table border="1"> <thead> <tr> <th>Lead ϕ (mm)</th> <th>Tensile(N)</th> <th>(sec.)</th> </tr> </thead> <tbody> <tr> <td>0.5 max.</td> <td>5</td> <td>10\pm1</td> </tr> </tbody> </table>	Lead ϕ (mm)	Tensile(N)	(sec.)	0.5 max.	5	10 \pm 1									
Lead ϕ (mm)	Tensile(N)	(sec.)																
0.5 max.	5	10 \pm 1																
			<table border="1"> <thead> <tr> <th>Lead ϕ (mm)</th> <th>Bending(N)</th> <th>(kg)</th> </tr> </thead> <tbody> <tr> <td>0.5 max.</td> <td>2.5</td> <td>0.25</td> </tr> </tbody> </table>	Lead ϕ (mm)	Bending(N)	(kg)	0.5 max.	2.5	0.25									
Lead ϕ (mm)	Bending(N)	(kg)																
0.5 max.	2.5	0.25																
			Time : 2times.															
7	Vibration	Appearance : No abnormality.	Amplitude : 1.5mm															
		Capacitance : To meet the initial specification.	Frequency range : 10-55-10Hz (1 min)															
			Direction and time : 2 hours each to X, Y, Z axis. Total 6 hours.															
8	Solderability	Min. 75% of surface of the termination shall be covered with new solder.	<table border="1"> <thead> <tr> <th>Solder</th> <th>Pb Free</th> <th>Eutectic</th> </tr> </thead> <tbody> <tr> <td>Solder Temperature</td> <td>245\pm5$^{\circ}$C</td> <td>235\pm5$^{\circ}$C</td> </tr> <tr> <td>Dipping Time</td> <td colspan="2">2\pm0.5sec.</td> </tr> </tbody> </table>	Solder	Pb Free	Eutectic	Solder Temperature	245 \pm 5 $^{\circ}$ C	235 \pm 5 $^{\circ}$ C	Dipping Time	2 \pm 0.5sec.							
			Solder	Pb Free	Eutectic													
Solder Temperature	245 \pm 5 $^{\circ}$ C	235 \pm 5 $^{\circ}$ C																
Dipping Time	2 \pm 0.5sec.																	
9	Resistance to Soldering Heat	Appearance : No abnormality. $\Delta C/C$: $\pm 15\%$ D.F. : Satisfy the initial spec.	Solder Temperature : 350 \pm 10 $^{\circ}$ C Dipping Time : 3 \pm 0.5 sec. Depth : 1.5 to 2mm															
10	Temperature Cycle	Appearance : No abnormality. $\Delta C/C$: $\pm 15\%$ D.F. : To meet the initial specification I.R. : To meet the initial specification	<table border="1"> <thead> <tr> <th>Step</th> <th>Temperature ($^{\circ}$C)</th> <th>(min.)</th> </tr> </thead> <tbody> <tr> <td>1</td> <td>Min. Category temperature ± 3</td> <td>30± 3</td> </tr> <tr> <td>2</td> <td>Room temperature</td> <td>3 max.</td> </tr> <tr> <td>3</td> <td>Max. Category temperature ± 3</td> <td>30± 3</td> </tr> <tr> <td>4</td> <td>Room temperature</td> <td>3 max.</td> </tr> </tbody> </table>	Step	Temperature ($^{\circ}$ C)	(min.)	1	Min. Category temperature ± 3	30 ± 3	2	Room temperature	3 max.	3	Max. Category temperature ± 3	30 ± 3	4	Room temperature	3 max.
			Step	Temperature ($^{\circ}$ C)	(min.)													
1	Min. Category temperature ± 3	30 ± 3																
2	Room temperature	3 max.																
3	Max. Category temperature ± 3	30 ± 3																
4	Room temperature	3 max.																
			For 5 cycles for above temperature cycle.															
11	Humidity Load Life	Appearance : No abnormality. $\Delta C/C$: $\pm 20\%$ D.F. : 10% maximum I.R. : 25/ C_R (M Ω) or 1000(M Ω) whichever is less.	Temperature : 40 $\pm 2^{\circ}$ C Humidity : 90 to 95%RH Voltage : Rated voltage Time : 500 $\pm 24_0$ hours															
12	Endurance	Appearance : No abnormality. $\Delta C/C$: $\pm 20\%$ D.F. : 10% maximum I.R. : 50/ C_R (M Ω) or 1000(M Ω) whichever is less.	Temperature : 125 $\pm 3^{\circ}$ C Voltage : Rated voltage Time : 1000 $\pm 48_0$ hours															

* C_R : Rated Capacitance(μ F)

◆STANDARD RATINGS

Rated voltage (Vdc)	Rated Capacitance (μF)	Dimensions(mm)					Maximum ripple current (Arms)	Part Number
		Lmax.	Wmax.	Tmax.	F±0.8	φ±0.05		
25	3.3	5.0	6.0	3.5	5.0	0.5	0.3	KTD250B335M32A0T00
	4.7							KTD250B475M32A0T00
	6.8							KTD250B685M43A0T00
	10	6.5	6.5	4.0	5.0	0.5	0.8	KTD250B106M43A0T00
	15							KTD250B156M43A0T00
	15							KTD250B156M55A0T00
	22	7.5	9.0	4.5	5.0	0.5	1.0	KTD250B226M55A0T00
	33							KTD250B336M55A0T00
50	1.0	5.0	6.0	3.5	5.0	0.5	0.3	KTD500B105M32A0T00
	1.5							KTD500B155M32A0T00
	2.2							KTD500B225M32A0T00
	3.3							KTD500B335M32A0T00
	4.7	6.5	6.5	4.0	5.0	0.5	0.8	KTD500B475M43A0T00
	6.8							KTD500B685M43A0T00
	10							KTD500B106M55A0T00
	15	7.5	9.0	4.5	5.0	0.5	1.0	KTD500B156M55A0T00
100	0.33	5.0	6.0	3.5	5.0	0.5	0.3	KTD101B334M32A0T00
	0.47							KTD101B474M32A0T00
	0.68							KTD101B684M32A0T00
	1							KTD101B105M32A0T00
	1.5							KTD101B155M32A0T00
	2.2							KTD101B225M32A0T00
	1.5	6.5	6.5	4.0	5.0	0.5	0.8	KTD101B155M43A0T00
	2.2							KTD101B225M43A0T00
	3.3							KTD101B335M43A0T00
	4.7							KTD101B475M43A0T00
	3.3							KTD101B335M55A0T00
	4.7							KTD101B475M55A0T00
	6.8	7.5	9.0	4.5	5.0	0.5	1.0	KTD101B685M55A0T00
				4.7				KTD101B475M55A0T00
250	0.1	5.0	6.0	3.5	5.0	0.5	0.3	KTD251B104M32A0T00
	0.15							KTD251B154M32A0T00
	0.22							KTD251B224M32A0T00
	0.33							KTD251B334M32A0T00
	0.47	6.5	6.5	4.0	5.0	0.5	0.8	KTD251B474M43A0T00
	0.68							KTD251B684M43A0T00
	1							KTD251B105M55A0T00
	1.5							KTD251B155M55A0T00

◆PART NUMBERING SYSTEM

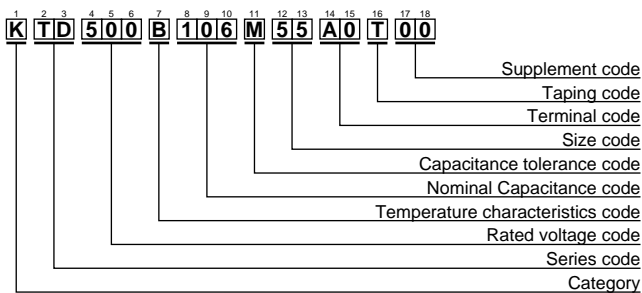

◆DIMENSIONS

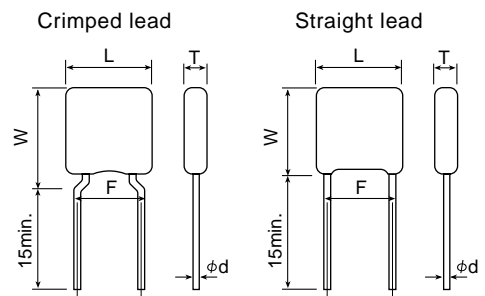



MULTILAYER CERAMIC CHIP CAPACITORS

THC Series / TMC Series (High Reliability)

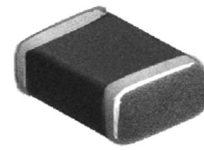

◆FEATURES

1. Small size and large capacitance, high ripple current.
2. Temperature characteristic is Y5U in EIA code.
3. Superior humidity characteristic and long life.
4. Excellent noise absorption.

◆APPLICATIONS

1. Smoothing circuit of small size DC-DC converter.
2. On-board power supply.
3. Noise suppressor for various kinds of equipments.
4. By-pass or decoupling circuits.

◆CONSTRUCTION

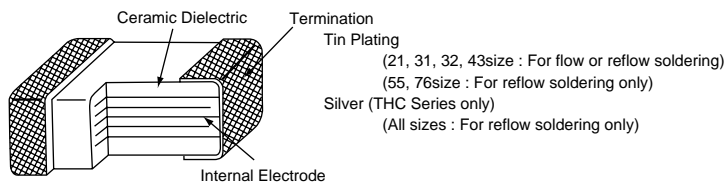

◆RATINGS

1. Category Temperature Range	-55 to +125°C
2. Rated Voltage Range	25, 50, 100, 200V _{dc}
3. Rated Capacitance Range	0.047 to 47μF
4. Rated Capacitance Tolerance	M (±20%) , Z (±20%)
5. Temperature Characteristics	E (JIS) ≒ Y5U (EIA)
6. Rated Ripple Current	See No.5 on the following table

◆SPECIFICATIONS

No.	Items	Specification	Test Condition														
1	Withstand Voltage	No abnormality.	250% of rated voltage shall be applied for 5 seconds.														
2	Insulation Resistance	1000/C _R (MΩ) or 10000(MΩ) whichever is less.	Rated voltage shall be applied for 60±5 seconds at temperature 20±2°C.														
3	Rated Capacitance	Within specified tolerance.	Temperature : 20±2°C Frequency : 1±0.1kHz Voltage : 1±0.2V _{rms}														
4	Dissipation Factor	5.0% maximum.	Temperature : 20±2°C Frequency : 1±0.1kHz Voltage : 1±0.2V _{rms}														
5	Rated Ripple Current	<table border="1"> <tr> <td>Size code</td> <td>21</td> <td>31</td> <td>32</td> <td>43</td> <td>55</td> <td>76</td> </tr> <tr> <td>Arms</td> <td>0.2</td> <td>0.3</td> <td>0.5</td> <td>1.0</td> <td>2.0</td> <td>3.0</td> </tr> </table>	Size code	21	31	32	43	55	76	Arms	0.2	0.3	0.5	1.0	2.0	3.0	10kHz~1MHz (sine curve) Ripple voltage V _p shall be less than the rated voltage.
Size code	21	31	32	43	55	76											
Arms	0.2	0.3	0.5	1.0	2.0	3.0											

◆SPECIFICATIONS

No.	Items	Specification	Test Condition															
6	Adhesion	No visible damage.	<p>Substrate 5N (0.51kgf) for 10±1 seconds Capacitor</p>															
7	Bend strength of the face plating	Appearance : No visible damage. $\Delta C/C : \pm 15\%$	<p>The substrate shall be bend by 1mm at a rate of 1mm/s for 5 seconds.</p> <p>Press Press bar Capacitor Substrate 1.0mm Support 45±2mm 45±2mm</p>															
8	Solderability	Min. 75% of surface of the termination shall be covered with new solder	<table border="1"> <thead> <tr> <th>Solder</th> <th>Pb Free</th> <th>Eutectic</th> </tr> </thead> <tbody> <tr> <td>Solder Temperature</td> <td>245±5°C</td> <td>235±5°C</td> </tr> <tr> <td>Dipping Time</td> <td colspan="2">2±0.5sec.</td> </tr> </tbody> </table>	Solder	Pb Free	Eutectic	Solder Temperature	245±5°C	235±5°C	Dipping Time	2±0.5sec.							
Solder	Pb Free	Eutectic																
Solder Temperature	245±5°C	235±5°C																
Dipping Time	2±0.5sec.																	
9	Resistance to Soldering Heat	Appearance : No visible damage. $\Delta C/C : \pm 15\%$ D.F. : To meet the initial specification. I.R. : To meet the initial specification.	<p>Solder Temperature : 260±5°C Dipping Time : 2±0.5 seconds</p>															
10	Temperature Cycle	Appearance : No visible damage. $\Delta C/C : \pm 15\%$ D.F. : To meet the initial specification. I.R. : To meet the initial specification.	<table border="1"> <thead> <tr> <th>Step</th> <th>Temperature (°C)</th> <th>(min.)</th> </tr> </thead> <tbody> <tr> <td>1</td> <td>Min. Category temperature ±3</td> <td>30±3</td> </tr> <tr> <td>2</td> <td>Room temperature</td> <td>3 max.</td> </tr> <tr> <td>3</td> <td>Max. Category temperature ±3</td> <td>30±3</td> </tr> <tr> <td>4</td> <td>Room temperature</td> <td>3 max.</td> </tr> </tbody> </table> <p><Cycle> THC series : 5 cycles TMC series : 100 cycles</p>	Step	Temperature (°C)	(min.)	1	Min. Category temperature ±3	30±3	2	Room temperature	3 max.	3	Max. Category temperature ±3	30±3	4	Room temperature	3 max.
Step	Temperature (°C)	(min.)																
1	Min. Category temperature ±3	30±3																
2	Room temperature	3 max.																
3	Max. Category temperature ±3	30±3																
4	Room temperature	3 max.																
11	Humidity Load Life	Appearance : No abnormality. $\Delta C/C : \pm 20\%$ D.F. : 7% maximum I.R. : 50/C _R (MΩ) or 1000(MΩ) whichever is less.	<p>Temperature : 40±2°C Humidity : 90 to 95%RH Voltage : Rated voltage Time : 500±²⁴₀hours</p>															
12	Endurance	Appearance : No abnormality. $\Delta C/C : \pm 20\%$ D.F. : 7% maximum I.R. : 100/C _R (MΩ) or 1000(MΩ) whichever is less.	<p>Temperature : 85±2°C Voltage : 200% of rated voltage. Time : 1000±⁴⁸₀hours</p>															
			<p>Temperature : 125±3°C Voltage : Rated voltage Time : 1000±⁴⁸₀hours</p>															

*C_R : Rated Capacitance(μF)

◆STANDARD RATINGS

Rated voltage (Vdc)	Rated Capacitance (μF)	Dimensions(mm)				Maximum ripple current (Arms)	Part Number	Previous Part Number (Just for your reference)	
		L	W	Tmax.	a				
25	0.33	2.0±0.2	1.25±0.2	1.25	0.3±0.2	0.2	KHC250E334M21N0T00	THCS20E1E334MTF	
	0.47						KHC250E474M21N0T00	THCS20E1E474MTF	
	0.68						KHC250E684M21N0T00	THCS20E1E684MTF	
	1.0	3.2±0.2	1.6±0.2	1.6	0.5±0.3	0.3	KHC250E105M31N0T00	THCS30E1E105MTF	
	1.5						KHC250E155M31N0T00	THCS30E1E155MTF	
	2.2						KHC250E225M31N0T00	THCS30E1E225MTF	
	3.3	3.2±0.2	2.5±0.2	2.0	0.6±0.3	0.5	KHC250E335M32N0T00	THCS40E1E335MTF	
	4.7						KHC250E475M32N0T00	THCS40E1E475MTF	
	6.8						KHC250E685M43N0T00	THCS50E1E685MTF	
	10	4.5±0.3	3.2±0.2	2.2	0.6±0.3	1.0	KHC250E106M43N0T00	THCS50E1E106MTF	
	15			3.0			KHC250E156M43N0T00	THCS50E1E156MTF	
	22			2.2			KHC250E226M55N0T00	THCS60E1E226MTF	
	33	5.7±0.4	5.0±0.4	3.0	0.8±0.5	2.0	KHC250E336M55N0T00	THCS60E1E336MTF	
	47			3.0			KHC250E476M76N0T00	THCS70E1E476MTF	
6.8	2.2			KHC250E685M55N0T00			THCS60E1H685MTF		
50	0.1	2.0±0.2	1.25±0.2	1.25	0.3±0.2	0.2	KHC500E104M21N0T00	THCS20E1H104MTF	
	0.15						KHC500E154M21N0T00	THCS20E1H154MTF	
	0.22						KHC500E224M21N0T00	THCS20E1H224MTF	
	0.33	3.2±0.2	1.6±0.2	1.6	0.5±0.3	0.3	KHC500E334M31N0T00	THCS30E1H334MTF	
	0.47						KHC500E474M31N0T00	THCS30E1H474MTF	
	0.68						KHC500E684M31N0T00	THCS30E1H684MTF	
	1.0	3.2±0.2	2.5±0.2	2.0	0.6±0.3	0.5	KHC500E105M32N0T00	THCS40E1H105MTF	
	1.5						KHC500E155M32N0T00	THCS40E1H155MTF	
	2.2						KHC500E225M32N0T00	THCS40E1H225MTF	
	3.3	4.5±0.3	3.2±0.2	2.2	0.6±0.3	1.0	KHC500E335M43N0T00	THCS50E1H335MTF	
	4.7			3.0			KHC500E475M43N0T00	THCS50E1H475MTF	
	6.8			2.2			KHC500E685M55N0T00	THCS60E1H685MTF	
	10	5.7±0.4	5.0±0.4	3.0	0.8±0.5	2.0	KHC500E106M55N0T00	THCS60E1H106MTF	
	15			3.0			KHC500E156M55N0T00	THCS60E1H156MTF	
22	2.5			KHC500E226M76N0T00			THCS70E1H226MTF		
100	0.047	2.0±0.2	1.25±0.2	1.25	0.3±0.2	0.2	KHC101E473M21N0T00	THCS20E2A473MTF	
	0.068						KHC101E683M21N0T00	THCS20E2A683MTF	
	0.1						KHC101E104M31N0T00	THCS30E2A104MTF	
	0.15	3.2±0.2	1.6±0.2	1.6	0.5±0.3	0.3	KHC101E154M31N0T00	THCS30E2A154MTF	
	0.22						KHC101E224M31N0T00	THCS30E2A224MTF	
	0.33						KHC101E334M32N0T00	THCS40E2A334MTF	
	0.47	3.2±0.2	2.5±0.2	2.0	0.6±0.3	0.5	KHC101E474M32N0T00	THCS40E2A474MTF	
	0.68			2.5			KHC101E684M32N0T00	THCS40E2A684MTF	
	1.0			2.2			KHC101E105M43N0T00	THCS50E2A105MTF	
	1.5	4.5±0.3	3.2±0.2	2.2	0.6±0.3	1.0	KHC101E155M43N0T00	THCS50E2A155MTF	
	2.2			3.0			KHC101E225M43N0T00	THCS50E2A225MTF	
	3.3			2.2			KHC101E335M55N0T00	THCS60E2A335MTF	
	4.7	5.7±0.4	5.0±0.4	3.0	0.8±0.5	2.0	KHC101E475M55N0T00	THCS60E2A475MTF	
	6.8			3.0			KHC101E685M76N0T00	THCS70E2A685MTF	
6.8	2.2			KHC101E685M76N0T00			THCS70E2A685MTF		
200	0.047	3.2±0.2	1.6±0.2	1.6	0.5±0.3	0.3	KHC201E473M31N0T00	THCS30E2D473MTF	
	0.068						KHC201E683M31N0T00	THCS30E2D683MTF	
	0.1						KHC201E104M32N0T00	THCS40E2D104MTF	
	0.15	3.2±0.2	2.5±0.2	2.0	0.6±0.3	0.5	KHC201E154M32N0T00	THCS40E2D154MTF	
	0.22						2.5	KHC201E224M32N0T00	THCS40E2D224MTF
	0.33						2.2	KHC201E334M43N0T00	THCS50E2D334MTF
	0.47	4.5±0.3	3.2±0.2	3.0	0.6±0.3	1.0	KHC201E474M43N0T00	THCS50E2D474MTF	
	0.68			2.2			KHC201E684M55N0T00	THCS60E2D684MTF	
	1.0			3.0			KHC201E105M55N0T00	THCS60E2D105MTF	
	1.5	5.7±0.4	5.0±0.4	2.5	0.8±0.5	2.0	KHC201E155M76N0T00	THCS70E2D155MTF	
	2.2			3.0			KHC201E225M76N0T00	THCS70E2D225MTF	
	2.2			2.5			KHC201E225M76N0T00	THCS70E2D225MTF	

◆PART NUMBERING SYSTEM

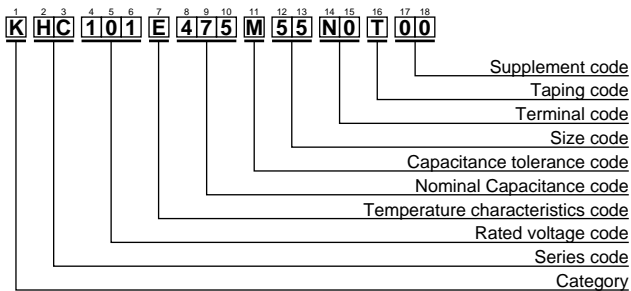

◆DIMENSIONS

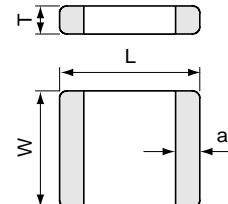

◆STANDARD RATINGS

Rated voltage (Vdc)	Rated Capacitance (μF)	Dimensions(mm)				Maximum ripple current (Arms)	Part Number	Previous Part Number (Just for your reference)						
		L	W	Tmax.	a									
25	0.68	3.2±0.2	1.6±0.2	1.6	0.4±0.2	0.3	KMC250E684M31N0T00	TMCS30E1E684MTF						
	1						KMC250E105M31N0T00	TMCS30E1E105MTF						
	1.5						KMC250E155M31N0T00	TMCS30E1E155MTF						
	2.2						KMC250E225M32N0T00	TMCS40E1E225MTF						
	3.3	3.2±0.2	2.5±0.2	2.2	0.5±0.2		0.5	KMC250E335M32N0T00	TMCS40E1E335MTF					
	4.7							KMC250E475M43N0T00	TMCS50E1E475MTF					
	6.8							4.5±0.3	3.2±0.2	2.5	0.5±0.3	KMC250E685M43N0T00	TMCS50E1E685MTF	
	10											KMC250E106M43N0T00	TMCS50E1E106MTF	
50	0.33	3.2±0.2	1.6±0.2	1.6	0.4±0.2	0.3		KMC500E334M31N0T00	TMCS30E1H334MTF					
	0.47							KMC500E474M31N0T00	TMCS30E1H474MTF					
	0.68							3.2±0.2	2.5±0.2	2.2	0.5±0.2	0.5	KMC500E684M32N0T00	TMCS40E1H684MTF
	1.0												KMC500E105M32N0T00	TMCS40E1H105MTF
	1.5	4.5±0.3	3.2±0.2	2.5	0.5±0.3		1.0	KMC500E155M32N0T00	TMCS40E1H155MTF					
	2.2							KMC500E225M43N0T00	TMCS50E1H225MTF					
	3.3							KMC500E335M43N0T00	TMCS50E1H335MTF					
	4.7							KMC500E475M43N0T00	TMCS50E1H475MTF					
100	0.1	3.2±0.2	1.6±0.2	1.6	0.4±0.2	0.3		KMC101E104M31N0T00	TMCS30E2A104MTF					
	0.15							KMC101E154M31N0T00	TMCS30E2A154MTF					
	0.22							3.2±0.2	2.5±0.2	2.2	0.5±0.2	0.5	KMC101E224M32N0T00	TMCS40E2A224MTF
	0.33												KMC101E334M32N0T00	TMCS40E2A334MTF
	0.47	4.5±0.3	3.2±0.2	2.5	0.5±0.3		1.0	KMC101E474M32N0T00	TMCS40E2A474MTF					
	0.68							KMC101E684M43N0T00	TMCS50E2A684MTF					
	1.0							KMC101E105M43N0T00	TMCS50E2A105MTF					
	1.5							KMC101E155M43N0T00	TMCS50E2A155MTF					
200	0.033	3.2±0.2	1.6±0.2	1.6	0.4±0.2	0.3		KMC201E333M31N0T00	TMCS30E2D333MTF					
	0.047							KMC201E473M31N0T00	TMCS30E2D473MTF					
	0.068							3.2±0.2	2.5±0.2	2.2	0.5±0.2	0.5	KMC201E683M32N0T00	TMCS40E2D683MTF
	0.1												KMC201E104M32N0T00	TMCS40E2D104MTF
	0.15	4.5±0.3	3.2±0.2	2.5	0.5±0.3		1.0	KMC201E154M32N0T00	TMCS40E2D154MTF					
	0.22							KMC201E224M43N0T00	TMCS50E2D224MTF					
	0.33							KMC201E334M43N0T00	TMCS50E2D334MTF					
	0.47							KMC201E474M43N0T00	TMCS50E2D474MTF					

◆PART NUMBERING SYSTEM

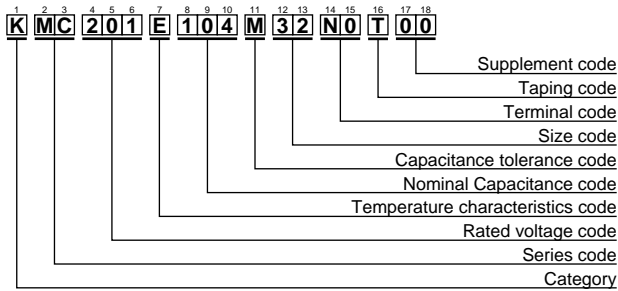

◆DIMENSIONS

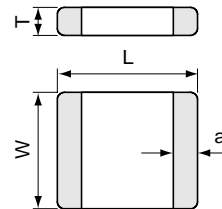



METAL CAP TYPE MULTILAYER CERAMIC CAPACITORS

THP Series / TMP Series (High Reliability)

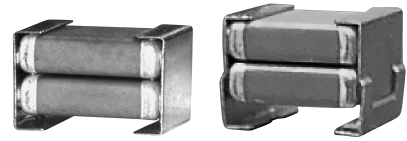

◆FEATURES

1. Small size and large capacitance, high ripple current.
2. Excellent temperature cycle durability and most suitable for aluminum substrate.
3. Y5U temperature characteristics.
4. Excellent noise absorption.
5. For reflow soldering use.
6. Suitable for aluminum substrate.

◆APPLICATIONS

1. Smoothing circuit of switching mode AC-DC or DC-DC converter.
2. On-board power supply.
3. Noise suppressor for various kinds of equipments.

◆CUSTOM MADE PRODUCTS

We can offer custom made one element metal cap type capacitors for request of customers. Please contact us if you have questions for details.

◆CONSTRUCTION

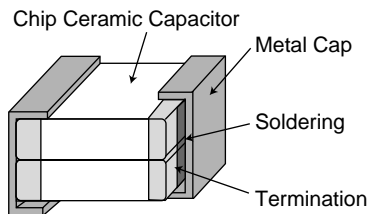

◆RATINGS

1. Category Temperature Range	-55~+125°C
2. Rated Voltage Range	25, 50, 100, 200V _{dc}
3. Rated Capacitance Range	0.45 to 100μF
4. Rated Capacitance Tolerance	M(±20%), Z(±20%)
5. Temperature Characteristics	E(JIS)≒Y5U(EIA)
6. Rated Ripple Current	See No.5 on the following table

◆SPECIFICATIONS

No.	Items	Specification	Test Condition								
1	Withstand Voltage	No abnormality.	250% of rated voltage shall be applied for 5 seconds.								
2	Insulation Resistance	1000/C _R (MΩ) or 10000(MΩ) whichever is less.	Rated voltage shall be applied for 60±5 seconds at temperature 20±2°C.								
3	Rated Capacitance	Within specified tolerance.	Temperature : 20±2°C Frequency : 1±0.1kHz (≥100μF, 120Hz) Voltage : 1±0.2Vrms								
4	Dissipation Factor	5.0% maximum	Temperature : 20±2°C Frequency : 1±0.1kHz (≥100μF, 120Hz) Voltage : 1±0.2Vrms								
5	Rated Ripple Current	<table border="1"> <tr> <td>Size</td> <td>43</td> <td>55</td> <td>76</td> </tr> <tr> <td>Arms</td> <td>1.5</td> <td>3.0</td> <td>4.0</td> </tr> </table>	Size	43	55	76	Arms	1.5	3.0	4.0	10kHz~1MHz (sine curve) Ripple voltage V _p shall be less than the rated voltage.
Size	43	55	76								
Arms	1.5	3.0	4.0								

◆SPECIFICATIONS

No.	Items	Specification	Test Condition															
6	Temperature Cycle	Appearance : No visible damage. $\Delta C/C : \pm 15\%$ D.F. : To meet the initial specification. I.R. : To meet the initial specification.	<table border="1"> <thead> <tr> <th>Step</th> <th>Temperature (°C)</th> <th>(min.)</th> </tr> </thead> <tbody> <tr> <td>1</td> <td>Min. Category temperature ± 3</td> <td>30\pm3</td> </tr> <tr> <td>2</td> <td>Room temperature</td> <td>3 max.</td> </tr> <tr> <td>3</td> <td>Max. Category temperature ± 3</td> <td>30\pm3</td> </tr> <tr> <td>4</td> <td>Room temperature</td> <td>3 max.</td> </tr> </tbody> </table> <Cycle> THP series : 100 cycles TMP series : 500 cycles	Step	Temperature (°C)	(min.)	1	Min. Category temperature ± 3	30 \pm 3	2	Room temperature	3 max.	3	Max. Category temperature ± 3	30 \pm 3	4	Room temperature	3 max.
Step	Temperature (°C)	(min.)																
1	Min. Category temperature ± 3	30 \pm 3																
2	Room temperature	3 max.																
3	Max. Category temperature ± 3	30 \pm 3																
4	Room temperature	3 max.																
7	Humidity Load Life	Appearance : No abnormality. $\Delta C/C : \pm 20\%$ D.F. : 7% max. I.R. : 50/C _R (M Ω) or 1000(M Ω) whichever is less.	Temperature : 40 \pm 2°C Humidity : 90 to 95%RH Voltage : Rated voltage Time : 500 \pm ²⁴ ₀ hours															
8	Endurance	Appearance : No abnormality. $\Delta C/C : \pm 20\%$ D.F. : 7% max. I.R. : 100/C _R (M Ω) or 1000(M Ω) whichever is less.	<table border="1"> <tbody> <tr> <td>Temperature : 85\pm2°C Voltage : 200% of rated voltage. Time : 1000\pm⁴⁸₀hours</td> </tr> <tr> <td>Temperature : 125\pm3°C Voltage : Rated voltage Time : 1000\pm⁴⁸₀hours</td> </tr> </tbody> </table>	Temperature : 85 \pm 2°C Voltage : 200% of rated voltage. Time : 1000 \pm ⁴⁸ ₀ hours	Temperature : 125 \pm 3°C Voltage : Rated voltage Time : 1000 \pm ⁴⁸ ₀ hours													
Temperature : 85 \pm 2°C Voltage : 200% of rated voltage. Time : 1000 \pm ⁴⁸ ₀ hours																		
Temperature : 125 \pm 3°C Voltage : Rated voltage Time : 1000 \pm ⁴⁸ ₀ hours																		

*C_R : Rated Capacitance(μ F)

◆Note of mountig for THP series.

1. The face of wider gap between a capacitor and a substrate shall be the mounting face.
2. To prevent degradation of temperature cycling capability, if need to be careful about amount of solder that would not go into the inner side of terminations.

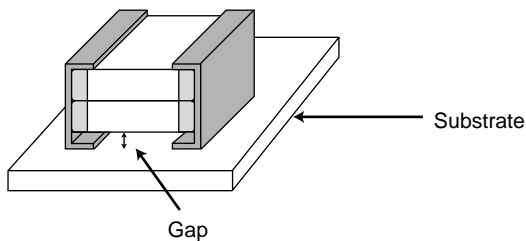

◆Note:

Single capacitor with metal cap is available upon request.
 Please consult us for details.

◆STANDARD RATINGS

Rated voltage (Vdc)	Rated Capacitance (μF)	Dimensions(mm)				Maximum ripple current (Arms)	Part Number	Previous Part Number (Just for your reference)
		L	W	Tmax.	a			
25	15	4.8±0.4	3.5±0.3	5.5	1.3±0.3	1.5	KHP250E156M435AT00	THP50E1E156MT502
	20			KHP250E206M435AT00			THP50E1E206MT502	
	33			KHP250E336M555AT00			THP60E1E336MT502	
	47	6.0±0.4	5.0±0.4	4.5	3.0	KHP250E476M555AT00	THP60E1E476MT502	
	68			5.6		KHP250E686M555AT00	THP60E1E686MT502	
	100			6.5		KHP250E107M765BT00	THP70E1E107MT502	
50	4.5	4.8±0.4	3.5±0.3	5.5	1.3±0.3	1.5	KHP500E455M435AT00	THP50E1H455MT502
	6.8			KHP500E685M435AT00			THP50E1H685MT502	
	10			KHP500E106M555AT00			THP60E1H106MT502	
	15	6.0±0.4	5.0±0.4	4.5	3.0	KHP500E156M555AT00	THP60E1H156MT502	
	22			5.6		KHP500E226M555AT00	THP60E1H226MT502	
	33			6.5		KHP500E336M765BT00	THP70E1H336MT502	
	47	7.8±0.5	6.6±0.5	6.5	1.5±0.3	4.0	KHP500E476M765BT00	THP70E1H476MT502
	15						KHP101E155M435AT00	THP50E2A155MT502
100	1.5	4.8±0.4	3.5±0.3	5.5	1.3±0.3	1.5	KHP101E205M435AT00	THP50E2A205MT502
	2.0			KHP101E305M435AT00			THP50E2A305MT502	
	3.0			KHP101E475M555AT00			THP60E2A475MT502	
	4.7	6.0±0.4	5.0±0.4	4.5	3.0	KHP101E685M555AT00	THP60E2A685MT502	
	6.8			5.6		KHP101E106M555AT00	THP60E2A106MT502	
	10			6.5		KHP101E156M765BT00	THP70E2A156MT502	
	15	7.8±0.5	6.6±0.5	6.5	1.5±0.3	4.0	KHP201E454M435AT00	THP50E2D454MT502
	0.45						KHP201E684M435AT00	THP50E2D684MT502
200	0.68	4.8±0.4	3.5±0.3	5.5	1.3±0.3	1.5	KHP201E105M435AT00	THP50E2D105MT502
	1.0			KHP201E155M555AT00			THP60E2D155MT502	
	1.5			4.5			KHP201E225M555AT00	THP60E2D225MT502
	2.2	6.0±0.4	5.0±0.4	5.6	3.0	KHP201E335M765BT00	THP70E2D335MT502	
	3.3			6.5		KHP201E475M765BT00	THP70E2D475MT502	
	4.7			6.5		1.5±0.3	4.0	

◆PART NUMBERING SYSTEM

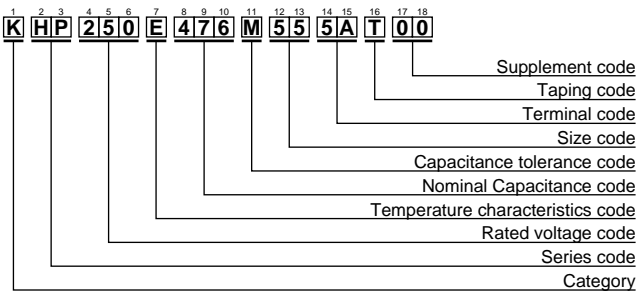

◆DIMENSIONS

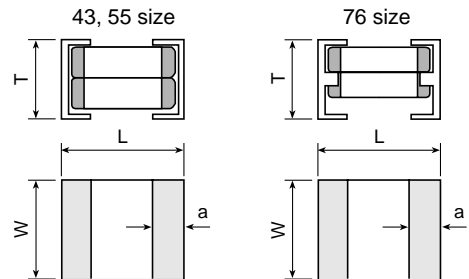

◆STANDARD RATINGS

Rated voltage (Vdc)	Rated Capacitance (μF)	Dimensions(mm)				Maximum ripple current (Arms)	Part Number	Previous Part Number (Just for your reference)
		L	W	Tmax.	a			
25	33	6.4±0.4	5.0±0.4	5.0	1.3±0.3	3.0	KMP250E336M555ET00	TMP60E1E336MT502
	47						KMP250E476M555ET00	TMP60E1E476MT502
	68	8.2±0.5	6.6±0.5	6.5	1.5±0.3	4.0	KMP250E686M765ET00	TMP70E1E686MT502
	100						KMP250E107M765ET00	TMP70E1E107MT502
50	10	6.4±0.4	5.0±0.4	5.0	1.3±0.3	3.0	KMP500E106M555ET00	TMP60E1H106MT502
	15						KMP500E156M555ET00	TMP60E1H156MT502
	22						KMP500E226M555ET00	TMP60E1H226MT502
	33	8.2±0.5	6.6±0.5	6.5	1.5±0.3	4.0	KMP500E336M765ET00	TMP70E1H336MT502
	47						KMP500E476M765ET00	TMP70E1H476MT502
	100						KMP101E106M765ET00	TMP60E2A106MT502
100	4.7	6.4±0.4	5.0±0.4	5.0	1.3±0.3	3.0	KMP101E475M555ET00	TMP60E2A475MT502
	6.8						KMP101E685M555ET00	TMP60E2A685MT502
	10	8.2±0.5	6.6±0.5	6.5	1.5±0.3	4.0	KMP101E106M765ET00	TMP70E2A106MT502
	15						KMP101E156M765ET00	TMP70E2A156MT502
200	1.5	6.4±0.4	5.0±0.4	5.0	1.3±0.3	3.0	KMP201E155M555ET00	TMP60E2D155MT502
	2.2						KMP201E225M555ET00	TMP60E2D225MT502
	3.3						KMP201E335M765ET00	TMP70E2D335MT502
	4.7	8.2±0.5	6.6±0.5	6.5	1.5±0.3	4.0	KMP201E475M765ET00	TMP70E2D475MT502
	100						KMP201E106M765ET00	TMP70E2A106MT502

◆PART NUMBERING SYSTEM

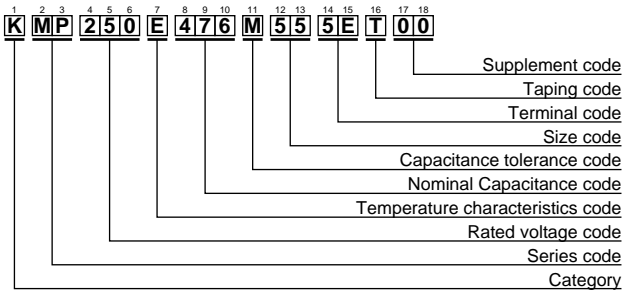

◆DIMENSIONS

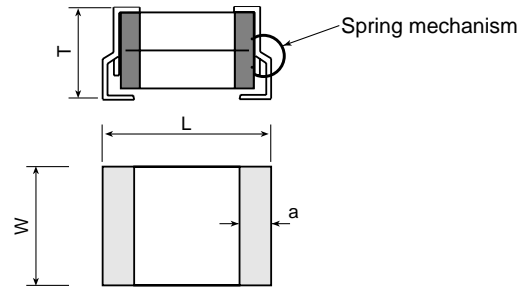



DIPPED RADIAL LEAD MULTILAYER CERAMIC CAPACITORS

THD Series

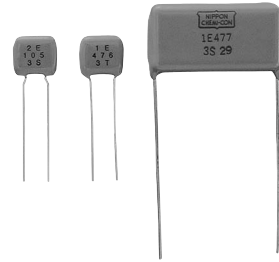

◆FEATURES

1. Small size and large capacitance, high ripple current.
2. Temperature characteristic is Y5U in EIA code.
3. Superior humidity characteristic and long life.
4. Excellent noise absorption.
5. Resin(UL94 V-0) used for coating.

◆APPLICATIONS

1. Automotive equipments.
2. Smoothing circuit of switching mode AC-DC or DC-DC converter.
3. Noise suppressor for various kinds of equipments.
4. By-pass or decoupling circuits.

◆CONSTRUCTION

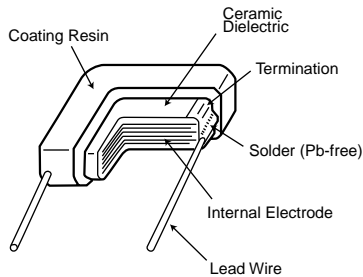

◆RATINGS

1. Category Temperature Range	-55 to +125°C
2. Rated Voltage Range	25, 50, 100, 250 V _{dc}
3. Rated Capacitance Range	0.1 to 470μF
4. Rated Capacitance Tolerance	M(±20%), Z(±20%)
5. Temperature Characteristics	E(JIS) ≒ Y5U(EIA)
6. Rated Ripple Current	See No.5 on the following table

◆SPECIFICATIONS

No.	Items		Specification	Test Condition
1	Withstand Voltage	Between Terminals	No abnormality.	250% of rated voltage shall be applied for 5 seconds.
		Terminals to Coating Resin		
2	Insulation Resistance		1000/C _R (MΩ) or 10000(MΩ) whichever is less.	Rated voltage shall be applied for 60±5 seconds at temperature 20±2°C.
3	Rated Capacitance		Within specified tolerance.	Temperature : 20±2°C Frequency : 1±0.1kHz(≥100μF, 120Hz) Voltage : 1±0.2V _{rms}
4	Dissipation Factor		5.0% maximum.	Temperature : 20±2°C Frequency : 1±0.1kHz(≥100μF, 120Hz) Voltage : 1±0.2V _{rms}

◆SPECIFICATIONS

No.	Items	Specification	Test Condition																		
5	Rated Ripple Current	<table border="1"> <tr> <td>Size code</td> <td>32</td> <td>43</td> <td>55</td> <td>76</td> <td>80</td> <td>90</td> <td>99</td> </tr> <tr> <td>Arms</td> <td>0.3</td> <td>0.8</td> <td>1.0</td> <td>1.5</td> <td>2.0</td> <td>3.0</td> <td>4.0</td> </tr> </table>	Size code	32	43	55	76	80	90	99	Arms	0.3	0.8	1.0	1.5	2.0	3.0	4.0	10kHz to 1MHz (sine curve) Ripple voltage V_p shall be less than the rated voltage.		
Size code	32	43	55	76	80	90	99														
Arms	0.3	0.8	1.0	1.5	2.0	3.0	4.0														
6	Robustness of Terminations	No visible damage.	The force applied shall be : <table border="1"> <tr> <td>Lead ϕ (mm)</td> <td>Tensile(N)</td> <td>(sec.)</td> </tr> <tr> <td>0.5 max.</td> <td>5</td> <td>10±1</td> </tr> <tr> <td>0.6 to 0.8 max.</td> <td>10</td> <td>10±1</td> </tr> </table> <table border="1"> <tr> <td>Lead ϕ (mm)</td> <td>Bending(N)</td> <td>(kg)</td> </tr> <tr> <td>0.5 max.</td> <td>2.5</td> <td>0.25</td> </tr> <tr> <td>0.6 to 0.8 max.</td> <td>5</td> <td>0.51</td> </tr> </table> Time : 2times.	Lead ϕ (mm)	Tensile(N)	(sec.)	0.5 max.	5	10±1	0.6 to 0.8 max.	10	10±1	Lead ϕ (mm)	Bending(N)	(kg)	0.5 max.	2.5	0.25	0.6 to 0.8 max.	5	0.51
Lead ϕ (mm)	Tensile(N)	(sec.)																			
0.5 max.	5	10±1																			
0.6 to 0.8 max.	10	10±1																			
Lead ϕ (mm)	Bending(N)	(kg)																			
0.5 max.	2.5	0.25																			
0.6 to 0.8 max.	5	0.51																			
7	Vibration	Appearance : No abnormality. Capacitance : To meet the initial specification. D.F. : To meet the initial specifications.	Amplitude : 1.5mm Frequency range : 10-55-10Hz (1 min) Direction and time : 2 hours each to X, Y, Z axis. Total 6 hours.																		
8	Solderability	Min. 75% of surface of the termination shall be covered with new solder.	<table border="1"> <tr> <td>Solder</td> <td>Pb Free</td> <td>Eutectic</td> </tr> <tr> <td>Solder Temperature</td> <td>245±5°C</td> <td>235±5°C</td> </tr> <tr> <td>Dipping Time</td> <td colspan="2">2±0.5sec.</td> </tr> </table>	Solder	Pb Free	Eutectic	Solder Temperature	245±5°C	235±5°C	Dipping Time	2±0.5sec.										
Solder	Pb Free	Eutectic																			
Solder Temperature	245±5°C	235±5°C																			
Dipping Time	2±0.5sec.																				
9	Resistance to Soldering Heat	Appearance : No abnormality. $\Delta C/C$: ±15% D.F. : Satisfy the initial spec.	Solder Temperature : 350±10°C Dipping Time : 3±0.5 sec. Depth : 1.5 to 2mm																		
10	Temperature Cycle	Appearance : No abnormality. $\Delta C/C$: ±15% D.F. : To meet the initial specification I.R. : To meet the initial specification	<table border="1"> <tr> <th>Step</th> <th>Temperature (°C)</th> <th>(min.)</th> </tr> <tr> <td>1</td> <td>Min. Category temperature ±3</td> <td>30±3</td> </tr> <tr> <td>2</td> <td>Room temperature</td> <td>3 max.</td> </tr> <tr> <td>3</td> <td>Max. Category temperature ±3</td> <td>30±3</td> </tr> <tr> <td>4</td> <td>Room temperature</td> <td>3 max.</td> </tr> </table> For 5 cycles for above temperature cycle.	Step	Temperature (°C)	(min.)	1	Min. Category temperature ±3	30±3	2	Room temperature	3 max.	3	Max. Category temperature ±3	30±3	4	Room temperature	3 max.			
Step	Temperature (°C)	(min.)																			
1	Min. Category temperature ±3	30±3																			
2	Room temperature	3 max.																			
3	Max. Category temperature ±3	30±3																			
4	Room temperature	3 max.																			
11	Humidity Load Life	Appearance : No abnormality. $\Delta C/C$: ±20% D.F. : 7% maximum I.R. : 50/ C_R (M Ω) or 1000(M Ω) whichever is less.	Temperature : 40±2°C Humidity : 90 to 95%RH Voltage : Rated voltage Time : 500± ₀ ²⁴ hours																		
12	Endurance	Appearance : No abnormality. $\Delta C/C$: ±20% D.F. : 7% maximum I.R. : 100/ C_R (M Ω) or 1000(M Ω) whichever is less.	Temperature : 85±2°C Voltage : 200% of rated voltage. Time : 1000± ₀ ⁴⁸ hours Temperature : 125±3°C Voltage : Rated voltage Time : 1000± ₀ ⁴⁸ hours																		

* C_R : Rated Capacitance(μ F)

◆PART NUMBERING SYSTEM

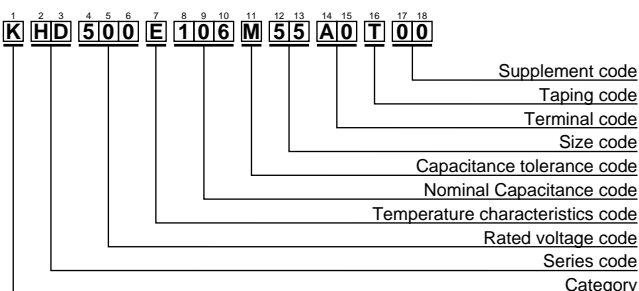

◆DIMENSIONS

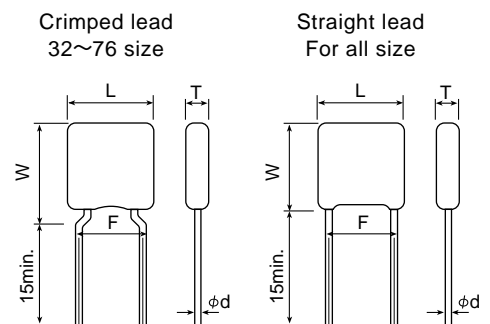



DIPPED RADIAL LEAD MULTILAYER CERAMIC CAPACITORS

THD Series

◆THD SERIES STANDARD RATINGS

Rated voltage (Vdc)	Rated Capacitance (μF)	Dimensions (mm)					Maximum ripple current (Arms)	Part Number	Previous Part Number (Just for your reference)	
		Lmax.	Wmax.	Tmax.	F±0.8	φd±0.05				
25	3.3	5.0	6.5	3.0	5.0	0.5	0.3	KHD250E335M32A0T00	THD21E1E335MT	
	4.7			3.5				KHD250E475M32A0T00	THD21E1E475MT	
	6.8	6.5	7.0	3.5	5.0	0.5	0.8	KHD250E685M43A0T00	THD30E1E685MT	
	10			4.0				KHD250E106M43A0T00	THD30E1E106MT	
	15			4.0				KHD250E156M43A0T00	THD30E1E156MT	
	22	7.5	9.0	4.0	5.0	0.5	1.0	KHD250E226M55A0T00	THD31E1E226MT	
	33			4.5				KHD250E336M55A0T00	THD31E1E336MT	
	47	10.0	11.5	4.5	10.0	0.6	1.5	KHD250E476M76A0T00	THD41E1E476MT	
	68			5.0				KHD250E686M80A0B00	THD51E1E686M	
	100	13.5	15.0	5.5	20.0	0.8	2.0	KHD250E107M80A0B00	THD51E1E107M	
	150			6.0				KHD250E157M90C0B00	THD60E1E157M	
	220	22.5	20.0	6.0	25.0	0.8	3.0	KHD250E227M90C0B00	THD60E1E227M	
	330			7.5				KHD250E337M99C0B00	THD61E1E337M	
	470	28.5	20.0	7.5	25.0	0.8	4.0	KHD250E477M99C0B00	THD61E1E477M	
50	1.0	5.0	6.5	3.0	5.0	0.5	0.3	KHD500E105M32A0T00	THD21E1H105MT	
	1.5			3.5				KHD500E155M32A0T00	THD21E1H155MT	
	2.2			3.5				KHD500E225M32A0T00	THD21E1H225MT	
	3.3	6.5	7.0	4.0	5.0	0.5	0.8	KHD500E335M43A0T00	THD30E1H335MT	
	4.7			4.0				KHD500E475M43A0T00	THD30E1H475MT	
	6.8	7.5	9.0	4.0	5.0	0.5	1.0	KHD500E685M55A0T00	THD31E1H685MT	
	10			4.5				KHD500E106M55A0T00	THD31E1H106MT	
	15			4.5				KHD500E156M55A0T00	THD31E1H156MT	
	22	10.0	11.5	4.5	10.0	0.6	1.5	KHD500E226M76A0T00	THD41E1H226MT	
	33			5.0				KHD500E336M80A0B00	THD51E1H336M	
	47	13.5	15.0	5.0	20.0	0.8	2.0	KHD500E476M90C0B00	THD60E1H476M	
	68			6.0				KHD500E686M90C0B00	THD60E1H686M	
	100	22.5	20.0	6.0	25.0	0.8	3.0	KHD500E107M90C0B00	THD60E1H107M	
	150			7.5				KHD500E157M99C0B00	THD61E1H157M	
	220	28.5	20.0	7.5	25.0	0.8	4.0	KHD500E227M99C0B00	THD61E1H227M	
	100	0.33	5.0	6.5	3.0	5.0	0.5	0.3	KHD101E334M32A0T00	THD21E2A334MT
		0.47			3.5				KHD101E474M32A0T00	THD21E2A474MT
		0.68			3.5				KHD101E684M32A0T00	THD21E2A684MT
1.0		6.5	7.0	3.5	5.0	0.5	0.8	KHD101E105M43A0T00	THD30E2A105MT	
1.5				4.0				KHD101E155M43A0T00	THD30E2A155MT	
2.2		7.5	9.0	4.0	5.0	0.5	1.0	KHD101E225M43A0T00	THD30E2A225MT	
3.3				4.5				KHD101E335M55A0T00	THD31E2A335MT	
4.7				4.5				KHD101E475M55A0T00	THD31E2A475MT	
6.8		10.0	11.5	4.5	10.0	0.6	1.5	KHD101E685M76A0T00	THD41E2A685MT	
10				5.0				KHD101E106M80A0B00	THD51E2A106M	
15		13.5	15.0	5.0	20.0	0.8	2.0	KHD101E156M80A0B00	THD51E2A156M	
22				6.0				KHD101E226M90C0B00	THD60E2A226M	
33		22.5	20.0	6.0	25.0	0.8	3.0	KHD101E336M90C0B00	THD60E2A336M	
47				7.5				KHD101E476M99C0B00	THD61E2A476M	
68		28.5	20.0	7.5	25.0	0.8	4.0	KHD101E686M99C0B00	THD61E2A686M	
100				7.5				KHD101E107M99C0B00	THD61E2A107M	
250		0.1	6.5	7.0	3.5	5.0	0.5	0.8	KHD251E104M43A0T00	THD30E2E104MT
		0.15			4.0				KHD251E154M43A0T00	THD30E2E154MT
	0.22	4.0			KHD251E224M43A0T00				THD30E2E224MT	
	0.33	4.0			KHD251E334M43A0T00				THD30E2E334MT	
	0.47	7.5	9.0	4.0	5.0	0.5	1.0	KHD251E474M55A0T00	THD31E2E474MT	
	0.68			4.5				KHD251E684M55A0T00	THD31E2E684MT	
	1.0	10.0	11.5	4.5	10.0	0.6	1.5	KHD251E105M76A0T00	THD41E2E105MT	
	1.5			5.0				KHD251E155M76A0T00	THD41E2E155MT	
	2.2	13.5	15.0	5.0	20.0	0.8	2.0	KHD251E225M80A0B00	THD51E2E225M	
	3.3			6.0				KHD251E335M90C0B00	THD60E2E335M	
	4.7	22.5	20.0	6.0	25.0	0.8	3.0	KHD251E475M90C0B00	THD60E2E475M	
	6.8			7.5				KHD251E685M99C0B00	THD61E2E685M	
	10	28.5	20.0	7.5	25.0	0.8	4.0	KHD251E106M99C0B00	THD61E2E106M	
	15			7.5				KHD251E156M99C0B00	THD61E2E156M	

◆Temperature and DC voltage Characteristics

●NTS series (X7R) 25V

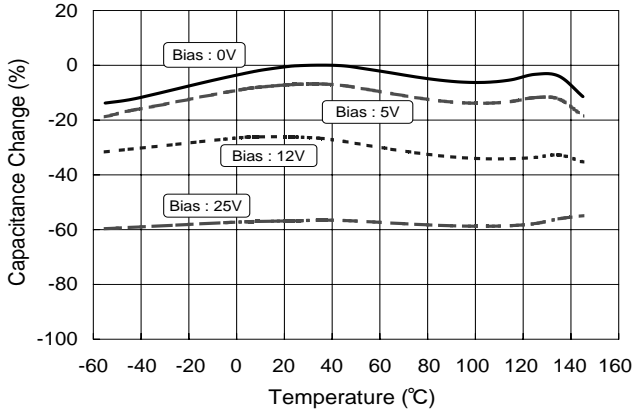

●THC/THD series (Y5U) 25V

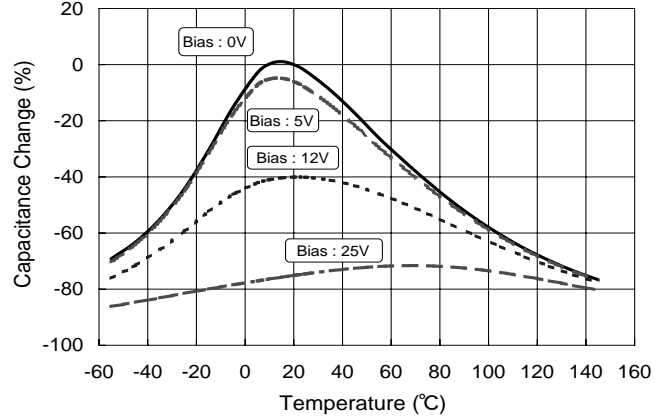

●NTS series (X7R) 50V

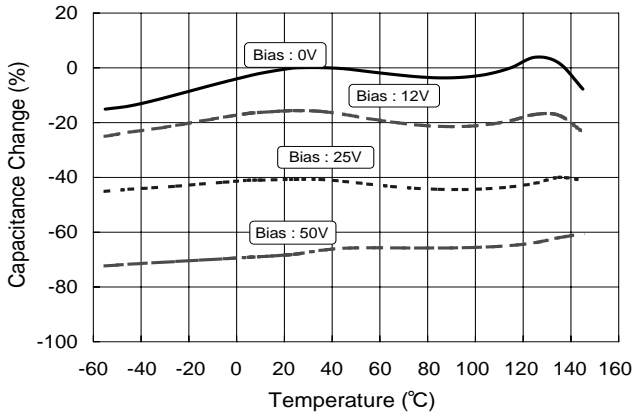

●THC/THD series (Y5U) 50V

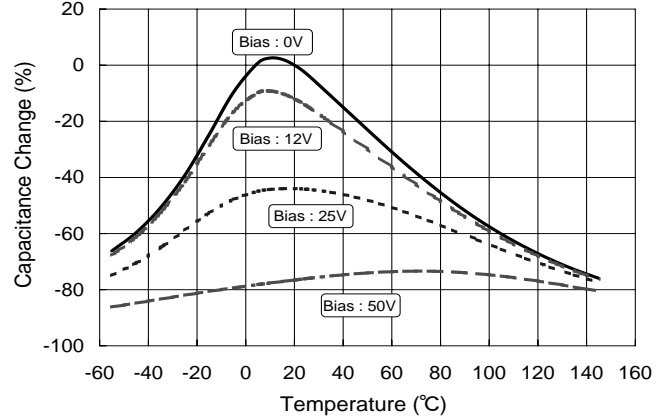

●NTS series (X7R) 100V

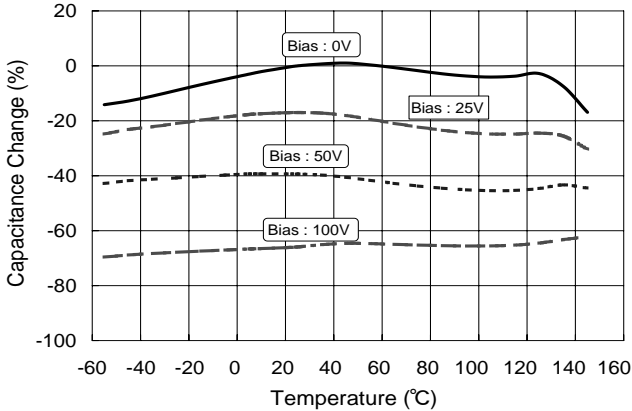

●THC/THD series (Y5U) 100V

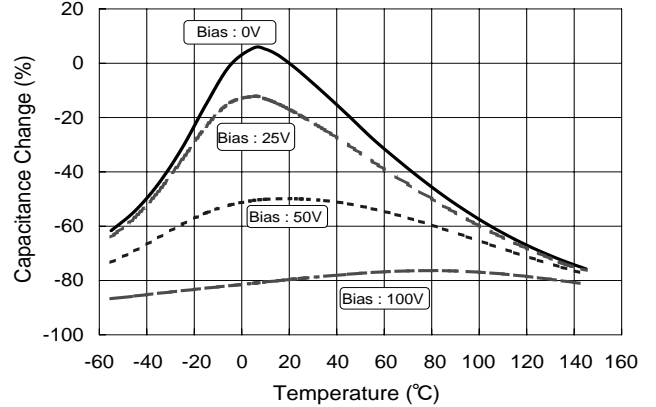

●NTS series (X7R) 250V

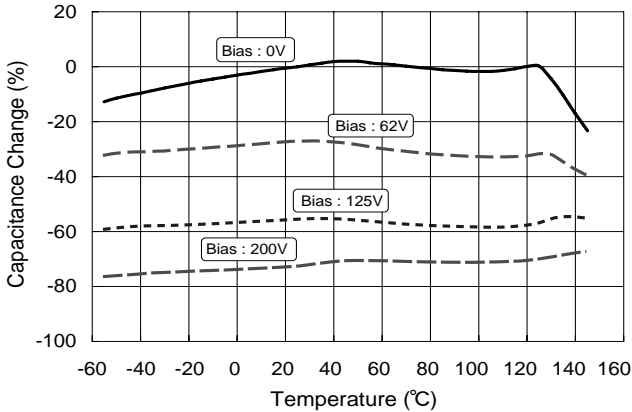

●THC/THD series (Y5U) 200V

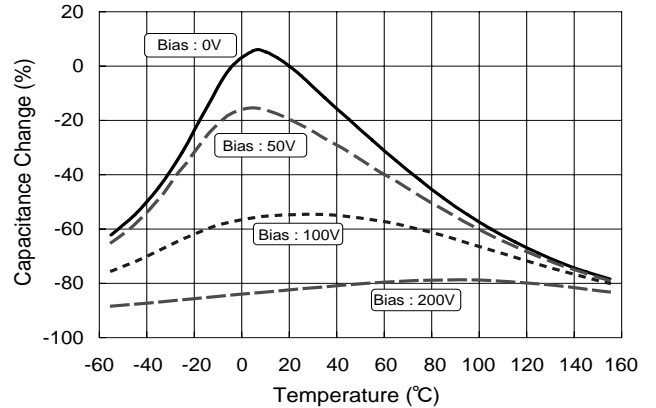

◆Frequency Characteristics

●NTS Series 25V/33 μ F

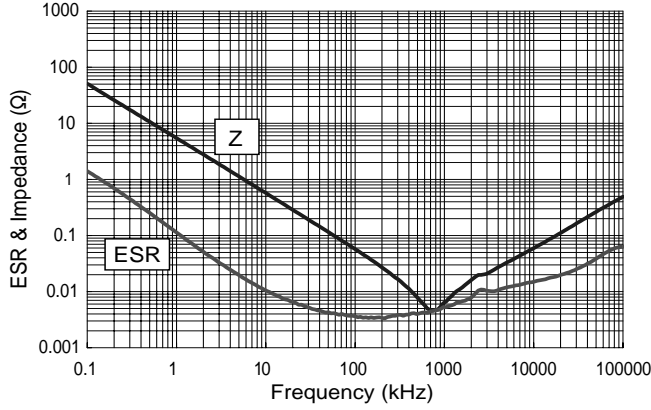

●THC Series 25V/10 μ F

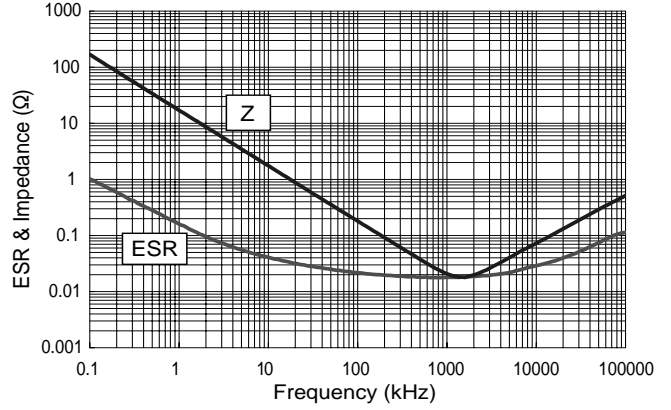

●NTS Series 50V/15 μ F

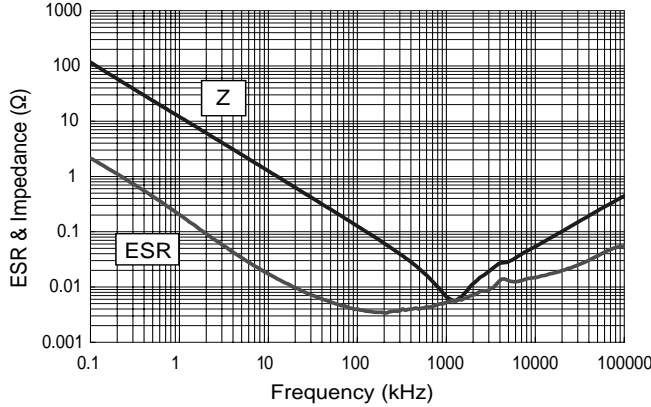

●THC Series 50V/10 μ F

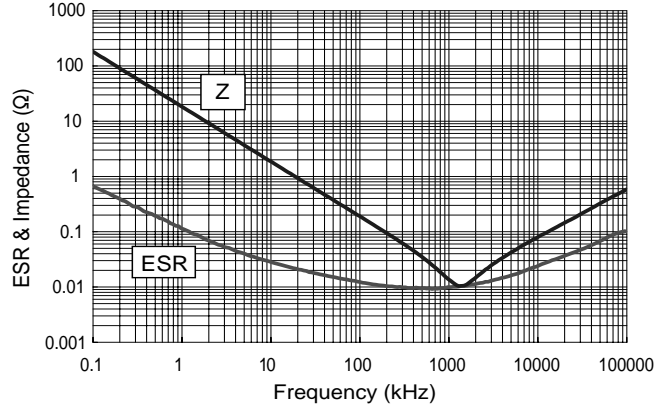

●NTS Series 100V/6.8 μ F

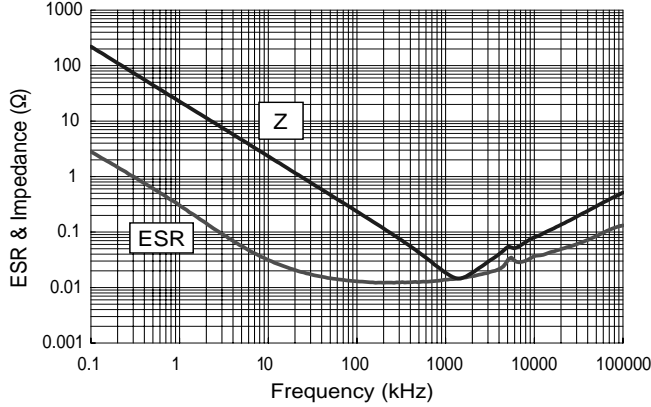

●THC Series 100V/2.2 μ F

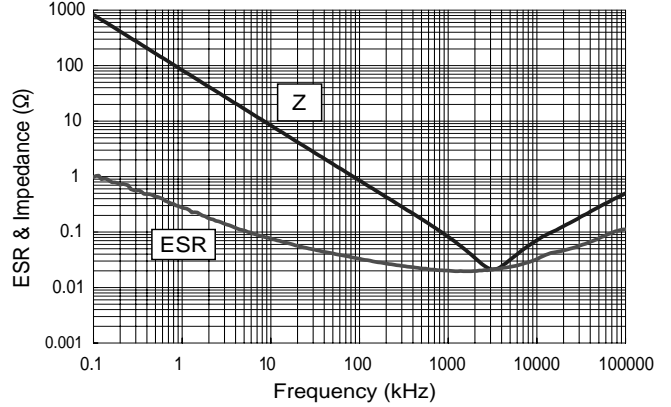

●NTS Series 250V/1.0 μ F

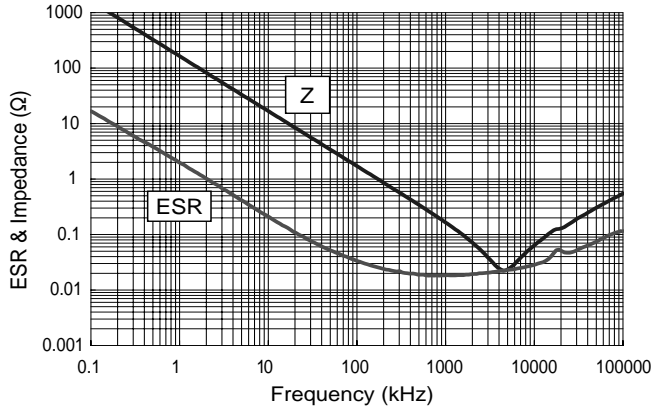

●THC Series 200V/1.5 μ F

