

## Amorphous metal and NIPPON CHEMI-CON Amorphous Choke Coil

The amorphous metal has non crystalline structure generated by cooling molten metal rapidly. Due to the amorphous structure, the amorphous metal has excellent magnetic, mechanical, and chemical features in comparison with conventional metallic substances. NIPPON CHEMI-CON started developing amorphous components for electronic and electric equipment by making full use of the material and process technologies at its early stages and has continued the synthetic research and development to optimally match the amorphous choke coils with the material features and their applications through a variety of characteristics. NIPPON CHEMI-CON will help the customers design smaller and higher performance products by supplying excellent amorphous choke coils through the sophisticated production technology and manufacturing know-how.

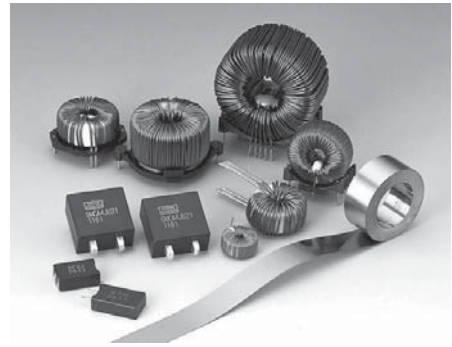

## STANDARD SPECIFICATIONS

### ◆General Specification of Toroidal Coil

Items	Amorphous coils Rated value	Dust coils Rated value
Operating temperature range *1	-40 to 130°C	-40 to 120°C (Coating type) -40 to 130°C (Case type)
Storage temperature range	-40 to 130°C	-40 to 120°C (Coating type) -40 to 130°C (Case type)
Operating humidity range *1	20 to 95%RH	
Storage humidity range	20 to 80%RH	
Operating frequency range *2	20kHz to 500kHz	
Temperature rise *3	40K or less	
Insulation type	Type B (130°C)	Type A(105°C) Coating type Type B(130°C) Case type
Incombustibility	UL 94 V-0	

\*1 Temperature on the coil surface including the temperature rise in installation. Never use the coil at a temperature exceeding the rated temperature range.

\*2 Recommended range. When infra-acoustic frequency component is impressed, a beat sound sometimes occurs.

\*3 The temperature rise on the coil surface at the rated d.c. current.

Note carefully that the temperature of the core may exceed the operating temperature range depending on the circumference condition even if the coil is used in the specification ranges described above.

### ◆DIMENSIONS

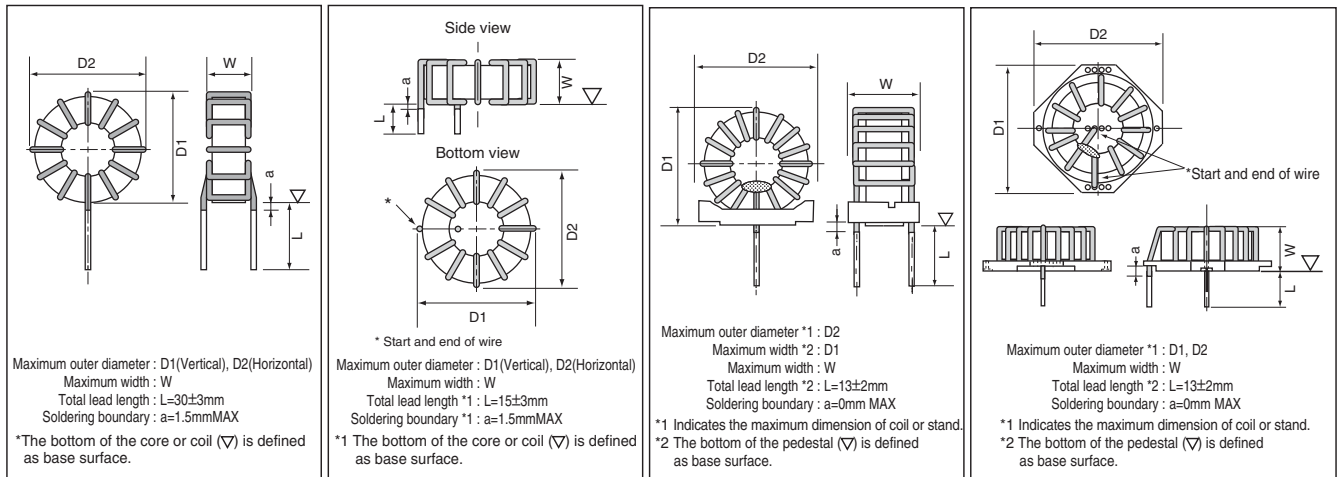

### ◆Notes on use

- Note that the lead wire may not be subject to excess force and also may not be bent repeatedly because the wire is made of copper.
- Never make the coil hit on a hard and/or sharp substance. If so, the coating of the coils may be damaged to ruin the performance of the coil.
- Contact NIPPON CHEMI-CON for how to clean the substrate on which the coil is mounted.
- When infra-acoustic frequency component is impressed, a beat sound sometimes occurs.
- Regarding compliance for EU REACH Regulation
  - (1) According to the content of REACH handbook (Guidance on requirements for substances in articles which is published on May 2008), our electronic components are "articles without any intended release". Therefore they are not applicable for "Registration" for EU REACH Regulation Article 7 (1).  
Reference: Electrolytic Condenser Investigation Society  
"Study of REACH Regulation in EU about Electrolytic Capacitor" (publicized on 13 March 2008)
  - (2) Nippon Chemi-Con develops the products without substance of very high concern(SVHC).DEHP(CASNo.117-81-7) was contained as some covering material, Nippon Chemi-Con abolished use of DEHP totally at June, 2011.



# AMORPHOUS / DUST CHOKE COILS

Series	Major uses	Miniaturization	Thin type	Low loss	Low cost	Large capacity	Classification
<b>CM</b>	Switching mode power supplies DC-DC converter Normal mode line filter	◎		○		○	Toroidal with gap
<b>CMJ</b>	Switching mode power supplies Step up and down converter	◎		○		○	
<b>AM</b>	Harmonic counter-measure active filter Normal mode line filter	◎		○		○	
<b>AW</b>	Harmonic counter-measure active filter Uninterruptible power supply system (UPS)	◎		○		◎	
<b>TM</b>	Switching mode power supplies DC-DC converter Normal mode line filter	○	○	○	○		Toroidal without gap
<b>BM</b>	Switching mode power supplies DC-DC converter Normal mode line filter	◎	○	○	◎		
<b>DM</b>	DC-DC converter Switching mode power supplies Harmonic counter-measure active filter	○	◎	○	◎	◎	Dust
<b>SM</b>	DC-DC converter Switching mode power supplies	◎	◎	○	○		Package
<b>FM</b>	Line filter for inverter or large power supply High frequency transformer	◎		○		◎	Common mode
Accessories							
AMORPHOUS CHOKE COIL Characteristics							
Coil Design Request							

## GLOBAL CODE SYSTEM

The current parts numbering system is changed to new system for global coding.

Your cooperation will be very much appreciated.

①Rated Current code    ②Rated Inductance code    ③Core Abbreviation code    ④Mounting Direction code

Code	Rated Current	Code	Rated Inductance	Code	Core Abbreviation	Code	Mounting Direction
0R5	0.5A	0R5	0.5μH	N6-	N6	V	Vertical
001	1A	010	1μH	JRH	JRH	H	Horizontal
010	10A	100	10μH			D	Vertical pedestal
100	100A	101	100μH			B	Horizontal pedestal
		102	1000μH			Y	Vertical pedestal with pins
						W	Horizontal pedestal with pins

⑤Specifications control code    ⑥Solder control code

Code	Specifications	Code	Specifications
0	Standard	0	Not Pb free
1	Custom	E	Pb free

Series: L B TM 0110 3010 N6- V 0 E  
 Section code: 0110  
 Class code: 3010

## COIL SERIES GUIDE

