

## Product code guide (Snap-in type)

(Example : KMM series, 400V-220 $\mu$ F,  $\phi$ 30 $\times$ 30L)

Please refer to the following table

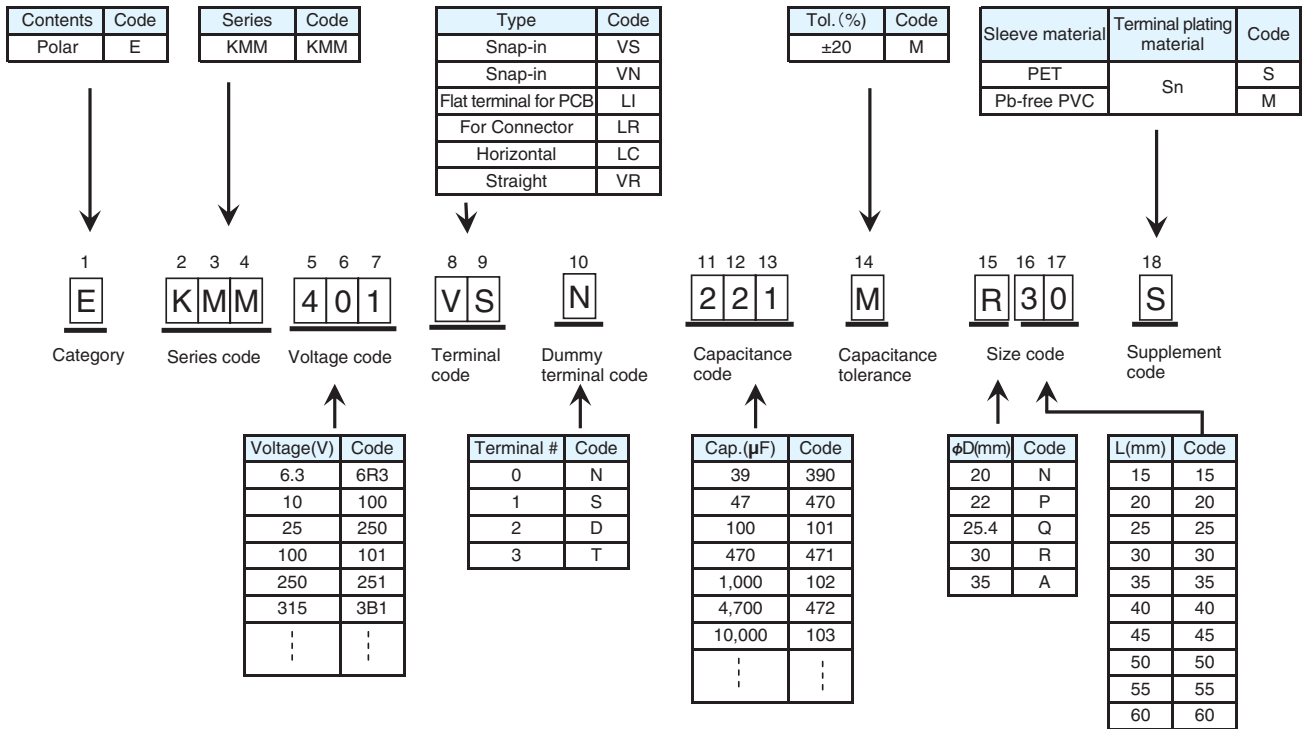

\*Refer to the appendix (Part number) for codes not listed here.