



ALUMINUM ELECTROLYTIC CAPACITORS

CAT. No. E1001L

INDEX		
PRODUCT SEARCH	SERIES TABLE	➔
	GROUP CHART	➔
PRODUCT GUIDE	PRECAUTIONS AND GUIDELINES (Conductive Polymer)	➔
	PRECAUTIONS AND GUIDELINES (Aluminum Electrolytic Capacitor)	➔
	PART NUMBERING SYSTEM	➔
	ENVIRONMENTAL CONSIDERATION	➔
	PACKAGING	➔
	TAPING SPECIFICATIONS	➔
	AVAILABLE TERMINALS FOR SNAP-IN AND SCREW-MOUNT TYPE	➔
	STANDARDIZATION	➔
	WORLD-WIDE MANUFACTURING LOCATIONS	➔
	RECOMMENDED REFLOW CONDITION	➔



CAPACITOR SERIES TABLE, CONTENTS

Series		Features	Endurance (+R=With ripple)	Standard Type	Low impedance	Solvent resistant	Terminal type	Rated voltage range (Vdc)	Capacitance range (μ F)	
Conductive Polymer Electrolyte Type	Surface Mount Type	PXK <small>(NEW!)</small>	Super low ESR, high ripple current, downsized	105°C 1,000 to 2,000 hours		●	SMD	2.5 to 16	100 to 560	
		PXS	Long life, super low ESR, high ripple current	105°C 5,000 hours		●	SMD	4 to 16	22 to 560	
		PXF <small>(Upgrade!)</small>	Super low ESR, high ripple current	105°C 2,000 hours		●	SMD	2 to 6.3	150 to 1,000	
		PXE	Super low ESR, high ripple current	105°C 2,000 hours		●	SMD	2.5 to 16	33 to 2,700	
		PXA	Super low ESR, high ripple current	105°C 1,000 to 2,000 hours	●	●	SMD	2.5 to 25	3.3 to 1,500	
		PXH	125°C, super low ESR, high ripple current	125°C 1,000 hours		●	SMD	2.5 to 20	22 to 1,000	
	Radial Lead Type	PSG <small>(NEW!)</small>	Long life, super low ESR, high ripple current	105°C 2,000 to 5,000 hours		●	●	Radial	16 to 25	56 to 1,000
		PSK <small>(NEW!)</small>	Long life, super low ESR, high ripple current	105°C 5,000 hours		●	●	Radial	2.5	220 to 560
		PSF <small>(Upgrade!)</small>	Long life, super low ESR, high ripple current	105°C 5,000 hours		●	●	Radial	2.5 to 16	100 to 1,600
		PSE	Long life, super low ESR, high ripple current	105°C 5,000 hours		●	●	Radial	2.5 to 6.3	470 to 820
		PSC	Super low ESR, high ripple current	105°C 2,000 hours		●	●	Radial	2.5 to 16	270 to 2,700
		PSA	Super low ESR, high ripple current	105°C 2,000 hours	●	●	●	Radial	2.5 to 16	47 to 1,500
	PS	Super low ESR, high ripple current	105°C 2,000 hours	●	●	●	Radial	2.5 to 35	18 to 1,500	
Surface Mount Type	General Purpose	MVA	85°C, standard	85°C 2,000 hours	●		SMD	4 to 450	1.0 to 10,000	
		MVE	105°C, standard	105°C 1,000 to 2,000 hours	●		SMD	6.3 to 450	1.0 to 6,800	
	Low Impedance	MZJ <small>(NEW!)</small>	Super low ESR	105°C 2,000 hours		●	●	SMD	6.3 to 35	10 to 1,800
		MZA	Super low impedance	105°C 2,000 hours		●	●	SMD	6.3 to 80	3.3 to 1,500
		MVY	Low impedance, standard, Case size ϕ 4 to 18mm	105°C 1,000 to 5,000 hours	●	●	▲	SMD	6.3 to 100	1.0 to 8,200
		MZF <small>(NEW!)</small>	10,000 hours, Long life, low impedance	105°C 10,000 hours		●	●	SMD	6.3 to 50	10 to 470
		MZE	7,000/8,000 hours, Long life, low impedance	105°C 7,000 to 8,000 hours		●	●	SMD	6.3 to 50	10 to 470
		MZK <small>(NEW!)</small>	5,000 hours, Long life, low impedance	105°C 5,000 hours		●	●	SMD	6.3 to 35	10 to 150
		MLA	3,000 hours, Long life, low impedance	105°C 3,000 hours		●	●	SMD	6.3 to 50	10 to 1,000
	Long Life	MLF <small>(NEW!)</small>	10,000 hours, Long life	105°C 10,000 hours			●	SMD	6.3 to 50	1.0 to 1,000
		MLE	7,000/8,000 hours, Long life	105°C 7,000 to 8,000 hours			●	SMD	6.3 to 50	1.0 to 1,000
		MLK <small>(NEW!)</small>	5,000 hours, Long life	105°C 5,000 hours			●	SMD	6.3 to 35	4.7 to 100
		MVL	3,000/5,000 hours, Long life	105°C 3,000 to 5,000 hours			●	SMD	6.3 to 50	1.0 to 1,000
		MVJ	2,000 hours, Long life	105°C 2,000 hours			●	SMD	6.3 to 50	1.0 to 100
	Special Application	MVH	125°C, Case size ϕ 6.3 to 18mm	125°C 1,000 to 5,000 hours	●		▲	SMD	10 to 450	3.3 to 4,700
		MHB <small>(Upgrade!)</small>	125°C, Specified ESR after endurance	125°C 2,000 hours			●	SMD	10 to 35	47 to 470
		MHJ <small>(NEW!)</small>	125°C, Specified ESR after endurance	125°C 2,000 hours			●	SMD	10 to 35	47 to 470
		MKB	Specified ESR at low temperature	105°C 3,000 hours				SMD	400	2.2 to 4.7
		MV-BP	Bi-polar	85°C 2,000 hours			●	SMD	6.3 to 50	1.0 to 47
		MVK-BP	Bi-polar	105°C 1,000 hours			●	SMD	6.3 to 50	1.0 to 47
	Radial Lead Type	Low Profile	SRM	5mm height, downsized	85°C 1,000 hours			●	Radial	4 to 50
SRE			85°C, 5mm height, standard	85°C 1,000 hours	●			Radial	4 to 50	1.0 to 100
KRE			105°C, 5mm height, standard	105°C 1,000 hours	●		●	Radial	6.3 to 50	1.0 to 100
SRA			85°C, 7mm height, standard	85°C 1,000 hours	●			Radial	4 to 63	1.0 to 470
KMA			105°C, 7mm height, standard	105°C 1,000 hours	●		●	Radial	4 to 63	1.0 to 220
SRG			ϕ 4×7 to ϕ 18×25mm, low profile	85°C 1,000 to 2,000 hours			●	Radial	4 to 50	1.0 to 10,000
KRG			ϕ 4×7 to ϕ 18×25mm, low profile	105°C 1,000 hours			●	Radial	6.3 to 50	1.0 to 10,000
General Purpose		SMQ	85°C, Downsized	85°C 2,000 hours				Radial	6.3 to 450	1.0 to 47,000
		KMQ	105°C, Downsized	105°C 1,000 to 2,000 hours +R			▲	Radial	6.3 to 450	1.0 to 47,000
		SMG	85°C, standard	85°C 2,000 hours	●		▲	Radial	6.3 to 450	1.0 to 39,000
		KMG	105°C, standard	105°C 1,000 to 2,000 hours +R	●		▲	Radial	6.3 to 450	1.0 to 22,000
		SME-BP	Bi-polar, downsized	85°C 2,000 hours			●	Radial	6.3 to 100	1.0 to 6,800
		KME-BP	Bi-polar, downsized	105°C 1,000 hours			●	Radial	6.3 to 100	1.0 to 6,800
High Frequency Use		KZM	Long life, super low impedance	105°C 6,000 to 10,000 hours +R		●		Radial	6.3 to 50	27 to 10,000
		KZH	Super low impedance, downsized	105°C 5,000 to 6,000 hours +R		●		Radial	6.3 to 35	47 to 8,200
		KZE	Low impedance, downsized	105°C 1,000 to 5,000 hours +R		●		Radial	6.3 to 100	6.8 to 6,800
		KYA <small>(NEW!)</small>	Low impedance, downsized	105°C 4,000 to 10,000 hours +R		●		Radial	6.3 to 100	1 to 15,000
		KY	Low impedance, standard	105°C 4,000 to 10,000 hours +R	●	●		Radial	6.3 to 100	1.0 to 18,000
		LZA <small>(NEW!)</small>	Low impedance, downsized (Ask Engineering Bulletin No804 in detail)	105°C 4,000 to 5,000 hours +R		●	●	Radial	6.3 to 35	330 to 6,800
		LXZ	Low impedance, downsized	105°C 2,000 to 8,000 hours +R	●	●	●	Radial	6.3 to 63	12 to 18,000
		LXY	Low impedance	105°C 2,000 to 8,000 hours +R		●	●	Radial	10 to 63	10 to 8,200
LXV		Low impedance	105°C 2,000 to 5,000 hours +R		●	●	Radial	6.3 to 100	5.6 to 15,000	

● : Recommendation products

▲ : Some of range are solvent resistant.

Product specifications in this catalog are subject to change without notice. Request our product specifications before purchase and/or use. Please use our products based on the information contained in this catalog and product specifications.

Series		Features	Endurance (+R=With ripple)	Standard Type	Low impedance	Solvent resistant	Terminal type	Rated voltage range (V _{dc})	Capacitance range (μF)	
Radial Lead Type	High Reliability	KXJ	Long life, downsized, for input filtering	105°C 10,000 to 12,000 hours +R			Radial	160 to 450	6.8 to 680	
		KXG	Long life, downsized, for input filtering	105°C 8,000 to 10,000 hours +R	●		Radial	160 to 450	6.8 to 330	
		SMH	For input filtering, φ20×20 to φ22×50mm (Ask Engineering Bulletin No808 in detail)	85°C 2,000 hours +R			Radial	160 to 450	33 to 470	
		KMH	For input filtering, φ20×20 to φ22×50mm (Ask Engineering Bulletin No810 in detail)	105°C 2,000 hours +R			Radial	160 to 450	33 to 470	
		PAG	Low profile, for input filtering	105°C 2,000 hours +R			Radial	200 to 450	18 to 560	
		KLJ	No sparks with DC overvoltage, downsized	105°C 2,000 hours +R			Radial	200 & 400	4.7 to 330	
		KLG	No sparks with DC overvoltage	105°C 2,000 hours +R			Radial	200 & 400	22 to 330	
		FL	Long life, downsized	105°C 3,000 hours +R			●	Radial	6.3 to 50	1.0 to 270
		GPA	125°C, low impedance, downsized	125°C 3,000 to 5,000 hours +R	●	●	Radial	25 to 50	470 to 6,800	
		GXE	125°C, low impedance, downsized	125°C 2,000 to 5,000 hours +R	●	▲	Radial	10 to 450	4.7 to 4,700	
		GXL	125°C	125°C 5,000 hours +R			●	Radial	10 to 50	100 to 1,000
	GXH (NEW!)	135°C	135°C 1,500 / 2,000 hours +R			●	Radial	10 to 50	100 to 4,700	
	Special Application	LBG	For airbag	105°C 5,000 hours +R		●	●	Radial	25 & 35	1,000 to 11,000
		KZA	For PC motherboard (Ask Engineering Bulletin No809 in detail)	105°C 2,000 hours +R		●		Radial	6.3 to 16	470 to 3,300
LLA		Low DC leakage, general (Ask Engineering Bulletin No575 in detail)	85°C 1,000 hours			●	Radial	6.3 to 50	1.0 to 15,000	
PH		For photo flash	55°C 5,000 times charging				Radial	300 & 330	—	
Snap-in Type	General Purpose	SMQ	85°C, standard	85°C 2,000 hours +R	●		Pin	160 to 450	82 to 3,900	
		KMW (NEW!)	Super downsized (Ask Engineering Bulletin No806 in detail)	105°C 2,000 hours +R			Pin	400 to 450	120 to 1,000	
		KMR	Super downsized	105°C 2,000 hours +R			Pin	160 to 450	100 to 3,300	
		KMQ	105°C, standard	105°C 2,000 hours +R	●		Pin	35, 50, 160 to 450	68 to 33,000	
		KMT (NEW!)	High ripple (Ask Engineering Bulletin No807 in detail)	105°C 2,000 hours +R			Pin	420 & 450	56 to 470	
		SMM	85°C, 3,000 hours	85°C 3,000 hours +R	●		Pin	160 to 450	47 to 3,300	
		KMS (Upgrade!)	105°C, Downsized	105°C 3,000 hours +R	●		Pin	160 to 500	47 to 3,300	
		KMM	105°C, 2,000/3,000 hours	105°C 2,000 to 3,000 hours +R	●		Pin	160 to 450	39 to 3,300	
		SMH	85°C, standard (Ask Engineering Bulletin No585 for 160 to 450V)	85°C 2,000 hours +R			Pin	6.3 to 100	820 to 100,000	
	KMH	105°C, standard (Ask Engineering Bulletin No584 for 160 to 450V)	105°C 2,000 hours +R			Pin	6.3 to 100	560 to 82,000		
	Low Profile	SLM	15mm height, low profile	85°C 2,000 hours +R			Pin	160 to 400	47 to 560	
		KLM	15mm height, low profile	105°C 2,000 hours +R			Pin	160 to 400	39 to 390	
	High Reliability	LXM	Long life, downsized	105°C 7,000 hours +R			Pin	160 to 450	47 to 2,200	
		LXS (Upgrade!)	Long life, downsized	105°C 5,000 hours +R	●		Pin	160 to 500	82 to 3,300	
		LXQ	Long life, downsized	105°C 5,000 hours +R			Pin	160 to 450	82 to 2,700	
		LXG	Long life	105°C 5,000 hours +R			Pin	10 to 100	390 to 47,000	
		CHA (Upgrade!)	No sparks with DC overvoltage, downsized	105°C 2,000 hours +R			Pin	200 to 450	56 to 1,200	
LXH		No sparks with DC overvoltage	105°C 3,000/5,000 hours +R			Pin	200 & 400	68 to 1,500		
KMV (NEW!)	For charge and discharge application	105°C 3,000 hours +R			Pin	350 to 450	82 to 1,200			
Screw-Mount Type	General Purpose	SME	85°C, standard (Ask Engineering Bulletin No548 for 160 to 250V)	85°C 2,000 hours +R	●		Screw	10 to 100	2,200 to 680,000	
		KMH	105°C, standard	105°C 2,000 hours +R	●		Screw	10 to 400	180 to 680,000	
	For Inverter	RWG	Long life, high ripple, downsized	85°C 5,000 hours +R			Screw	350 to 450	1,500 to 18,000	
		RWF	Long life, high ripple	85°C 5,000 hours +R			Screw	350 to 450	820 to 22,000	
		RWQ	High ripple, downsized	85°C 2,000 hours +R	●		Screw	350 to 550	390 to 15,000	
		RWE	High ripple	85°C 2,000 hours +R	●		Screw	350 to 550	100 to 12,000	
		RWY	Long life, high ripple, low cost	85°C 5,000 hours +R			Screw	350 to 450	500 to 14,000	
		RWL	Long life, high ripple	85°C 20,000 hours +R			Screw	350 to 450	2,200 to 12,000	
		FTP	Ellips can shape, high ripple	85°C 5,000 hours +R			Screw	63 to 450	270 to 21,000	
		LXA	105°C, long life	105°C 2,000/5,000 hours +R			Screw	10 to 525	330 to 390,000	
		LXR	105°C, long life, high ripple	105°C 5,000 hours +R			Screw	350 to 450	2,200 to 15,000	
RWV (NEW!)	For charge and discharge application	85°C 5,000 hours +R			Screw	350 to 450	820 to 18,000			

■ : Recommendation products

▲ : Some of range are solvent resistant.

CONDUCTIVE POLYMER ALUMINUM SOLID CAPACITORS

◆ SURFACE MOUNT

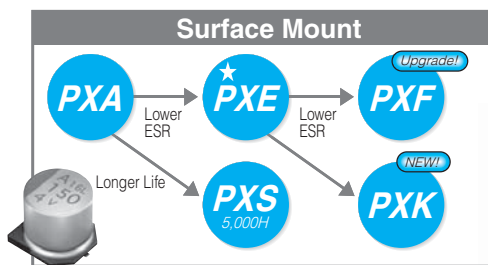

◆ RADIAL LEAD



ALUMINUM ELECTROLYTIC CAPACITORS

◆ SURFACE MOUNT

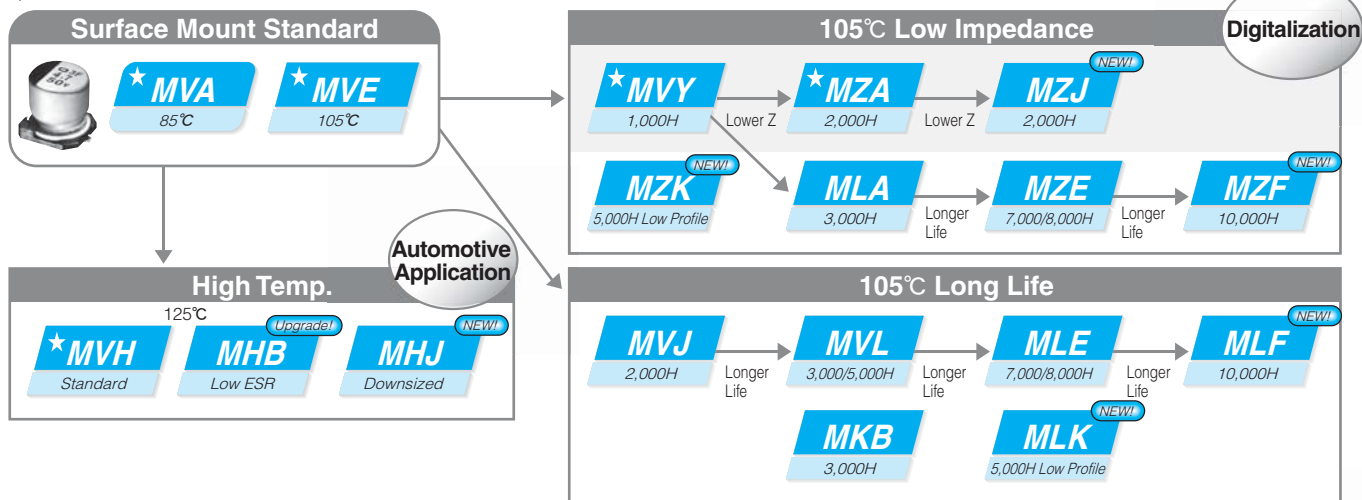

◆ RADIAL LEAD

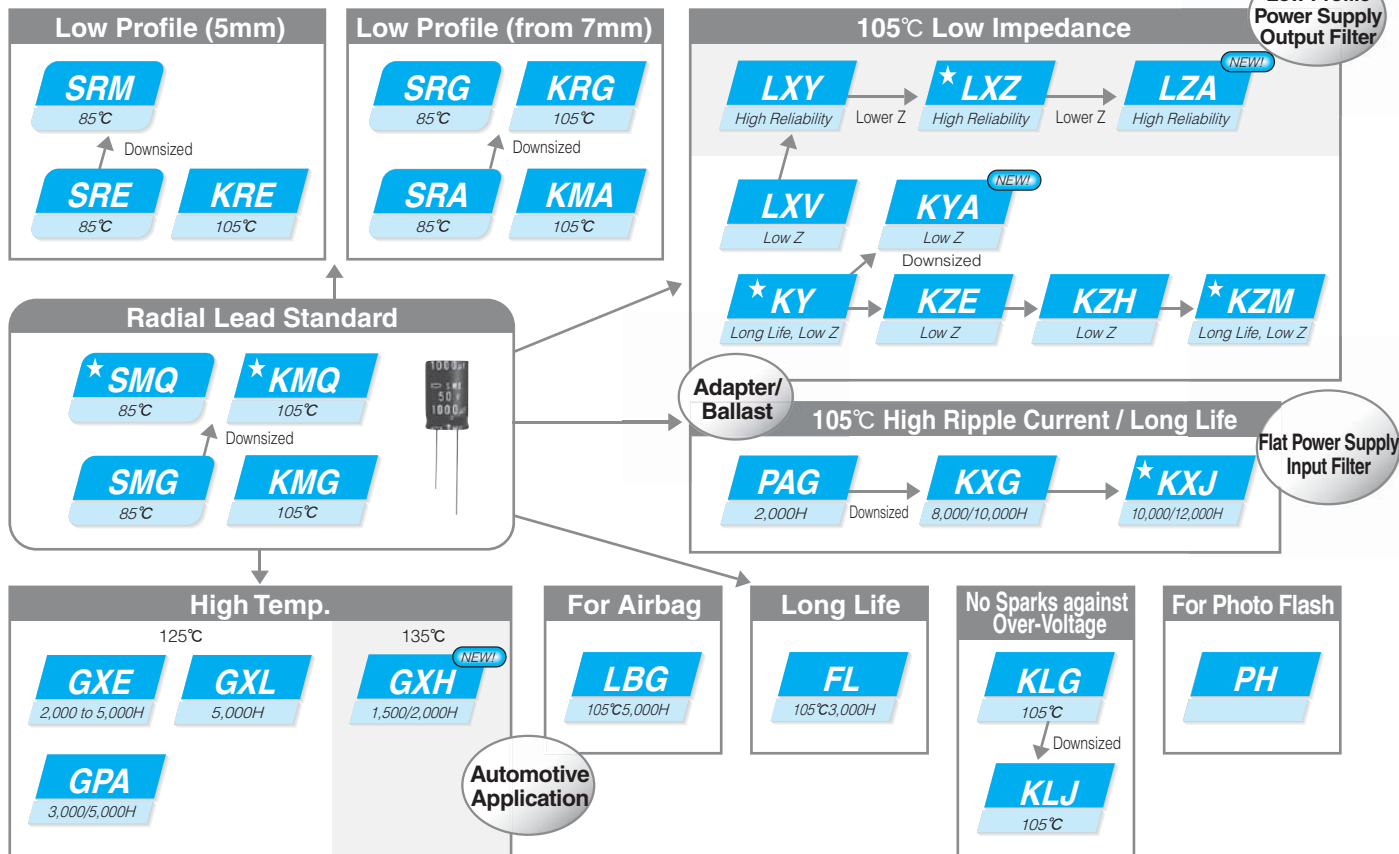

☆: Recommendation products

ALUMINUM ELECTROLYTIC CAPACITORS

◆SNAP-IN

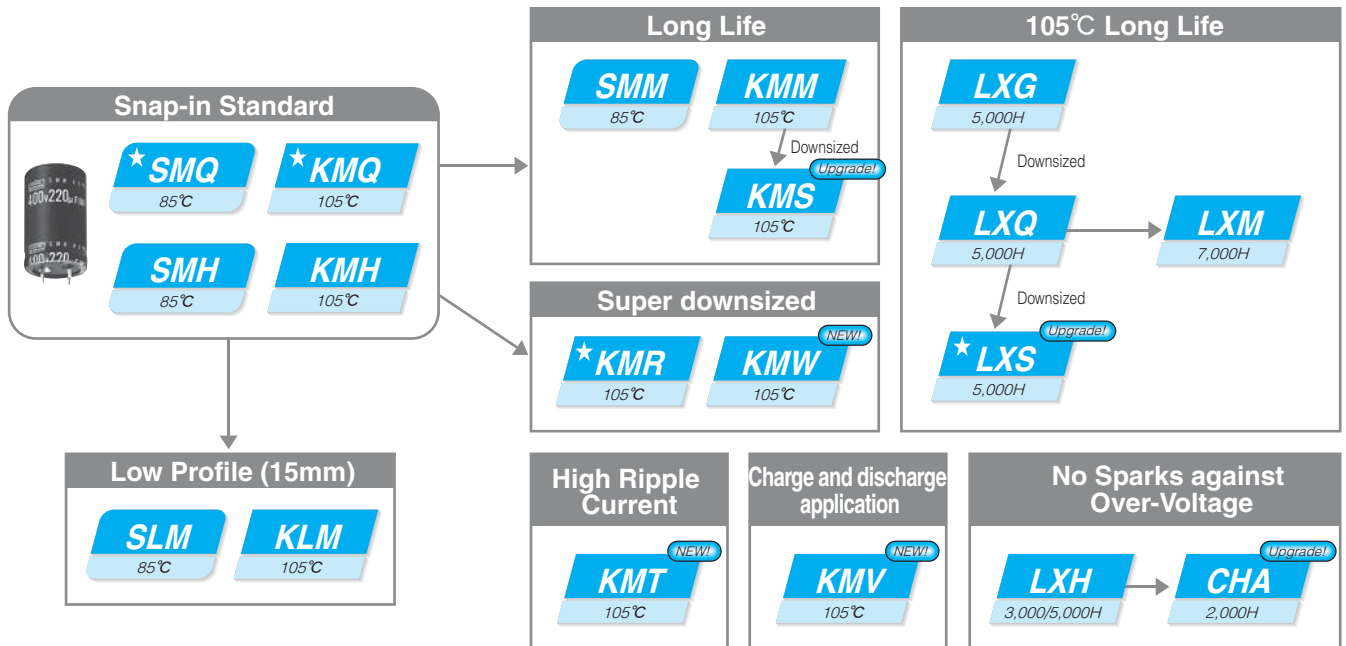

◆SCREW-MOUNT TERMINAL

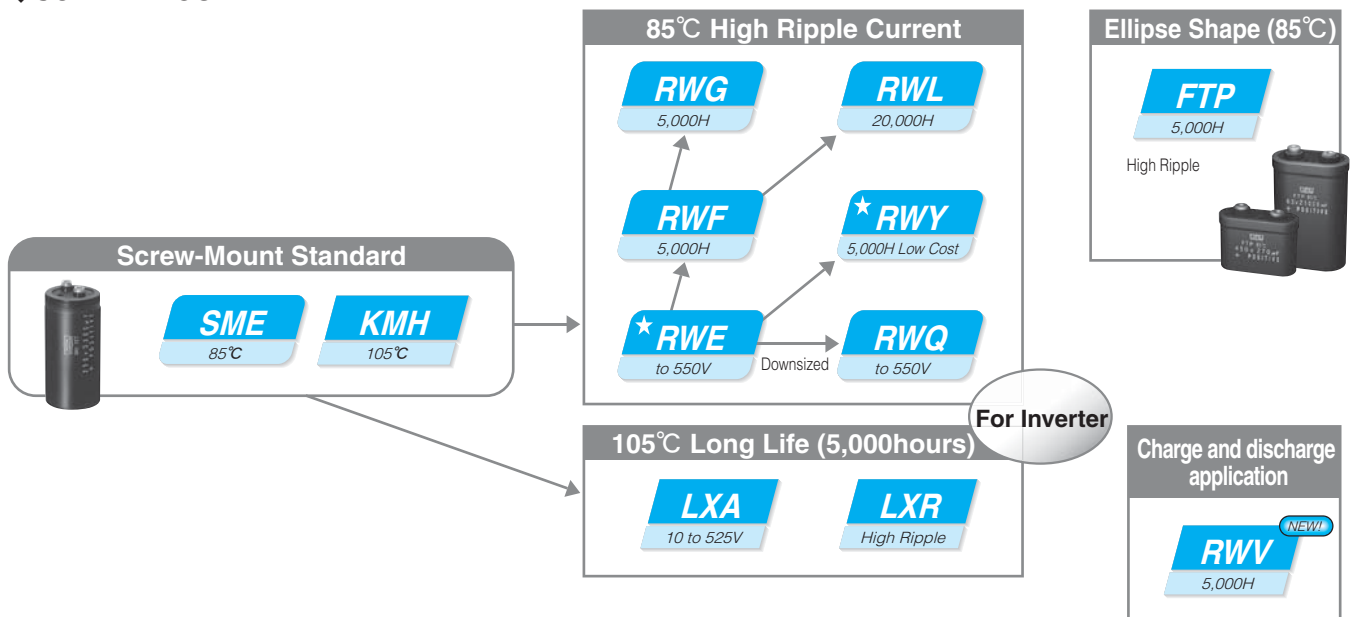

☆: Recommendation products



PART NUMBERING SYSTEM

Part numbering system

Our part numbering system is common to all of Nippon Chemi-Con's subsidiaries worldwide, and has been switching the conventional part numbering system. The part number uses 18-digit codes to express information of principal product specifications such as product category, series name, rated voltage, capacitance, case size and RoHS compliance.

●Categories

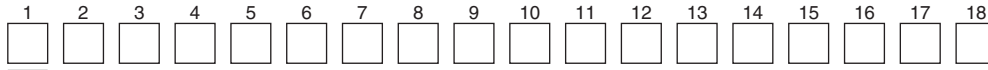

Code	Details
A	Conductive Polymer Aluminum Solid Capacitors (Polar)
E	Aluminum Electrolytic Capacitors (Polar)
B	Aluminum Electrolytic Capacitors (Bi-polar)
K	Multilayer Ceramic Capacitors
F,W	Film Capacitors
D	Electric Double Layer Capacitors
T	Metal Oxide Varistors
L	Amorphous Choke Coils

* For digits 2 to 18, please see "Product code guide".

●Example

Product type	Part number (Example)	Conventional part number (Ref.)
Surface mount type	EMVE160ADA100MD55G	MVE16VC10MD55E0
Radial lead type	EKMQ6R3ETC102MHB5D	TC04RKMQ6.3VB1000MF50E0
Snap-in type	EKMQ201VSN471MP30S	KMQ200VSSN470M22BE0
Screw mount terminal type	ERWE551LGC821MCD0M	RWE550LGSN820MCC13EA



Environment friendly capacitors

Nippon Chemi-Con always considers the environment in product materials, designs and manufacturing. In fact, our factories already have received ISO 14000 certificate. Cadmium, Mercury, Hexavalent Chromium, PBB and PBDE have never been used in our products. Furthermore, lead-containing materials have been eliminated from all our aluminum electrolytic capacitors including Conductive Polymer Aluminum Solid Capacitors to comply with RoHS. If you need "Halogen-Free" products, please consult with us.

◆Lead free and Non-PVC Products

1. Lead wire (Plating)

Category		Plating material on lead wires
Chip	case code : D46 to JA0	Sn-Bi
	case code : KE0 to MN0	Sn
Radial	case dia : ~φ8	Sn-Bi
	case dia : φ10~	Sn
Snap-in		Sn
Screw-Mount		Originally lead-free

*Please consult with us when you need "Lead-free parts" other than the above mentioned terminal plating materials.
(Note) Sn : Tin, Bi : Bismuth

2. Sleeve

Category		Sleeve material
Chip		Sleeveless(Coating case)
Radial	φ8×5L	Sleeveless(Coating case)
	except φ8×5L	PET
Snap-in		PET
Screw-Mount		PVC(Lead-free)

* Please consult with us when you need "Non-PVC parts" other than the above mentioned outer sleeve materials.

The colors of a PET sleeve are "Black", "Brown", and "Dark blue".
Standard designs of "lead-free" Snap-in type are not equipped with a plastic disc.
Please consult with us when you need nonflammable grade for outer sleeve material.

Identification of friendly parts is given by a supplement code (18th digit) of the part number.
For details, please refer to "Product code guide" for each type.

◆Regarding compliance for EU REACH Regulation

1) According to the content of REACH handbook (Guidance on requirements for substances in articles which is published on May 2008), our electronic components are "articles without any intended release". Therefore they are not applicable for "Registration" for EU REACH Regulation Article 7 (1).

Reference: Electrolytic Condenser Investigation Society

"Study of REACH Regulation in EU about Electrolytic Capacitor" (publicized on 13 March 2008)

2) Nippon Chemi-Con develops the products without substance of very high concern(SVHC).DEHP(CASNo.117-81-7) was contained as some covering material, Nippon Chemi-Con abolished use of DEHP totally at June, 2011.

TAPING SPECIFICATIONS
SURFACE MOUNT TYPE (TAPING)



◆CARRIER TAPE [mm]

Fig.1

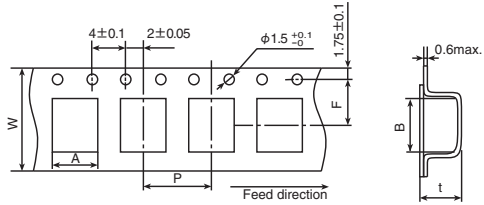

Fig.3

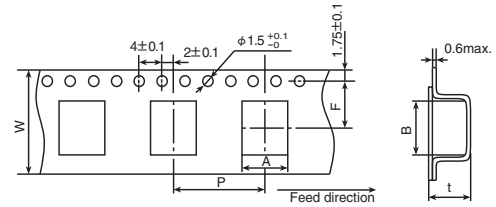

Fig.2

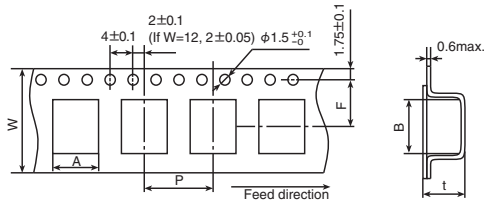
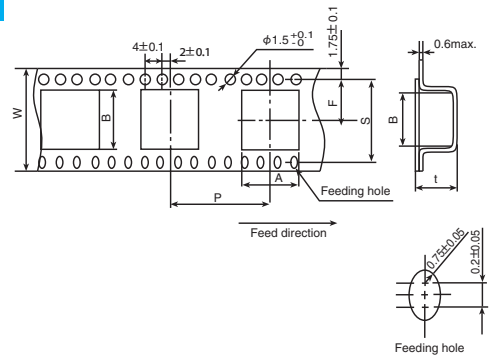

Fig.4



[mm]

Series	Items	W	A	B	F	P	t	S	Fig.	
		±0.3	±0.2	±0.2	±0.1	±0.1	±0.2	±0.1		
Alchip™ MVA/MVE MZJ/MZA MVY/MZF MZE/MZK MLA/MLF MLE/MLK MVL/MVJ MVH/MHB MHJ/MKB MV-BP MVK-BP	D55	12.0	4.7	4.7	5.5	8.0	5.7	—	1	
	D60,D61	12.0	4.7	4.7	5.5	8.0	6.3	—	1	
	D73	12.0	4.6	4.6	5.5	8.0	7.5	—	1	
	E55	12.0	5.7	5.7	5.5	12.0	5.7	—	2	
	E60,E61	12.0	5.7	5.7	5.5	12.0	6.3	—	2	
	E73	16.0	5.7	5.7	7.5	12.0	7.5	—	2	
	F46	16.0	7.0	7.0	7.5	12.0	4.9	—	2	
	F55	16.0	7.0	7.0	7.5	12.0	5.7	—	2	
	F60,F61	16.0	7.0	7.0	7.5	12.0	6.3	—	2	
	F73	16.0	7.0	7.0	7.5	12.0	7.5	—	2	
	F80	16.0	7.0	7.0	7.5	12.0	8.2	—	2	
	F90	16.0	7.0	7.0	7.5	12.0	9.2	—	2	
	H63	16.0	8.7	8.7	7.5	12.0	6.8	—	2	
	H70	24.0	8.7	8.7	11.5	12.0	7.3	—	2	
	H80	24.0	8.7	8.7	11.5	12.0	8.3	—	2	
	HA0	24.0	8.7	8.7	11.5	16.0	11.0	—	3	
	HC0	24.0	8.7	8.7	11.5	16.0	12.7	—	3	
	NPCAP™ PXK/PXS PXF/PXE PXA/PXH	J80	24.0	10.7	10.7	11.5	16.0	8.3	—	3
		JA0	24.0	10.7	10.7	11.5	16.0	11.0	—	3
		JC0	24.0	10.7	10.7	11.5	16.0	12.8	—	3
KE0		32.0	13.4	13.4	14.2	24.0	14.0	28.4	4	
KG5		32.0	13.4	13.4	14.2	24.0	16.5	28.4	4	
LH0		44.0	17.5	17.5	20.2	28.0	16.8	40.4	4	
LN0		44.0	17.5	17.5	20.2	28.0	22.1	40.4	4	
MH0		44.0	19.5	19.5	20.2	32.0	17.1	40.4	4	
MN0	44.0	19.5	19.5	20.2	32.0	22.1	40.4	4		

◆ REEL DIMENSIONS [mm]

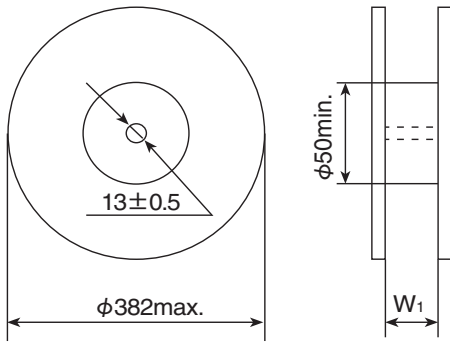

◆ POLARITY

- Alchip™ -MVA/MVE/MZJ
MZA/MVY/MZF
MZE/MZK/MLA
MLF/MLE/MLK
MVL/MVJ/MVH
MHB/MHJ/MKB
MV-BP/MVK-BP
NPCAP™ PXX/PXS/PXF
PXE/PXA/PXH

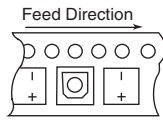

◆ QUANTITY PER REEL/BOX

Series	Size code	Quantity (pcs/reel)	Quantity (pcs/box)	W ₁ (mm)
Alchip™	D55,D60,D61	2,000	10,000	14
	D73	1,500	7,500	14
	E55,E60,E61	1,000	5,000	14
	E73	1,000	5,000	18
	F55,F60,F61,F73	1,000	5,000	18
	F80	900	4,500	18
	F90	800	4,000	18
	H63	1,000	5,000	18
	HA0	500	1,500	26
	JA0	500	1,500	26
	KE0	200	600	34
	KG5	150	450	34
	LH0	125	250	46
	LN0	75	150	46
	MH0	125	250	46
	MN0	75	150	46
	NPCAP™	D55	2,000	20,000
E60,E61		1,000	10,000	14
F46,F55,F60,F61		1,000	7,000	18
F80		900	6,300	18
H70		1,000	6,000	26
H80		900	5,400	26
HA0		500	3,000	26
HC0		400	1,200	26
J80		500	3,000	26
JA0		500	3,000	26
JC0		400	1,200	26

SURFACE MOUNT TYPE (TRAY)

◆ DIMENSIONS [mm]

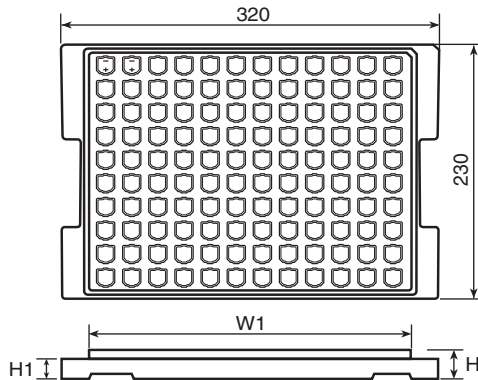

● TRAY CODE : TR

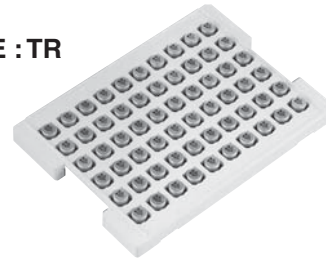

Size code	H [mm]	W ₁ [mm]	H ₁ [mm]	Quantity [pcs/tray]	Quantity [pcs/box]
KE0 & KG5	21.0	284	18.5	120	600
LH0 & LN0	28.0	284	24.0	80	400
MH0 & MN0	28.0	284	24.0	60	300

VIBRATION RESISTANT STRUCTURE (Terminal code : G)

◆ DIMENSIONS [mm]

- Terminal code : G
- Size code : HA0 to JA0

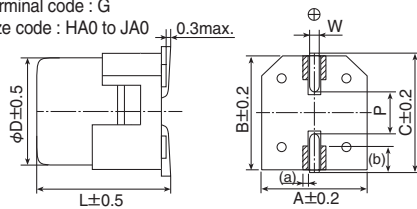

▨ : Dummy terminals

- Size code : KE0 to MN0

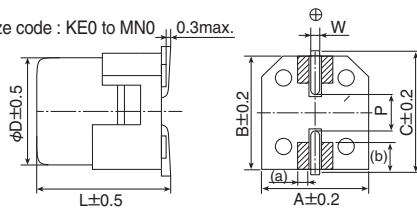

▨ : Dummy terminals

◆ RECOMMENDED SOLDER LAND

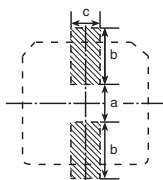

▨ Solder land on PC board

Size code	Dimensions of products (mm)									Solder land (mm)		
	D	L	A	B	C	W	P	(a)	(b)	a	b	c
HA0	8.0	10.0	8.3	8.3	9.0	0.7 to 1.1	3.1	(0.5)	(1.8)	3.1	4.2	3.5
JA0	10.0	10.0	10.3	10.3	11.0	0.7 to 1.1	4.5	(0.5)	(2.1)	4.5	4.4	3.5
KE0	12.5	13.5	13.0	13.0	13.7	1.0 to 1.3	4.2	(1.3)	(3.0)	3.4	6.3	9.3
KG5	12.5	16.0	13.0	13.0	13.7	1.0 to 1.3	4.2	(1.3)	(3.0)	3.4	6.3	9.3
LH0	16.0	16.5	17.0	17.0	18.0	1.0 to 1.3	6.5	(2.0)	(3.0)	4.7	7.8	9.6
LN0	16.0	21.5	17.0	17.0	18.0	1.0 to 1.3	6.5	(2.0)	(3.0)	4.7	7.8	9.6
MH0	18.0	16.5	19.0	19.0	20.0	1.0 to 1.3	6.5	(2.0)	(4.0)	4.7	8.8	9.6
MN0	18.0	21.5	19.0	19.0	20.0	1.0 to 1.3	6.5	(2.0)	(4.0)	4.7	8.8	9.6

() : Ref.

TAPING SPECIFICATIONS
RADIAL LEAD TYPE (TAPING)



◆ DIMENSION [mm]

Fig.1

Taping Code : TA, TC
φD=φ4 to 8

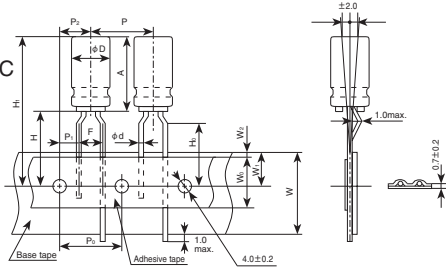

Fig.2

Taping Code : TD
φD=φ5
φD×L=φ4×7

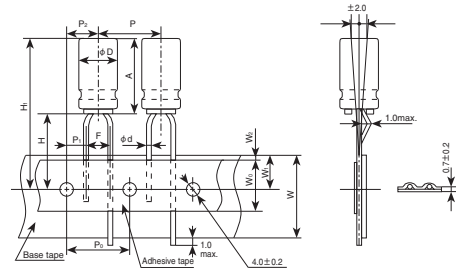

Fig.3

Taping Code : TD
φD=φ6.3 to 12.5

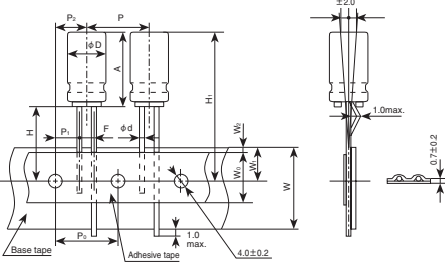
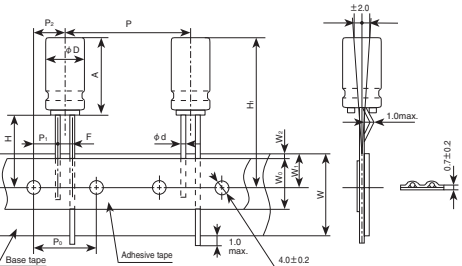

Fig.4

Taping Code : TE
φD=φ12.5



Code	Taping Code	Case size		φd	P	P ₀	P ₁	P ₂	F	W	W ₀	W ₁	W ₂	H	H ₀	H ₁	Fig.
		φD	A														
tol.		—	—	±0.05	±1.0	±0.2	±0.7	±1.0	+0.8 -0.2	±0.5	min.	±0.5	max.	±0.75	±0.5		
Nominal	TA	4	5	0.45	12.7	12.7	5.1 3.85	6.35	2.5 5	18.0	6.0	9.0	1.5	17.5	16.0	H ₁ =H+A Check insertion machine specs.	1
	TC		7	0.45	12.7	12.7	5.1 3.85	6.35	2.5 5	18.0	6.0	9.0	1.5	18.5 ^{*1} 17.5	16.0		2
	TD		11.5	0.45	12.7	12.7	5.1 3.85	6.35	2.5 5	18.0	10.0	9.0	1.5	17.5	16.0		1
	TC																
	TD	5	5 to 7	0.45	12.7	12.7	5.1 3.85	6.35	2.5 5	18.0	6.0	9.0	1.5	18.5 17.5	— 16.0		2
	TC		9 to 15	0.5	12.7	12.7	5.1 3.85	6.35	2.5 5	18.0	10.0	9.0	1.5	18.5 16.0	—		1
	TD	6.3	5 to 7	0.45	12.7	12.7	5.1 3.85	6.35	2.5 5	18.0	6.0	9.0	1.5	17.5 16.0	—		3
	TC		9 to 15	0.5	12.7	12.7	5.1 3.85	6.35	2.5 5	18.0	10.0	9.0	1.5	18.5 16.0	—		1
	TD	8	5	0.45	12.7	12.7	5.1 3.85	6.35	2.5 5	18.0	6.0	9.0	1.5	17.5 16.0	—		3
	TC		7	0.45	12.7	12.7	3.85	6.35	5	18.0	6.0	9.0	1.5	17.5	16.0		1
	TD	9 to 20	9 to 20	0.6	12.7	12.7	3.85	6.35	3.5 5	18.0	10.0	9.0	1.5	20.0 16.0	—		1
	TC																
tol.		±0.5	max.	±0.05	±1.0	±0.3	±0.7	±1.3	+0.8 -0.2	±0.5	min.	±0.5	max.	+2.0 -0	—		
Nominal	TD	10	21	0.6	12.7	12.7	3.85	6.35	5	18.0	12.5	9.0	1.5	18.0	—		3
	TD	12.5	26	0.6	15 ^{*2}	15	5.0	7.5	5	18.0	12.5	9.0	1.5	18.0	—		3
	TE			0.6	25.4	12.7	3.85	6.35	5	18.0	12.5	9.0	1.5	18.0	—		4

* 1 : For φ4×7 (A=7, F=25), shall be 18.5^{-0.5/+0.75} (Taping code : TD) at Fig.2.

* 2 : P=15 taping is not standard. Use P=25.4 taping.

TAPING CODE

Example

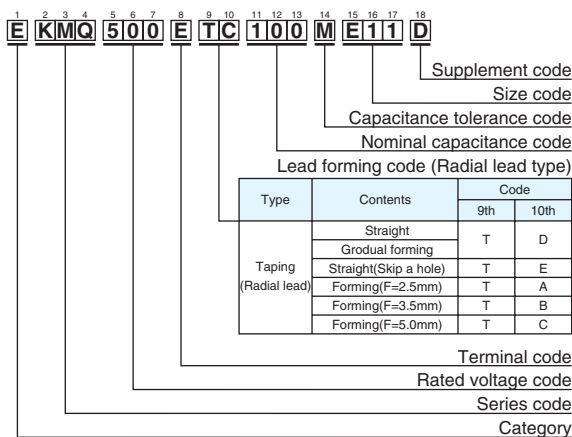

QUANTITY PER AMMO PACK

Ammo pack box

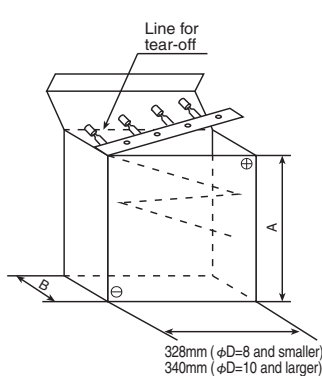

Typical example

Case size φD × L (mm)	A (mm)	B (mm)	Quantity (pcs.)	
φ4	L=5 & 7mm	183	42	2,000
	L=11.5mm	183	51	
φ5	L=5 & 7mm	232	42	2,000
	L=9 to 15mm	232	51	
φ6.3	L=17mm	235	60	2,000
	L=5 & 7mm	282	42	
φ8	L=9 to 15mm	284	51	1,000
	L=17mm	284	55	
φ10	L=5 & 7mm	308	56	800(500)*
	L=9 to 15mm	308	62	
	L=21 to 25mm	308	67	
	L=26 to 30mm	308	71	
φ12.5	L=≤16mm	308	62	500
	L=17 to 25mm	308	67	

*Minimum order quantity for PSG/PSK/PSF/PSE/PSC/PSA/PS series

RADIAL LEAD TYPE (CUT/FORMED LEAD)

The following lead configurations are available. When ordering, please indicate the type of lead configurations by using the appropriate supplement code, such as C5, FC, MC or RC in the product part number.

Terminal type	Size	Terminal type	Size
<p>●Lead code : FC (Forming Cut type)</p>	$\phi D=5$ to 8	<p>●Lead code : C5 (Cutting type)</p> <p>Dimension (C)</p> <ul style="list-style-type: none"> • $\phi D=4$ to 8: $C=5.0 \pm 0.5$ (Second standard $C=3.5 \pm 0.5$) • $\phi D=10$ to 18: $C=5.0 \pm 1.0$ (Second standard $C=3.5 \pm 0.5$) 	$\phi D=4$ to 18
<p>●Lead code : FM (Snap-in type)</p>	$\phi D=5$ to 8	<p>●Lead code : MC (Snap-in type)</p>	$\phi D=10$ to 18
<p>●Lead code : BC (Horizontal type)</p> <p>Dimension (P)</p> <ul style="list-style-type: none"> • $\phi 10, \phi 12.5$: $P=5.0 \pm 0.5$ • $\phi 14.5, \phi 16, \phi 18$: $P=7.5 \pm 0.5$ 	$\phi D=10$ to 18	<p>●Lead code : RC (Snap-in type)</p>	$\phi D=20$ to 22

* Please consult with us the other terminal forming.

◆ DIMENSION (P)

[mm]

Lead forming Size	Cutting type		Snap-in type	
	FC	C5	FM	MC
$\phi 4$	—	1.5	—	—
$\phi 5$	5.0	2.0	5.0	—
$\phi 6.3$	5.0	2.5	5.0	—
$\phi 8$	5L	2.5	5.0	—
	7L min.	3.5	5.0	—
$\phi 10$	—	5.0	—	5.0
$\phi 12.5$	—	5.0	—	5.0
$\phi 14.5$	—	7.5	—	7.5
$\phi 16$	—	7.5	—	7.5
$\phi 18$	—	7.5	—	7.5

* Please refer to dimensions of each series for lead-wire diameter (ϕd).

MINIMUM ORDER QUANTITY

Please order by minimum order quantity.

◆ SURFACE MOUNT

● Vertical



Series	Size code	Quantity (pcs)		
		Taping	Tray (pcs/box)	
Alchip™ MVA/MVE/MZJ MZA/MVY/MZF MZE/MZK/MLA MLF/MLE/MLK MVL/MVJ/MVH MHB/MHJ/MKB MV-BP/MVK-BP	D55, D60, D61	2,000	—	
	D73	1,500	—	
	E55, E60, E61, E73	1,000	—	
	F46, F55, F60, F61, F73	1,000	—	
	F80, H80	900	—	
	F90	800	—	
	H63, H70	1,000	—	
	HA0	500	—	
	HC0	400	—	
	J80, JA0	500	—	
	JC0	400	—	
	NPCAP™ PXK/PXS/PXF PXE/PXA/PXH	KE0	200	600
		KG5	150	600
		LH0	125	400
LN0		75	400	
MH0		125	300	
MN0		75	300	

◆ RADIAL



Size	Quantity (pcs)	
	Bagged*1	Taping
φ4	200	2,000
φ5	200	2,000
φ6.3	200 (200)*2	2,000 (2,000)*2
φ8	200 (100)*2	1,000 (1,000)*2
φ10	Height ≤ 25mm	200 (100)*2
	Height ≥ 30mm	200
φ12.5	100	500
φ14.5	50	250
φ16	50	250
φ18	50	250

*1 Standard bagged quantity.

*2 Minimum order quantity for PSG/PSK/PSF/PSE/PSC/PSA/ PS series.

◆ SNAP-IN

200 pieces



AVAILABLE TERMINALS FOR SNAP-IN AND SCREW-MOUNT TYPE

- We can make the following terminal type on custom design.
- There is a restriction for specification of product, please consult with us when the product is required.
- Please consult with us about terminal type other than those following listed.

Snap-in type

[mm]

<p>Terminal, Dummy code : VNN</p> <p>D=φ22 to φ35</p>	<p>Terminal, Dummy code : LIN</p> <p>D=φ30 to φ40</p>
<p>Terminal, Dummy code : VRD</p> <p>D=φ35, φ40</p> <p>B : Positive, A, C : Dummy</p>	<p>Terminal, Dummy code : VND</p> <p>D=φ35, φ40</p> <p>B : Positive, A, C : Dummy</p>
<p>Terminal, Dummy code : LIS</p> <p>D=φ50</p> <p>A : Dummy</p>	<p>Horizontal mounting Terminal, Dummy code : LCN</p> <p>D=φ20×30 to 50L, φ22×30 to 50L</p>

*1 Negative terminal : Mesh marking

*2 Use the dummy terminals for mechanical support only.

The dummy terminals must not be connected to any circuit trace on PC board, be sure to electrically isolate from the negative and the positive terminals.

Screw-mount type

[mm]

<p>Stud mounting type</p> <p>D=φ76.2</p> <p>Installation Recommendation plate thickness: 3.2mm</p> <p>Recommendation mounting hole: φ31±0.5</p> <p>Mounting screw and case are same potential as the cathode terminal. Please careful of isolation between chassis.</p>
--

Please consult with us about other size.



STANDARDIZATION

The following series are discontinued. Please use the replacements in the table.

◆CHIP TYPE REPLACEMENTS

Discontinued series	Characteristics	Replacements
MVS	85°C low profile	*
MV	85°C standard	MVA
MVK	105°C standard	MVE
MKA		
MVZ	Low impedance	MZA
MLD	Long life	MLE
MZD	Low impedance, Long life	MZE

◆LEAD TYPE REPLACEMENTS

Discontinued series	Characteristics	Replacements
SM	85°C standard	SMG
SME		
KM	105°C standard	KMG
KMC		
KME		
USM		
BSM		
SHA	95°C L=7mm	LXY/LXZ
SM-BP	85°C bi-polar	SME-BP
KM-BP	105°C bi-polar	KME-BP
SRC	85°C low profile	SRG
SXC	Low impedance	KY/LXV
LXE		
LXJ		
SXE		
KMF(6.3 to 100V _{dc})	Low impedance	LXY
LXF		
KMY	Long life	KY
LXA	Long life	KY/LXY
GXD	High heat resistance	GXE
GHA	150°C high heat resistance	*
KMF(160 to 450V _{dc})	High ripple current	KXG
KMX	Long life	
KRF	105°C large radial	KMG
KRL	105°C low leakage current	*

◆SCREW-MOUNT TERMINAL REPLACEMENTS

Discontinued series	Characteristics	Replacements
KME	High reliability	KMH
LWY	105°C long life	LXA/LXR

* Please contact us.

Already been discontinued products are not listed in this catalog,

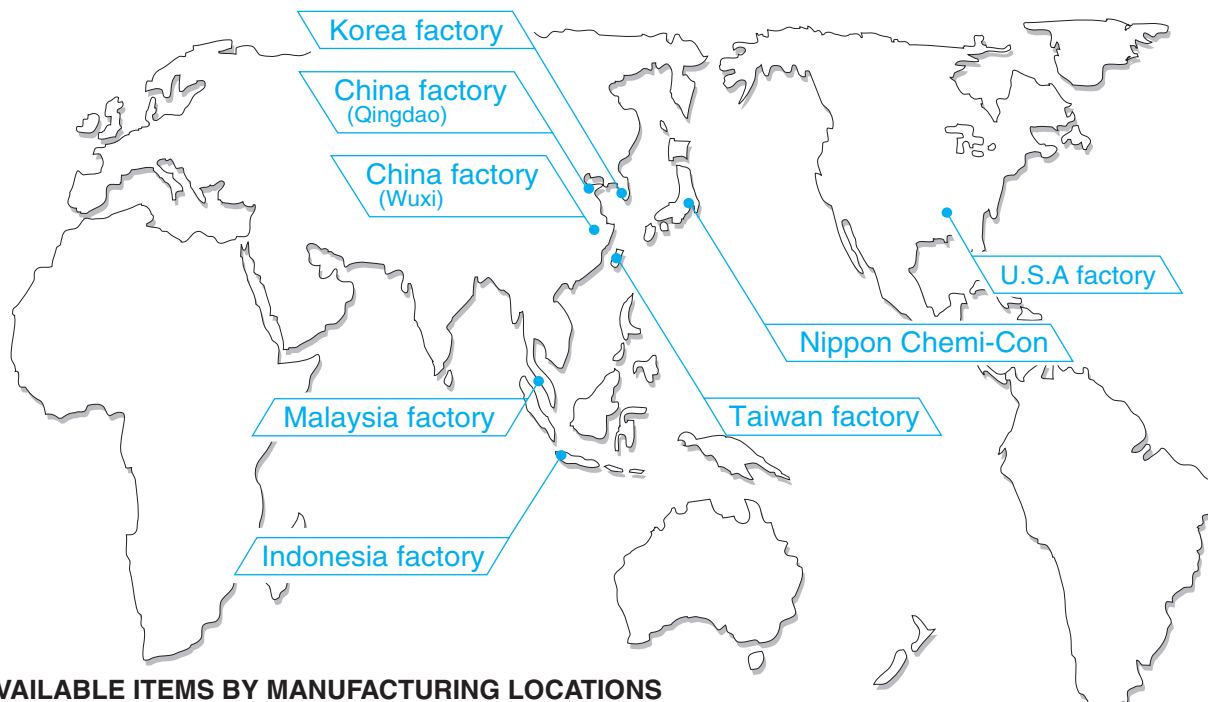

◆ AVAILABLE ITEMS BY MANUFACTURING LOCATIONS

Classification	Series	Korea factory	China factory (Qingdao)	China factory (Wuxi)	Indonesia factory	Taiwan factory	Malaysia factory	U.S.A. factory
Conductive Polymer Electrolyte Type	PSA					●		
	PSC					●		
	PSE					●		
	PSF					●		
SMD	MVA	●		●	●			
	MVE	●		●	●			
	MVY			●	●			
Low Profile	SRM				●			
	SRE				●			
	SRA				●			
	KMA				●			
	SRG				●			
General purpose	SMG	●	●	●	●	●		
	KMG	●	●	●	●	●		
	SMQ			●	●			
	KMQ			●	●	●		
Bi-polar	SME-BP	●	●		●			
	KME-BP	●	●		●			
Low impedance, High ripple	LXZ			●	●			
	LXV			●	●	●		
	KY	●	●	●	●	●		
	KZE	●	●	●	●	●		
	KZH			●	●	●		
	KZM			●	●	●		
	KXG			●		●		
Snap-in	SMQ						●	●
	KMQ						●	●
	SMM						●	●
	KMM						●	●
Screw-mount Terminal	KMH							●
	RWE			●				●
	RWF							●
	RWL							●
	LXA							●

Please be sure to contact us before ordering as our product range is continuously improved and the product you require may have been superseded.

RECOMMENDED SOLDERING CONDITIONS FOR NPCAP™

◆ SURFACE MOUNT TYPE

The following conditions are recommended for air or infrared reflow soldering P XK/PXS/PXF/PXE/PXA/PXH series onto a glass epoxy circuit board of 90×50×0.8mm (with resist) by cream solder. The temperatures shown are the surface temperature values on the top of the can and temperature of capacitor terminal.

Reflow should be performed twice or less.

Please ensure that the capacitor became cold enough to the room temperature (5 to 35°C) before the second reflow.

● Recommended soldering heat conditions

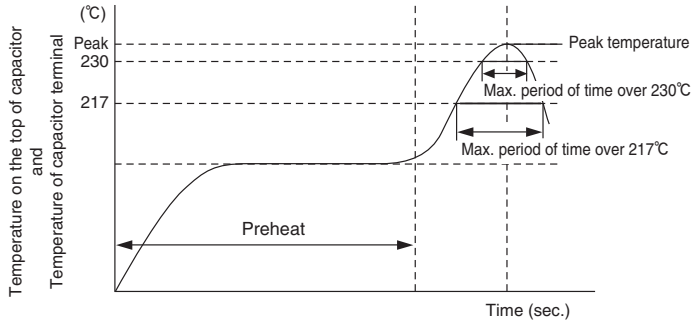

Voltage range (V _{dc})	Preheat	Time maintained above 217°C	Time maintained above 230°C	Peak temp.	Reflow number
2.5 to 16V	150 to 180°C 120 sec.max.	50 sec.max.	40 sec.max.	260°Cmax.	1-cycle only
				250°Cmax.	2-cycle allowed
20 to 25V		50 sec.max. (40 sec.max.)	40 sec.max. (30 sec.max.)	250°Cmax. (240°Cmax.)	1-cycle only
		40 sec.max.	30 sec.max.		2-cycle allowed

() : Applies for 20V 82μF(J80) and 25V 39μF(J80)

● Recommended Solder Land on PC Board

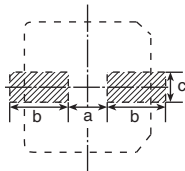

Solder land on PC board

Size code	a	b	c
D55	1.0	2.6	1.6
E60,E61	1.4	3.0	1.6
F46, F55 F60, F61, F80	1.9	3.5	1.6
H70, H80, HA0, HC0	3.1	4.2	2.2
J80, JA0, JC0	4.5	4.4	2.2

◆ RADIAL LEAD TYPE

● Recommended soldering heat conditions

Preheat : 150°C 120 seconds max.

Flow soldering : 260+5°C max. 10+1 seconds max.

◆ PRECAUTIONS FOR USERS

Soldering method

SMD type have no capability to withstand such dip or wave soldering as totally immersing components into a solder bath.

Reflow soldering

Reflow the capacitors within Recommended Reflow Soldering Conditions. Verify there is no temperature stress to the capacitors because the following differences might degrade capacitors electrically and mechanically. Please consult with us if other reflow conditions are employed.

1. Location of components : Temperature increases at the edge of PC board more than the center.
2. Population of PC board : The lower the component population is, the more temperature rises.
3. Material of PC board : A ceramic-made board needs more heat than a glass epoxy-made board. The heat increase may cause damage to the capacitors.
4. Thickness of PC board : A thicker board needs more heat than a thinner board. The heat may damage the capacitors.
5. Size of PC board : A larger board needs more heat than a smaller board. The heat may damage the capacitors.
6. Solder thickness
If very thin cream solder paste is to be used for SMD types, please consult with us.
7. Location of infrared ray lamps : IR reflow as well as hot plate reflow heats only on the reverse side of the PC board to lessen heat stress to the capacitors.
8. Case leakage current will increase (~mA) after the reflow process, the leakage current which rose gradually decreases when voltage is applied.
9. Vapor phase soldering (VPS) is not used.

Rework of soldering

Use a soldering iron for rework. Do not exceed an iron tip temperature of 380±10°C and an exposure time of 3±0.5 seconds.

Mechanical stress

Do not grab the capacitors to lift the PC board and give stress to the capacitor. Avoid bending the PC board. This may damage the capacitors.

Cleaning assembly board

Immediately after solvent cleaning, remove residual solvent with an air knife for at least 10 minutes. If the solvent is insufficiently dry, the capacitors may corrode.

Coating on assembly board

1. Before curing coating material, remove the cleaning solvents from the assembly board.
2. Before conformal coating, a chloride free pre-coat material is recommended to decrease the stress on the capacitors.

Molding with resin

Internal chemical reaction gradually produces gas in the capacitor; increasing internal pressure. If the end seal of the capacitor is completely covered by resin the gas will be unable to escape causing a potentially dangerous situation. The chlorine in resin will penetrate the end seal, reach the element, and damage of the capacitor.

Glue

The followings are requirements for glue.

1. A low curing temperature over a short period of time
2. Strong adhesion and heat resistance after curing
3. Long shelf life
4. No corrosion

Others

Refer to PRECAUTIONS AND GUIDELINES(Conductive Polymer).

RECOMMENDED REFLOW SOLDERING CONDITIONS

Alchip™ MVA/MVE/MZJ/MZA/MVY/MZF/MZE/MZK/MLA/MLF/MLK/MLV/MVJ/MVH/MHB/MHJ/MKB/MV-BP/MVK-BP

The following conditions are recommended for air convection and infrared reflow soldering on the SMD products on to a glass epoxy circuit boards by cream solder. The dimensions of the glass epoxy boards with resist are 90×50×0.8mm for D55 to KG5 case code SMD capacitors and 180×90×0.8mm for LH0 to MNO case codes SMD capacitors.

The temperatures shown are the surface temperature values on the top of the can and on the capacitor terminals.

Reflow should be performed twice or less.

Please ensure that the capacitor became cold enough to the room temperature (5 to 35°C) before the second reflow.

Consult with us when performing reflow profile in IPC / JEDEC (J-STD-020)

●Recommended soldering heat conditions (Except for Conductive Polymer Aluminum Solid Capacitors)

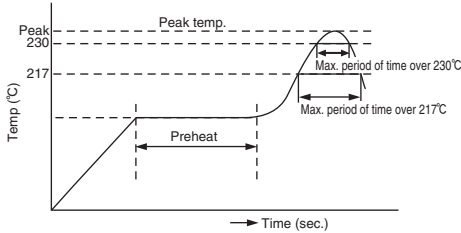

SMD type	Size code	Voltage range (V _{dc})	Preheat	Time maintained above 217°C	Time maintained above 230°C	Peak temp.	Reflow number
Vertical	D55 to F90	4 to 63V (Except 63V for MVH)	150 to 180°C 120sec. max.	90sec. max.	60sec. max.	260°Cmax.	2 times or less
		63V(MVH), 80V		60sec. max.	40sec. max.	250°Cmax.	2 times or less
	4 to 50V	60sec. max.		30sec. max.	245°Cmax.	2 times or less	
	63 to 100, 400V	30sec. max.		20sec. max.	240°Cmax.	2 times or less	
KE0 to MNO	6.3 to 50V	30sec. max.	20sec. max.	240°Cmax.	2 times or less		
	63 to 450V	20sec. max.	—	230°Cmax.	2 times or less		

●Recommended Solder Land on PC Board

Series : MVA/MVE/MZJ/MZA/MVY/MZF/MZE/MZK/MLA/MLF/MLK/MLV/MVJ/MVH/MHB/MHJ/MKB/MV-BP/MVK-BP

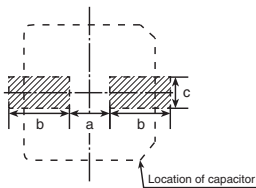

: Solder land on PC board

Size code	Terminal code : A			Terminal code : G		
	a	b	c	a	b	c
D55, D60, D61, D73	1.0	2.6	1.6			
E55, E60, E61, E73	1.4	3.0	1.6			
F55, F60, F61, F73, F80, F90	1.9	3.5	1.6			
H63	2.3	4.5	1.6			
HA0	3.1	4.2	2.2	3.1	4.2	3.5
JA0	4.5	4.4	2.2	4.5	4.4	3.5
KE0, KG5	4.0	5.7	2.5	3.4	6.3	9.3
LH0, LNO	6.0	6.9	2.5	4.7	7.8	9.6
MH0, MNO	6.0	7.9	2.5	4.7	8.8	9.6

◆PRECAUTIONS FOR USERS

Soldering method

The capacitors of Alchip-series have no capability to withstand such dip or wave soldering as totally immerses components into a solder bath.

Reflow soldering

Reflow the capacitors within recommended reflow soldering conditions. Verify there is no temperature stress to the capacitors because the following differences might degrade capacitors electrically and mechanically. Please consult us if other reflow conditions are employed.

1. Location of components : Temperature increases at the edge of PC board more than the center.
2. Population of PC board : The lower the component population is, the more temperature rises.
3. Material of PC board : A ceramic made board needs more heat than a glass epoxy made board. The heat increase may cause damage to the capacitors.
4. Thickness of PC board : A thicker board needs more heat than a thinner board. The heat increase may damage the capacitors.
5. Size of PC board : A larger board needs more heat than a smaller board. The heat increase may damage the capacitors.
6. Solder thickness
If very thin cream solder paste is to be used for SMD types, please consult with us.
7. Location of infrared ray lamps : IR reflow as well as hot plate reflow heats only on the reverse side of the PC board to lessen heat stress to the capacitors.
8. Vapor phase soldering (VPS) is not used.

Rework of soldering

Use a soldering iron for rework. Do not exceed an iron tip temperature of 380±10°C and an exposure time of 3±0.5 seconds.

Mechanical stress

Do not use the capacitors for lifting the PC board and give stress to the capacitor. Avoid bending the PC board. This may damage the capacitors.

Cleaning assembly board

Immediately after solvent cleaning, remove residual solvent with an air knife for at least 10 minutes. If the solvent is insufficiently dry, the capacitors may corrode.

Coating on assembly board

1. Before curing coating material, remove the cleaning solvents from the assembly board.
2. Before conformal coating, a chloride free pre-coat material is recommended to decrease the stress on the capacitors.

Molding with resin

Internal chemical reaction gradually produces gas in the capacitor; then, increasing internal pressure. If the end seal of the capacitor is completely covered by resin the gas will be unable to escape causing a potentially dangerous situation. The chlorine contained resin will penetrate into the end seal, reach the inside element, and cause damage of the capacitor.

Others

Refer to PRECAUTIONS AND GUIDELINES.

The NPCAP™ is a Conductive Polymer Solid Aluminum Capacitor that uses highly conductive polymer electrolytic material. Please read the following in order to get the most out of your NPCAP™ capacitor.
For aluminum electrolytic capacitors, please refer to PRECAUTIONS AND GUIDELINES.

1 Designing Device Circuits

1) Types of Circuits Where NPCAP™ Capacitors are Not to be Used

The leakage current in conductive polymer solid aluminum capacitors (hereafter called capacitors) may vary depending on thermal stresses during soldering. Avoid the use of capacitors in the following types of circuits:

- ① High-impedance circuits that are to sustain voltages.
- ② Coupling circuits
- ③ Time constant circuits

Because the capacitance varies depending on the environment the capacitors are used in, there is a possibility that the capacitor can affect a time constant circuit where sensitivity to variation in capacitance is required.

- ④ Other circuits that are significantly affected by leakage current

2) Circuit Design

Verify the following before designing the circuit:

- ① The electrical characteristics of the capacitor will vary depending on differences in temperature and frequency. You had better design after verifying the scope of these factors.
- ② When connecting two or more capacitors in parallel, ensure that the design takes current balancing into account.
- ③ When two or more capacitors are connected in series, variability in applied voltage may cause over-voltage conditions. Contact Nippon Chemi-Con before using capacitors connected in series.
- ④ Avoid putting heat generating parts either around the capacitor or on the reverse of the circuit board.

3) Use in High Reliable and Critical Applications

Consult with Nippon Chemi-Con before using these capacitors in applications involving human life: Aviation/space equipment, Nuclear power equipment, Medical equipment and Automotive equipment, or in applications where capacitor failure could have a major impact.

4) Polarity

The NPCAP™ is a polarized solid aluminum electrolytic capacitor. Do not apply either reverse voltages or AC voltages to the polarized capacitors, using reversed polarity may cause a short circuit. Refer to the catalog, product specifications or capacitor body to confirm the polarity prior to use.

5) Operating Voltage

Do not apply a greater than rated voltage, if a voltage greater than the rated voltage is suddenly applied the leakage current increases causing shorting. The peak voltage of superimposed AC voltages (ripple voltages) on DC voltages must not exceed the full rated voltage. While there are specifications for surge voltages exceeding the rated voltage, usage conditions apply, and continued operation for extended periods of time under such conditions cannot be guaranteed.

6) Ripple Current

Do not apply currents in excess of the rated ripple current. The superimposition of a large ripple current increases the rate of heating within the capacitor. When excessive ripple current is imposed the internal temperature increases which can shorten life and shorting may occur.

7) Operating Temperature

Use within the stated category temperature range, if used outside this range, characteristics can deteriorate potentially leading to problems.

8) Charging and Discharging the Capacitor

Do not use the NPCAP™ capacitor in circuits where the capacitor is repetitively charged and discharged rapidly. Repetitively charging and discharging the capacitor rapidly may reduce the capacitance or may cause damage due to internal heating. Use of a protective circuit to ensure reliability is recommended when rush currents exceed 20A.

9) Leakage current

The leakage current may increase when the capacitors are subjected to the conditions below. After that, however, the leakage current will gradually decrease by self-healing action of the dielectric oxide layer when the capacitors are applied with a voltage less than the rated voltage within the Category Temperature range. As the voltage is closer to the rated voltage and the temperature is closer to the upper limit of Category Temperature range, the leakage current decreases faster.

The leakage current will increase by the following factors,

- ① Soldering
- ② Testing of high temperature exposure with no voltage applied, high temperature/humidity storage, temperature cycles, etc.

10) Failures and Service Life

Based on the JIS C 5003 Standard, the failure rate for NPCAP™ capacitors (with a 60% reliability standard) is as follows:

0.5%/1,000 hours (applied the rate voltage at the upper limit of Category Temperature range)

(1) Failure Modes

- ① The principal failure mode is wear-out failure, that is, capacitance decreases and ESR increases, and eventually the capacitors become open circuit failure. In addition, short circuit failure may happen with over-voltage and excessive current applied to the capacitors.
- ② The failure rate would be reduced by reducing ambient temperatures, ripple current and applying voltage.
- ③ If the short-circuited capacitor, which may be caused by over-voltages higher than the rated voltage or other conditions, has a large amount of current passed through, the aluminum can of the capacitor bulges and might be expelled with odor gas emitted.
- ④ The product contains flammable materials. If the short causes a spark it may ignite.

Please be careful when installing the product, its position and the layout design.

- Increase safety by using in conjunction with a protective circuit or protective equipment.
- Install measures such as redundant circuits so that the failure of a part of the equipment will not cause unstable operation.

(2) Service Life

NPCAP™ uses rubber as the sealing material, so the service life depends on the thermal integrity of this rubber. Consequently, it is recommended to use the capacitor at a lower temperature than the maximum temperature for the capacitor category.

11) Capacitor Insulation

Insulation of the capacitor's case is not guaranteed. Ensure electrical insulation between the capacitor case, negative electrode, positive electrode and circuit pattern.

12) Capacitor Usage Environment

Do not use/expose capacitors to the following conditions.

- ① Oil, water, salty water, take care to avoid storage in damp locations.
- ② Direct sunlight
- ③ Toxic gases such as hydrogen, sulfide, sulfurous acids, nitrous acids, chlorine and chlorine compounds, bromine and bromine compounds, ammonia, etc.
- ④ Ozone, ultraviolet rays and radiation.
- ⑤ Severe vibration or mechanical shock conditions beyond the limits advised in the product specification section of the catalog.

13) Capacitor mounting

- ① For the surface mount capacitor, design the solder land on the PC board in accordance with the catalog or the product specification.
- ② For radial capacitors, design the terminal holes on the PC board to fit the terminal dimension of the capacitor.
- ③ Do not pass any circuit traces beneath the seal side of a capacitor. The trace must pass 1 to 2mm to the side of the capacitor.
- ④ Do not pass any via holes underneath a capacitor on double sided PC board
- ⑤ In designing double-sided PC boards, do not locate any copper trace under the seal side of a capacitor

2 | Installing Capacitors

1) Installing

- ① Do not reuse capacitors already assembled in equipment that have been exposed to power.
- ② The capacitor may have self charge. If this happens, discharge the capacitor through a resistor of approximately 1kΩ before use.
- ③ If capacitors are stored at a temperature of 35°C or more and more than 75%RH, the leakage current may increase. This may also occur if the capacitors are stored for a longer period than the period which is specified in the catalog or the product specification. In this case, they can be reformed by the voltage treatment through a resistor of approximately 1kΩ.
- ④ Verify the rated capacitance and voltage of the capacitors when installing.
- ⑤ Verify the polarity of the capacitors.
- ⑥ Do not use the capacitors if they have been dropped on the floor.
- ⑦ Do not deform the case of the capacitors.
- ⑧ Verify that the lead spacing of the capacitor fits the hole spacing in the PC board before installing the capacitors.
- ⑨ Do not apply any mechanical force in excess of the limits prescribed in the catalog or the product specification of the capacitors. Avoid subjecting the capacitor to strong forces, as this may break the electrode terminals, bend or deform the capacitor, or damage the packaging, and may also cause short/open circuits, increased leakage current, or damage the appearance. Also, note the capacitors may be damaged by mechanical shocks caused by cut the lead wire, the vacuum/insertion head, component checker or centering operation of an automatic mounting or insertion machine.

2) Heat Resistance during Soldering

Ensure that the soldering conditions meet the specifications recommended by Nippon Chemi-Con. Note that the leakage current may increase or capacitance may decrease due to thermal stresses that occur during soldering, etc. Furthermore, the leakage current which rose gradually decreases, when voltage is applied at below the category upper limit temperature. Additionally the self repairing action is faster when voltage near the rated voltage rather than at a higher voltage is applied at below the category's upper temperature limit.

- ① Verify the following before using a soldering iron:

- That the soldering conditions (temperature and time) are within the ranges specified in the catalog or product specifications.
 - That the tip of the soldering iron does not come into contact with the capacitor itself.
- ② Verify the following when flow soldering:
 - Do not dip the body of a capacitor into the solder bath only dip the terminals in. The soldering must be done on the reverse side of PC board.
 - Soldering conditions (preheat, solder temperature and dipping time) should be within the limits prescribed in the catalog or the product specifications.
 - Do not apply flux to any part of capacitors other than their terminals.
 - Make sure the capacitors do not come into contact with any other components while soldering.
 - ③ Verify the following when reflow soldering:
 - Soldering conditions (preheat, solder temperature and soldering time) should be within the limits prescribed in the catalogs or the product specification.
 - The heat level should be appropriate. (Note that the thermal stress on the capacitor varies depending on the type and position of the heater in the reflow oven, and the color and material of the capacitor.)
 - Vapor phase soldering (VPS) is not used.
 - Except for the surface mount type, reflow soldering must not be used for the capacitors.
 - ④ Do not reuse a capacitor that has already been soldered to PC board and then removed. When using a new capacitor in the same location, remove the flux, etc. first, and then use a soldering iron to solder on the new capacitor in accordance with the specifications.
 - ⑤ Confirm before running into soldering that the capacitors are SMD for reflow soldering.

3) Handling After Soldering

Do not apply any mechanical stress to the capacitor after soldering onto the PC board.

- ① Do not lean or twist the body of the capacitor after soldering the capacitors onto the PC board.
- ② Do not use the capacitors for lifting or carrying the assembly board.
- ③ Do not hit or poke the capacitor after soldering to PC board. When stacking the assembly board, be careful that other components do not touch the aluminum electrolytic capacitors.
- ④ Do not drop the assembled board.

4) Cleaning PC boards

- ① Do not wash capacitors by using the following cleaning agents. Solvent resistant capacitors are only suitable for washing using the cleaning conditions prescribed in the catalog or the product specification. In particular, ultrasonic cleaning will accelerate damage to capacitors.
 - Halogenated solvents; cause capacitors to fail due to corrosion.
 - Alkali system solvents; corrode (dissolve) an aluminum case.
 - Petroleum system solvents; cause the rubber seal material to deteriorate.
 - Xylene; causes the rubber seal material to deteriorate.
 - Acetone; erases the markings.
 CFC alternatives or the other cleaners above; please consult with us
- ② Verify the following points when washing capacitors.
 - Monitor conductivity, pH, specific gravity and the water content of cleaning agents. Contamination adversely affects these characteristics.
 - Be sure not to expose the capacitors under solvent rich conditions or keep capacitors inside a closed container. In addition, please dry the solvent sufficiently on the PC board and the capacitor with an air knife (temperature

should be less than the maximum rated category temperature of the capacitor) for 10 minutes. Aluminum electrolytic capacitors can be characteristically and catastrophically damaged by halogen ions, particularly by chlorine ions, though the degree of the damage mainly depends upon the characteristics of the electrolyte and rubber seal material. When halogen ions come into contact with the capacitors, the foil corrodes when a voltage is applied. This corrosion causes an extremely high leakage current which results venting and an open circuit.

If the new types of cleaning agents mentioned below are used, the following are recommended as cleaning conditions for some of new cleaning agents.

-Higher alcohol cleaning agents

Pine Alpha ST-100S (Arakawa Chemical)
Clean Through 750 H, 750K, 750L, and 710M (Kao)
Technocare FRW-14 through 17 (Momentive performance material)
Cleaning Conditions:

Using these cleaning agents, capacitors are capable of withstanding immersion or ultrasonic cleaning for 10 minutes at a maximum liquid temperature of 60°C. Find optimum condition for washing, rinsing, and drying. Be sure not to rub the marking off the capacitor which can be caused by contact with other components or the PC board. Note that shower cleaning adversely affects the markings on the sleeve.

-Non-Halogenated Solvent Cleaning

AK225AES (Asahi Glass)
Cleaning Conditions:

Immersion, ultrasonic or vapor cleaning for 5 minutes. However, from an environmental point of view, these types of solvent will be banned in near future. We would recommend not using them if at all possible.

-Isopropyl Alcohol (IPA)

IPA (Isopropyl Alcohol) is one of the most acceptable cleaning agents; it is necessary to maintain a flux content in the cleaning liquid at a maximum limit of 2 Wt.%.

5) Precautions for using adhesives and coating materials

- ① Do not use any adhesive and coating materials containing halogenated solvent.
- ② Verify the following before using adhesive and coating material.
 - Remove flux and dust left over between the rubber seal and the PC board before applying adhesive or coating materials to the capacitor.
 - Dry and remove any residual cleaning agents before applying adhesive and coating materials to the capacitors. Do not cover over the whole surface of the rubber seal with the adhesive or coating materials.
 - For permissible heat conditions for curing adhesives or coating materials, please consult with us.
 - Covering over the whole surface of the capacitor rubber seal with resin may result in a hazardous condition because the inside pressure cannot be completely released. Also, a large amount of halogen ions in resins will cause the capacitors to fail because the halogen ions penetrate into the rubber seal and the inside of the capacitor.
 - Some coating materials, it cannot be implemented to the capacitor.
Please note change on the surface might be caused according to the kind of solvents used for mounting adhesives and coating agents.

6) Fumigation

In many cases when exporting or importing electronic devices, such as capacitors, wooden packaging is used. In order to control insects it may become necessary to fumigate the shipment.

Precautions during “Fumigation” using halogenated chemical such as Methyl Bromide must be taken. Halogen gas can penetrate packaging materials such as cardboard boxes and vinyl bags. Penetration of the halogenated gas can cause corrosion of Electrolytic capacitors. Nippon Chemi-Con gives consideration to the packaging materials not to require the Fumigation. Verify whether the assembled PC board, products and capacitors themselves are subjected to Fumigation during their transportation or not.

3) The Operation of Devices

- 1) Do not touch the capacitor terminals directly.
- 2) Do not short-circuit the terminal of a capacitor by letting it come into contact with any conductive object. Also, do not spill electric-conductive liquid such as acid or alkaline solution over the capacitor.
- 3) Do not use capacitors in circumstances where they would be subject to exposure to the following materials
 - Oil, water, salty water or damp location.
 - Direct sunlight.
 - Ozone, ultraviolet rays or radiation.
 - Toxic gases such as hydrogen sulfide, sulfuric acid, nitrous acid, chlorine or its compounds, and ammonium.
 - Severe vibration or mechanical shock conditions beyond the limits prescribed in the catalog or product specification.

4) Maintenance Inspection

- 1) Make periodic inspections of capacitors that have been used in industrial applications. Before inspection, turn off the power supply and carefully discharge the electricity in the capacitors. Verify the polarity when measuring the capacitors with a volt-ohm meter. Do not apply any mechanical stress to the terminals of the capacitors.
- 2) The following items should be checked during the periodic inspections.
 - ① Significant damage in appearance
 - ② Electrical characteristics: leakage current, capacitance, $\tan \delta$ and other characteristics prescribed in the catalog or product specification.
 We recommend replacing the capacitors if the parts are out of specification.

5) Contingencies

- 1) If gas has vented from the capacitor during use, there is a short circuit and burning, or the capacitor discharges an odor or smoke, turn off the main power supply to the equipment or unplug the power cord.
- 2) If there is a problem with the capacitor or a fire breaks out, the capacitor may produce a burning gas or reactive gas from the outer resin, etc. If this happens, keep your hands and face away from the gas. If vented gas is inhaled or comes into contact with your eyes, flush your eyes immediately with water and/or gargle. If vented gas comes into contact with the skin, wash the affected area thoroughly with soap and water.

6) Storage

We recommend the following conditions for storage.

- 1) Store capacitors in a cool, dry place. Store at a temperature between 5 and 35°C, with a humidity of 75% or less.

(table-1)

	Before the bag is opened	After the bag is opened
SMD	Within 3 years after manufacturing	Within 6 months after the bag is opened
Radial	Within 3 years after manufacturing	—

SMD products are sealed in a special laminated aluminum bag. Use all capacitors once the bag is opened. Return unused capacitors to the bag, and seal it with a zipper. Please refer to (Table -1) for storage conditions. Be sure to follow our recommendations for reflow soldering.

- 2) Store the capacitors in a location free from direct contact with water, salt water, and oil.
- 3) Store in a location where the capacitor is not exposed to toxic gas, such as hydrogen sulfide, sulfurous acid, nitrous acid, chlorine or chlorine compounds, bromine or other halogen gases, methyl bromide or other halogen compounds, ammonia, or similar.
- 4) Store in a location where the capacitor is not exposed to ozone, ultraviolet radiation, or other radiation.
- 5) It is recommended to store capacitors in their original packaging wherever possible.
- 6) The JEDEC J-STD-020 (Rev. C) standard does not apply.

7 Disposal

Please consult with a local industrial waste disposal specialist when disposing of aluminum electrolytic capacitors.

8 Catalogs

Specifications in the catalogs may be subject to change without notice. For more details of precautions and guidelines for aluminum electrolytic capacitors, please refer to Engineering Bulletin No. 634A.

Catalog data are typical. This value does not guarantee the performance.

9 Regarding compliance for EU REACH Regulation

- 1) According to the content of REACH handbook (Guidance on requirements for substances in articles which is published on May 2008), our electronic components are "articles without any intended release". Therefore they are not applicable for "Registration" for EU REACH Regulation Article 7 (1).

Reference: Electrolytic Condenser Investigation Society

"Study of REACH Regulation in EU about Electrolytic Capacitor"
(publicized on 13 March 2008)

- 2) Nippon Chemi-Con develops the products without substance of very high concern(SVHC).DEHP(CASNo.117-81-7) was contained as some covering material, Nippon Chemi-Con abolished use of DEHP totally at June, 2011.

For Conductive Polymer Aluminum Solid Electrolytic Capacitors, see Precautions and Guidelines (Conductive Polymer Aluminum Solid Electrolytic Capacitors)

1) Device circuits design considerations

1) Confirm installation and operating requirements for capacitors, then use them within the performance limits prescribed in this catalog or product specifications.

2) Polarity

Aluminum electrolytic capacitors are polarized. Never apply a reverse voltage or AC voltage. Connecting with wrong polarity will short-circuit or damage the capacitor with the pressure relief vent opening early on. To identify the polarity of a capacitor, see the relevant diagram in the catalogs or product specifications, or the polarity marking on the body of the capacitor. Incidentally, the rubber end seal bungs of the radial lead type capacitors have a solder-flux gas escaping configuration, which is nothing to do with the polarity of the capacitors. For circuits where the polarity is occasionally reversed, use a bi-polar type of aluminum electrolytic capacitor. However, note that even bi-polar type capacitors must not be used for AC circuits.

3) Operating voltage

Do not apply an over-voltage that exceeds a rated voltage specified for the capacitors. The total peak value of the ripple voltage plus the DC voltage must not exceed the rated voltage of the capacitors. Although capacitors specify a surge voltage that exceeds the full rated voltage, it does not assure long-term use but limited use under specific conditions.

4) Ripple current

Do not apply an overcurrent that exceeds the rated ripple current specified for the capacitors. Excessive ripple current will increase heat production within the capacitors, causing the capacitors to be damaged as follows:

- Shorten lifetime
- Open pressure relief vent
- Short circuit

The rated ripple current is specified along with a specific ripple frequency.

Where using the capacitors at any other ripple frequency other than the specified frequency, calculate the allowable ripple current by multiplying the rated ripple current by a frequency compensation factor (Frequency Multiplier) specified for each product series.

5) Operating temperature (Category temperature)

Do not apply high temperatures that exceed the upper limit of the category temperature range specified for the capacitors. Using the capacitor at temperatures higher than the upper limit will considerably shorten the lifetime of the capacitor and make the pressure relief vent open. In other words, lowering ambient temperatures will extend the expected lifetime of the capacitors.

6) Lifetime

Select the capacitors to meet the service life requirements of a device.

7) Charging and discharging

Do not use capacitors in circuits intended for rapid charge and discharge cycle operations.

If capacitors are used in the circuits that repeat a charge and discharge with a large voltage drop or a rapid charge and discharge at a short interval cycle, capacitance will decrease and/or the capacitors will be damaged by internal heat generation.

Consult us for a heavy charge and discharge type of capacitor so that the capacitor will be designed in accordance with requirements of duty cycle of charge and discharge, the number of cycles, discharging resistance and operating temperatures.

8) Failure mode of capacitors

Non-solid aluminum electrolytic capacitors have a limited lifetime which ends in an open circuit failure mode, in general. Depending on the product type and operating conditions, the failure mode may involve in opening of the pressure relief vent.

9) Capacitor insulation

Electrically isolate the following sections of a capacitor from the negative terminal, the positive terminal and the circuit patterns.

- The outer can case of a non-solid aluminum capacitor.
- The dummy terminal of a snap-in type non-solid aluminum capacitor, which is designed for mounting stability.

10) Outer sleeve

The outer sleeve of a capacitor does not assure electrical insulation (except for screw-terminal type capacitors). It should not be used where electrical insulation is required.

11) Operating conditions

Do not use/expose capacitors to the following conditions:

- ① Direct contact with water, salt water or oil, or high condensation environment.
- ② Direct sunlight.
- ③ Toxic gases such as hydrogen sulfide, sulfurous acid, nitrous acid, chlorine and its compounds, bromine and its compounds and ammonium.
- ④ Ozone, ultraviolet rays or radiation.
- ⑤ Extreme vibration or mechanical shock that exceeds limits in the catalogs or product specifications.

12) Mounting

① Non-solid aluminum electrolytic capacitors contain paper separators and electric-conductive electrolyte that contains organic solvent as main solvent material, both of which are flammable. If the electrolyte leaks onto a printed circuit board, it can erode the device circuit pattern, may short-circuit the copper traces, smoke and burn. Make sure of designing a PC board as follows:

- Provide the appropriate hole spacing on the PC board to match the terminal spacing of a capacitor.
- Provide the following adequate clearance space over the pressure relief vent of a capacitor to avoid blocking the correct opening of the pressure relief vent.

Case diameter	Clearance
φ 8(6.3) to φ 16mm:	2mm minimum
φ 18 to φ 35mm:	3mm minimum
φ 40 mm and above:	5mm minimum

- Do not locate any wire or circuit pattern over the pressure relief vent of a capacitor.
 - If a capacitor is mounted with its pressure relief vent facing down on the PC board, provide a ventilation hole in the board beneath it to let gas escape when the vent opens.
 - Do not print any copper trace under the seal (terminal) side of a capacitor. Copper traces should be 1 mm (preferably 2mm or more) spaced apart from the side of the capacitor body.
 - Avoid locating any heat source components near capacitors or on the opposite side of the PC board under capacitors.
 - In designing a double-sided PC board, do not locate any through-hole via or unnecessary hole underneath a capacitor.
 - In designing a double-sided PC board, do not print any circuit pattern underneath a capacitor.
- ② For a screw terminal type capacitor, tightening the terminal screws and the mounting clamp should be within the maximum torque specified in the catalogs or product specifications. Do not mount a screw terminal type capacitor with the terminals facing downward. Also, if the body of a capacitor is installed horizontally such as being laid on its side, do not position the pressure relief vent downward.
- ③ For a chip type capacitor, design the land patterns of the PC board in accordance with the recommended footprint dimensions described in the catalogs or product specifications.

13) Using capacitors for significantly safety-oriented applications

Consult us about capacitors for a device application affecting human safety (①Aviation and space, ②Nuclear, ③Medical and ④Vehicle) or for any device whose failure will make an impact on society. Note that some products such as photoflash use capacitors which have been designed for specific applications cannot be used for any other application.

14) Others

Design device circuits taking into consideration the following conditions:

- ① Electrical characteristics of a capacitor depend on the temperature and frequency. In designing the device circuits, consider the change in the characteristics.
- ② If using more than one capacitor connected in parallel, design the device circuits to balance the current flow in individual capacitors.
- ③ If using more than one capacitor connected in series, connect shunting resistors in parallel with the individual capacitors to balance the voltage.

2) Installation

1) Assembling

- ① Do not try to reuse the capacitors once assembled and electrified, except only capacitors that are taken from a device for periodic inspection to measure their electrical characteristics.
- ② Capacitors may have been spontaneously recharged with time by a recovery voltage phenomenon. In this case, discharge the capacitors through a resistor of approximately 1kΩ before use.
- ③ If non-solid aluminum electrolytic capacitors have been stored at any conditions more than 35°C and 75%RH for long storage periods of time more than the limits specified in the catalogs or product specifications, they may have high leakage current. In this case, make pre-conditioning by applying the rated voltage through a resistor of approximately 1kΩ.
- ④ Confirm the rated capacitance and voltage of capacitors before installation.
- ⑤ Confirm the polarity of capacitors before installation.
- ⑥ Do not try to use the capacitors that were dropped to the floor and so forth.
- ⑦ Do not deform the can case of a capacitor.
- ⑧ Make sure that the terminal spacing of a capacitor equals the holes spacing on the PC board before installing the capacitor. For radial lead type capacitors, some standard pre-formed lead types are also available.
- ⑨ When installing a snap-in type capacitor on the PC board, insert the terminals into the holes and press the capacitor down until the body is settled flush on the surface of the PC board (without the body standing off).
- ⑩ Do not apply excessive mechanical force to capacitors more than the limits prescribed in the catalogs or product specifications. Avoid excessive mechanical force while the capacitors are in the process of vacuum-picking, placing and positioning by automatic mounting machines or cutting the lead wires by automatic insertion machines.

2) Soldering and heat resistance

- ① For soldering using a soldering iron, consider the following conditions:
 - Soldering conditions (temperature and time) should be within the limits prescribed in the catalogs or product specifications.
 - If it is necessary to pre-form the terminal spacing of a capacitor to match the hole spacing on the PC board before assembly and soldering, do not make mechanical stress reach into the body of the capacitor but only the lead wires.
 - Do not touch the body of a capacitor with the hot tip of the soldering iron.
- ② For flow soldering, consider the following conditions:
 - Do not dip the body of a capacitor into a solder bath. Expose only the terminals to the melt solder with the PC board interposing between the solder and the body of the capacitor. Solder only the reverse side of the PC board where the body of the capacitor is not located.

- Soldering conditions should be within the limits prescribed in the catalogs or product specifications.
 - Do not apply flux to any part of a capacitor other than the terminals.
 - Do not let any other component lean against nor come into contact with the capacitor while soldering.
- ③ For reflow soldering, consider the following conditions:
 - Soldering conditions (preheat, reflow temperature and time) should be within the limits prescribed in the catalogs or product specifications.
 - When using the infrared heater and setting its temperatures, adjust the heating levels taking into consideration that the color and materials of a capacitor vary in their infrared absorbance.
 - The allowable number of reflow passes is specified in the catalogs or product specifications.
 - When mounting a capacitor on the double-sided PC board, do not place any wiring pattern underneath the capacitor.
 - Avoid using Vapor Phase Soldering (VPS) system reflow.
 - ④ Do not try to reuse the capacitor that was removed from the PC board after soldering.
 - ⑤ Only use chip type capacitors for reflow soldering. The other type capacitors are not designed for the reflow.

3) Handling after soldering

After soldering the PC board, do not apply the following mechanical stress to the capacitor:

- ① Do not tilt, push down or twist the body of the capacitor.
- ② Do not grab the body of the capacitor to carry the assembly board.
- ③ Do not hit anything against the capacitor. When stacking the assembled boards, do not put any of the PC boards or other components against the capacitor.
- ④ Do not drop the assembled board.

4) Cleaning assembly boards

- ① Do not clean capacitors with the following cleaning agents:
 - Halogenated solvents: cause capacitor failures due to corrosion.
 - Alkali system solvents: corrode (dissolve) the aluminum can case.
 - Terpene and petroleum system solvents: deteriorate the rubber seal materials.
 - Xylene: deteriorates the rubber seal materials as well.
 - Acetone: erases the markings printed on a capacitor.
 Where cleaning is necessary, use only solvent resistant type capacitors that have been assured for the cleaning within the specific cleaning conditions prescriber in the catalogs or product specifications. In particular, carefully set up the conditions for ultrasonic cleaning system.
- ② Where cleaning the solvent resistance type of aluminum electrolytic capacitors, confirm the following conditions:
 - Control the contamination (the conductivity, pH, specific gravity, water content, etc.) of the cleaning agents.
 - After the cleaning, do not leave the capacitors (assembly boards) in an environment of cleaning agent-rich or in a closed container. Sufficiently evaporate the residual cleaning agent from the assembly boards and the capacitors by forced hot air at temperatures less than the upper limit of category temperature range for more than 10 minutes.
 In general, aluminum electrolytic capacitors are sensitive to contamination of halogen ions (particularly to chlorine ions). Depending on the properties of the electrolyte and rubber seal materials used in a capacitor, the halogen ions lead up to catastrophic failures on the capacitor. Where the inside of a capacitor has been contaminated with more than a certain amount of halogen ions and the capacitor is in use, the corrosion reaction of aluminum occurs. The corrosion causes the capacitor to have a significant increase in leakage current with heat produced, open the pressure relief vent and become open circuit mode failure. Due to global environmental issues (greenhouse effects and other environmental destruction by depletion of the ozone layer), the conventional cleaning solvents of CFC 113, Trichloroethylene and 1,1,1-trichloroethylene were replaced by substitutes. The following are some substitute cleaning agents and allowable cleaning conditions:

- a) Fatty-alcohol cleaning agents
 Pine Alpha ST-100S (Arakawa Chemical)
 Clean Through 750H, 750K, 750L and 710M (Kao)
 Technocare FRW-14, 15, 16 and 17 (Momentive Performance Materials)

[Cleaning conditions]

Either of immersion or ultrasonic cleaning, for a maximum of 10 minutes and at a maximum liquid temperature of 60°C is acceptable. Make sure that the markings on the capacitor are not rubbed against any other component or the PC board during cleaning. Note that shower cleaning affects the markings on the capacitor.

- b) HCFC (Freon 225) as Alternative CFCs
 AK225AES (Asahi Glass)

[Cleaning conditions]

Solvent resistant type capacitors, which were originally developed to intend to resist Freon TE or Freon TES, are also capable of withstanding any one of immersion, ultrasonic or vapor cleaning, for a maximum of 5 minutes (or 2 minutes for KRE and KRE-BP series capacitors or 3 minutes for SRM series). However, this type of cleaning agent is not recommended to use, as the cleaning materials may be banned in near future in view of global environmental issues.

- c) IPA (Isopropyl Alcohol)

Immersion cleaning with a maximum flux concentration of 2 wt% is acceptable.

5) Adhesives and coating materials

- ① Do not use any adhesive or coating materials containing halogenated solvents.
- ② Make sure of the following conditions before applying adhesive or coating materials to a capacitor,
 - No flux residue nor stain is left between the rubber seal of a capacitor and PC board.
 - Dry the capacitor to remove residual cleaning agents before applying adhesive and coating materials. Do not cover up the entire surface of the rubber seal of the capacitor with adhesives or coating materials.
 - Heating and curing conditions for adhesives and coating materials should be followed as prescribed in the catalogs or product specifications.
 - Covering up the entire surface of the rubber seal with resin mold materials will obstruct the normal diffusion of internal hydrogen gas from a capacitor and result in serious failures. Also, where the adhesive and coating materials contain a large amount of halogen ions, the halogen ions will contaminate the inside of the capacitor through the rubber seal materials, causing the capacitor to become a failure.
 - Depending on solvent materials that the adhesive or coating materials contains, note that the outer sleeve of a capacitor may lose a gloss or whiten in appearance.

6) Fumigation

In exporting or importing electronic devices, they may be exposed to fumigation with halide such as methyl bromide. Where aluminum electrolytic capacitors are exposed to halide such as methyl bromide, the capacitors will be damaged with the corrosion reaction with halogen ions in the same way as cleaning agents. For the export and import, Nippon Chemi-Con considers using some packaging method and so forth so that fumigation is not required. For customers to export or import electronic devices, semi-assembly products or capacitor components, confirm if they will be exposed to fumigation and also consider final condition of packaging. (Note that either cardboard or vinyl package has a risk of fumigation gas penetration.)

3) Precautions during operation of devices

- 1) Never touch the terminals of a capacitor directly with bare hands.
- 2) Do not short-circuit between the capacitor terminals with anything conductive.
 Also, do not spill any conductive liquid such as acid or alkaline solution over a capacitor.
- 3) Confirm environmental conditions where the device will be placed. Do not use the device in the following environmental conditions:
 - ① Water or oil spatters, or high condensation environment.
 - ② Direct sunlight.
 - ③ Ozone, ultraviolet rays or radiation.
 - ④ Toxic gases such as hydrogen sulfide, sulfuric acid, nitrous acid, chlorine and its compounds, bromine and its compounds and ammonium.
 - ⑤ Extreme vibration or mechanical shock that exceeds the limits in the catalogs or product specifications.

4) Maintenance inspections

- 1) For industrial use capacitors, make periodic inspections of the capacitors. Before the inspections, turn off the power supply of the device and discharge the electricity of the capacitors. Where checking it by a volt-ohm meter, confirm the polarity beforehand. Do not apply mechanical stress to the terminals of the capacitors during inspection.
- 2) Characteristics to be inspected
 - ① Significant damage in appearance: vent opening, electrolyte leakage, etc.
 - ② Electrical characteristics: leakage current, capacitance, $\tan \delta$ and other characteristics prescribed in the catalogs or product specifications

If finding anything abnormal on the characteristics above, check the specifications of the capacitor and take appropriate actions such as replacement.

5) Capacitor venting

- 1) A capacitor with more than a certain case size has the pressure relief vent functioning to escape abnormal gas pressure increase.
 If gas expels from a venting capacitor, disconnect the power supply of the device or unplug the power supply cord. If not disconnecting the power supply, the device circuit may be damaged due to the short circuit failure of the capacitor or short-circuited with the liquid that the gas was condensed to. It may cause secondary damages such as device burnout in the worst case scenario.
 The gas that comes out of the open vent is vaporized electrolyte, not smoke.
- 2) The gas expelled from a venting capacitor is more than 100°C. Never expose your face to the capacitor. If your eyes are exposed to the gas or you inhale it, immediately flush your eyes and/or gargle with water. If the electrolyte comes in contact with the skin, wash with soap and water.

6) Storage

- 1) Do not store capacitors at high temperature or high humidity. Store the capacitors indoors at temperatures of 5 to 35°C and humidities of less than 75%RH.
 In principle, aluminum electrolytic capacitors should be used within three years after production.
- 2) Keep capacitors packed in the original packaging material wherever possible.

- 3) Avoid the following storage environmental conditions:
- ① Water spattering, high temperatures, high humidity or condensation environment.
 - ② Oil spattering or oil mist filled.
 - ③ Salt water spattering or salt filled.
 - ④ Acidic toxic gases such as hydrogen sulfide, sulfuric acid, nitrous acid, chlorine, bromine and methyl bromide filled.
 - ⑤ Alkaline toxic gases such as ammonium filled.
 - ⑥ Acid or alkaline solutions spattering.
 - ⑦ Direct sunlight, ozone, ultraviolet rays or radiation.
 - ⑧ Extreme vibration or shock loading
- 4) JEDEC J-STD-020 (rev. C) is not applicable.

7 Capacitor disposal

Please consult with a local organization for the proper disposal of industrial waste. For incinerating capacitors, apply a high-temperature incineration (over 800°C). Incinerating them at temperatures lower than that may produce toxic gases such as chlorine. To prevent capacitors from explosion, punch holes in or sufficiently crush the can cases of the capacitors, then incinerate.

8 Catalogs

Specifications in the catalogs are subject to change without notice. Test data shown in the catalogs are not assured as the whole performance values, but typical values.

For more details, refer to JEITA/EIAJ RCR-2367C (March 2006) with the title of "Safety Application Guide for fixed aluminum electrolytic capacitors for use in electronic equipment".

9 Regarding compliance for EU REACH Regulation

- 1) According to the content of REACH handbook (Guidance on requirements for substances in articles which is published on May 2008), our electronic components are "articles without any intended release". Therefore they are not applicable for "Registration" for EU REACH Regulation Article 7 (1).
 Reference: Electrolytic Condenser Investigation Society
 "Study of REACH Regulation in EU about Electrolytic Capacitor"
 (publicized on 13 March 2008)
- 2) Nippon Chemi-Con develops the products without substance of very high concern(SVHC).DEHP(CASNo.117-81-7) was contained as some covering material, Nippon Chemi-Con abolished use of DEHP totally at June, 2011.